

RX9004 UHD HEVC Professional Decoder

Software Version 4.0.x

REFERENCE GUIDE



DRAFT B



ENGLISH (UK) - READ THIS FIRST!

If you do not understand the contents of this manual. **DO NOT OPERATE THIS EQUIPMENT.** Also, translation into any EC official language of this manual can be made available, at your cost.

ITALIANO - LEGGERE QUESTO AVVISO PER PRIMO!

Se non si capisce il contenuto del presente manuale. **NON UTILIZZARE L'APPARECCHIATURA.** È anche disponibile la versione italiana di questo manuale, ma il costo è a carico dell'utente.

SVENSKA - LÄS DETTA FÖRST!

Om Ni inte förstår informationen i denna handbok. **ARBETA DÅ INTE MED DENNA UTRUSTNING.** En översättning till detta språk av denna handbok kan också anskaffas, på Er bekostnad.

NEDERLANDS - LEES DIT EERST!

Als u de inhoud van deze handleiding niet begrijpt. **STEL DEZE APPARATUUR DAN NIET IN WERKING.** U kunt tevens, op eigen kosten, een vertaling van deze handleiding krijgen.

PORTUGUÊS - LEIA O TEXTO ABAIXO ANTES DE MAIS NADA!

Se não compreende o texto deste manual. **NÃO UTILIZE O EQUIPAMENTO.** O utilizador poderá também obter uma tradução do manual para o português à própria custa.

SUOMI - LUE ENNEN KÄYTTÖÄ!

Jos et ymmärrä käsikirjan sisältöä. **ÄLÄ KÄYTÄ LAITETTA.** Käsikirja voidaan myös suomentaa asiakkaan kustannuksella.

FRANÇAIS - AVANT TOUT, LISEZ CE QUI SUIV!

Si vous ne comprenez pas les instructions contenues dans ce manuel. **NE FAITES PAS FONCTIONNER CET APPAREIL.** En outre, nous pouvons vous proposer, à vos frais, une version française de ce manuel.

DANSK - LÆS DETTE FØRST!

Udstyret må ikke betjenes. **MEDMINDRE DE TIL FULDE FORSTÅR INDHOLDET AF DENNE HÅNDBOG.** Vi kan også for Deres regning levere en dansk oversættelse af denne håndbog.

DEUTSCH - LESEN SIE ZUERST DIESEN HINWEIS!

Sollte Ihnen der Inhalt dieses Handbuchs nicht klar verständlich sein, dann. **BEDIENEN SIE DIESE GERÄTE NICHT!** Eine Übersetzung des Handbuchs in diese Sprache ist gegen Berechnung lieferbar.

ΕΛΛΗΝΙΚΑ - ΔΙΑΒΑΣΤΕ ΠΡΩΤΑ ΑΥΤΟ!

Αν δεν καταλάβετε το περιεχόμενο αυτού του βοηθήματος/εγχειριδίου. **ΜΗΝ ΛΕΙΤΟΥΡΓΗΣΤΕ ΑΥΤΟΝ ΤΟΝ ΕΞΟΠΛΙΣΜΟ.** Επίσης, αυτό το εγχειρίδιο είναι διαθέσιμο σε μετάφραση σε αυτή τη γλώσσα και μπορείτε να το αγοράσετε.

ESPAÑOL - LEA ESTE AVISO PRIMERO!

Si no entiende el contenido de este manual. **NO OPERE ESTE EQUIPO.** Podemos asimismo suministrarle una traducción de este manual al (idioma) previo pago de una cantidad adicional que deberá abonar usted mismo.

Copyright

© Copyright Ericsson AB 2017. All rights reserved. No part of this document may be reproduced in any form without the written permission of the copyright owner.

Disclaimer

No part of this document may be reproduced in any form without the written permission of the copyright owner.

The contents of this document are subject to revision without notice due to continued progress in methodology, design and manufacturing. Ericsson shall have no liability for any error or damage of any kind resulting from the use of this document.

Contents

Chapter 1: Introduction

This chapter identifies the equipment versions covered by this Reference Guide, describes the purpose of the equipment in a typical system and lists the available options.

Chapter 2: Installing the Equipment

This chapter provides product specific installation information including rack mounting, ventilation and pin-out details of the external connectors.

Chapter 3: Getting Started

This chapter provides a guide to powering up the unit, setting up the IP address and using the unit.

Chapter 4: Front Panel Control

This chapter describes the front panel display menus and options and details any operating procedures.

Chapter 5: Web GUI Control

This chapter describes the configuration of the unit using the Web Graphical User Interface.

Chapter 6: Architecture and Networking

This chapter describes the principles and techniques used in the design of the equipment to aid in understanding its operation and function.

Chapter 7: Options, Licensing and Upgrades

This chapter provides details of option cards that may be fitted to this equipment.

Chapter 8: Preventive Maintenance and Fault-finding

This chapter details routine maintenance tasks, servicing advice and information regarding warranty and maintenance. It also lists error and error messages that may occur and recommends the action to be taken.

Annex A: Glossary

Annex B: Technical Specification

Annex C: Compliance

Annex D: Replace Source Automation

Annex E: Network Configuration

Annex F: Aspect Ratio Adaption

Introduction

Ericsson's Encoder-Decoder product line is ideal for point-to-point video distribution. Offering professional quality and proven reliability Ericsson's RX9004 Ultra-High Definition (UHD) High Efficiency Video Encoding (HEVC) Professional Decoder is the perfect solution for content gathering, head-end feeds, confidence feeds with the flexibility to deliver high quality video anywhere you need. Content distributors, aggregators, broadcasters and operators can capture, contribute and distribute live video content with confidence and efficiency.

Ericsson's RX9004 UHD (4k) HEVC Professional Decoder is a new decoder platform specifically designed to meet the needs of the contribution market for efficient point-to-point video delivery over IP & ASI networks. It can ingest one independent channel in HEVC 4k and deliver SD or HD 4:2:2 uncompressed outputs.

A web-based management and configuration interface provides full control of the operating needs.

This Reference Guide should be kept in a safe place for reference for the life of the equipment. It is not intended that this Reference Guide will be amended by the issue of individual pages. Any revision will be by a complete reissue. Further copies of this Reference Guide can be ordered from the address listed in *Customer Services*. If passing the equipment to a third party, also pass the relevant documentation.

Revision History

Issues of this Reference Guide are listed below:

Issue	Date	Software Version	Comments
A	Jan 2017	4.0.x	Initial release of the RX9004 UHD HEVC Professional Decoder Reference Guide.

Associated Documents

The following manuals/guides are also associated with this equipment:

Ericsson Document Identity	Title
1/1553-FGB 101 752	Video Processing/Stream Processing Products – Generic Product Information - Quick Guide
174 02-FGB 101 348	Installation, Safety and Compliance Information Generic Product Information - Reference Guide

Useful Links:

Installation, Safety and Compliance Information – Generic Product Information - Reference Guide can be viewed at:

<http://archive.ericsson.net/service/internet/picov/get?DocNo=17402-FGB101348&Lang=EN&HighestFree=Y>

Product Guide downloads are available for all Product Families:

<http://www.ericsson.com/ourportfolio/products/television-and-video>

Trademarks

All best endeavors have been made to acknowledge registered trademarks and trademarks used throughout this Reference Guide. Any notified omissions will be rectified in the next issue of this Reference Guide. Some trademarks may be registered in some jurisdictions but not in others.

Registered trademarks and trademarks used are acknowledged below and marked with their respective symbols. However, they are not marked within the text of this Reference Guide.

Registered Trademarks

Dolby® Registered trademark of Dolby Laboratories Licensing Corporation.

GuideBuilder® Registered trademark of Triveni Digital Inc.

Trademarks

Reflex™ Trademark of Ericsson Television.

Warnings, Cautions and Notes

Heed Warnings

All warnings on the product and in the operating instructions should be adhered to. The manufacturer can not be held responsible for injuries or damage where warnings and cautions have been ignored or taken lightly.

Read Instructions

All the safety and operating instructions should be read before this product is operated.

Follow Instructions

All operating and use instructions should be followed.

Retain Instructions

The safety and operating instructions should be retained for future reference.



Warning!

Warnings give information which, if strictly observed, will prevent personal injury or death, or damage to property or the environment. They are highlighted for emphasis, as in this example, and are placed immediately preceding the point at which the reader requires them.



Caution!

Cautions give information which, if strictly followed, will prevent damage to equipment or other goods. They are highlighted for emphasis, as in this example, and are placed immediately preceding the point at which the reader requires them.

Note: Notes provide supplementary information. They are highlighted for emphasis, as in this example, and are placed immediately after the relevant text.

EMC Compliance

This equipment is certified to the EMC requirements detailed in the *Installation, Safety and Compliance Information for Ericsson Compression Products Reference Guide* supplied with your product. To maintain this certification, only use the leads supplied or if in doubt contact Customer Services.

Contact Information

Support Services

Ericsson understands that our products are “mission-critical”, providing services that influence customer perception and impact your revenue. Our objective is to ensure that you realize maximum utility and achieve the highest levels of availability from our products. To realize that objective, we offer a variety of Service Level Agreements designed to meet your business needs and budget.

Warranty

All Ericsson products and systems are designed and built to the highest standards and are covered under a comprehensive 12-month warranty.

Service Level Agreements

Customers may choose one of several Support packages, either as an enhancement during the standard 12-month warranty or as an extension after the warranty has expired.

For standalone equipment, customers may choose either Ericsson's **Extended Hardware Warranty** or **Secure Basic Support**. Extended Hardware Warranty provides hardware repair of covered equipment after the expiration of the standard warranty. Secure Basic Support provides hardware repair, remote diagnostics and support, and 24x7x365 remote support for emergencies.

For systems, along with Secure Basic Support, customers have the option of either **Secure Advanced Support** or **Secure Superior Support**. These support packages provide higher committed response and resolution times, onsite support where necessary, service performance review and a host of other proactive services to help you get the maximum return on your investment in Ericsson solutions.

Call Ericsson Sales for more details.

Customer Services

Europe, Middle East and Africa	Tel: +44 (0) 23 8048 4455 Fax: +44 (0) 23 8048 4467 Email: tvsupportemea@ericsson.com	
Americas	Tel: +1 888 671 1268 Tel: +1 678 812 6255 Fax: +1 678 812 6263 Email: tvsupportamericas@ericsson.com	US and Canada International
Asia	Tel: +852 2590 3820 Fax: +852 2590 9550 Email: tvsupportapac@ericsson.com	Hong Kong Hong Kong
Australia and New Zealand	Tel: +61 (0) 2 9111 4080 Fax: +61 (0) 2 9111 4949 Email: tvsupportanz@ericsson.com	
Internet Address	www.ericsson.com	

Technical Training

Ericsson provides a wide range of training courses on the operation and maintenance of our products and on their supporting technologies. Ericsson can provide both regularly scheduled courses and training tailored to individual needs. Courses can be run either at your premises or at one of our dedicated training facilities.

International	Tel: +44 (0) 23 8048 4229 Fax: +44 (0) 23 8048 4161 Email: tvglobaltraining@ericsson.com
----------------------	--

Customer Services and Technical Training Postal Address

Ericsson
Unit 2
Strategic Park
Comines Way
Hedge End
Southampton
Hampshire
SO30 4DA
United Kingdom

Return of Equipment

If you need to return equipment for repair please contact your local Ericsson Customer Services Department.
Please refer to the Customer Services Contact Information on Page vii.

You will then be directed to return the faulty equipment to a repair centre with the appropriate facilities for that equipment. A tracking number will be issued that should be used if you need to enquire about the progress of the repair. The equipment should be properly packed and the tracking number should be clearly marked on the outside of the packaging.

Technical Publications

If you need to contact Ericsson Technical Publications regarding this publication, e-mail: tvtechpubs@ericsson.com.



Introduction

Chapter 1

Contents

1.1	Introduction	1-3
1.1.1	Who Should Use this Reference Guide	1-3
1.1.2	Software Version	1-3
1.1.3	New Features in this Release	1-3
1.1.4	What Equipment is Covered by this Reference Guide	1-4
1.2	RX9004 Overview	1-5
1.2.1	Inputs	1-5
1.2.2	Decoding	1-5
1.2.3	Outputs	1-6
1.2.4	User Interface	1-6
1.3	Front Panel	1-7
1.3.1	Liquid Crystal Display (LCD)	1-7
1.3.2	Keypad	1-7
1.3.3	Status LEDs	1-8
1.4	Rear Panel	1-9
1.4.1	Base Chassis Connectors	1-9
1.4.2	Option Card Connectors	1-9
1.5	License Keys	1-10

List of Figures

Figure 1.1	RX9004 Overview	1-5
Figure 1.2	Front Panel	1-7
Figure 1.3	Front Panel Display	1-7
Figure 1.4	Front Panel Keypad	1-8
Figure 1.5	Front Panel Status LEDs	1-8
Figure 1.6	Rear Panel	1-9

List of Tables

Table 1.1	RX9004 Base Chassis Options	1-4
Table 1.2	RX9004 Software Options	1-4
Table 1.3	Front Panel Buttons	1-8



BLANK

1.1 Introduction

1.1.1 Who Should Use this Reference Guide

This Reference Guide is written for operators / users of the RX9004 UHD HEVC Professional Decoder. It describes the unit's functions and operation. The Reference Guide is written to assist in the installation and day-to-day operation and care of the unit. Maintenance information requiring the covers to be removed is not included.



Warning!

Do not remove the top cover of this equipment. Hazardous voltages are present within this equipment and may be exposed if the top cover is removed. Only Ericsson television trained and approved service engineers are permitted to service this equipment.



Caution!

Unauthorized maintenance or the use of non-approved replacements may affect the equipment specification and invalidate any warranties.

1.1.2 Software Version

This Reference Guide covers the functions of software versions **4.0.x** and later.

To verify the installed version either:

- Access the front panel, see Chapter 4, Front Panel Control.
- Access the Web Browser screens, see *Chapter 5, Web GUI Control*.

This manual continues to be relevant to subsequent build versions where the functionality of the equipment has not changed. Where the build standard changes the functionality, a new issue of this manual will be provided. The appropriate number should be quoted in all correspondence with Ericsson.

1.1.3 New Features in this Release

The 4.0.x release of software supports the following features:

- ASI or IP input.
- 4 x 3G SDI outputs.
- Supports HD or UHD video.

- HEVC Main, Main 10, Main 4:2:2 10 Level 5.1.
- Audio codecs:
 - 4x Stereo pairs of LPCM audio pass-through.
 - 4x Dolby E streams.
 - 4x Stereo pairs of MPEG-1 Layer II.
 - 4x Dolby Digital 2.0 decode.
 - 1x Dolby Digital 5.1 decode.
- Front Panel control.
- Web-based Graphical User Interface (GUI).
- Dual power supplies.

1.1.4 What Equipment is Covered by this Reference Guide

This Reference Guide covers the RX9004 main units and options. The base chassis options available for the RX9004 are described in the following table.

Table 1.1 RX9004 Base Chassis Options

Marketing Code	Price Object Number	Supply Object Number	Description

The functionality of the RX9004 can be augmented by purchasing software licensing keys (software options). These are listed in the following table.

Table 1.2 RX9004 Software Options

Marketing Code	Price Object Number	Supply Object Number	Description

1.2 RX9004 Overview

RX9004 comes in a 1RU form factor and accepts compressed input through Ethernet (or ASI). By decoding 4k HEVC content it provides (in combination with E111 4k HEVC Encoder) an end-to-end 4k contribution solution.

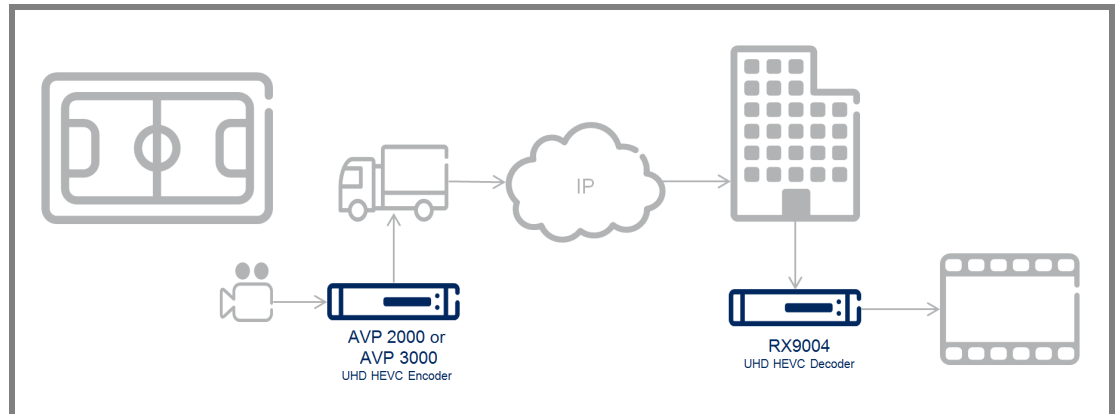

Figure 1.1 RX9004 Overview

RX9004 is sold as a turn-key appliance and no software installation is needed. The product has an LCD front panel interface and can be managed remotely (including firmware updates).

1.2.1 Inputs

RX9004 accepts compressed video/audio inputs over Ethernet connection:

- Compressed a/v input over ASI (EN50083) and Ethernet interfaces IP based Transport Stream.
- All ASI ports use BNC 75 Ω connectors.
- Single Program and Multi-Program TS inputs.
- CBR inputs.
- Source Specific Multicast (SSM) is also supported for TS inputs.
- Ethernet source, (UDP/IP and UDP/RTP/IP) unicast or multicast input is supported.
- Audio codecs supported for Live input are MPEG-1 Layer I & II and AC-3 (Dolby Digital and Dolby Digital Plus, 5.1 and Stereo), passthrough of linear and Dolby E.

1.2.2 Decoding

RX9004 supports a 4k HEVC decode to allow for high quality contribution application and covers the full range of contribution delivery requirements.

1.2.3 Outputs

Outputs are variants of the same input/source content that target a specific contribution or distribution use case. Multiple outputs can be generated from the same source feed/channel and each can have its own characteristics in terms of post-processing and delivery options.

The RX9004 can output uncompressed decoded video on its video output connectivity.

The following output options are available:

- Quad 3G-SDI (Level A, B) (for UHD outputs only, depending upon configuration).
- HDMI 2.0 (for UHD outputs only, depending upon configuration).

1.2.4 User Interface

RX9004 can be managed as a stand-alone appliance using its Web GUI. Additionally, detailed information regarding the status of each service is available through. RX9004 provides an extensive and intuitive interface for:

- Appliance setup.
- Profile management.
- Service monitoring and control.
- Firmware upgrade.

The list below highlights the most important features:

- Continuous monitoring of I/O streams (bit rate, fps, packet loss, etc.) Monitoring enhancements:
 - Web-based, AJAX enhanced UI for real-time monitoring and control.
 - Multi-user support, including LDAP integration.
 - Auto-sense input loss.
- Edit profiles while in use.
- SNMP monitoring/reporting/alarming.
- Advanced network configuration (VLAN, etc.).

1.3 Front Panel

The front panel provides various controls and displays for configuring and monitoring the unit.

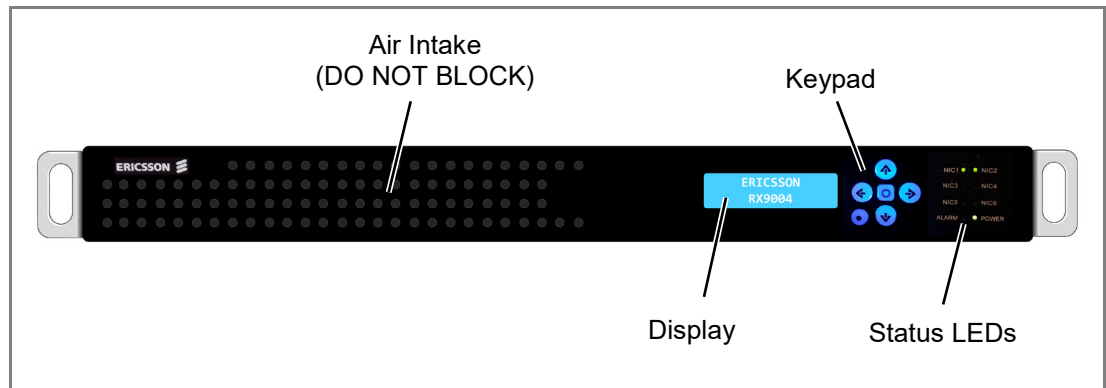

Figure 1.2 Front Panel

1.3.1 Liquid Crystal Display (LCD)

This 16 character, 2-line display screen enables configuration of the unit by selecting various pages, fields and parameters (using the Keypad). On boot-up, the display shows the unit type/model.



Figure 1.3 Front Panel Display

For a description of the all the pages and parameters, see *Chapter 4, Front Panel*.

1.3.2 Keypad



The keypad provides various buttons for powering-up/shutting-down the unit, and for navigating the configuration screens.



Figure 1.4 Front Panel Keypad

The keypad functions are explained in the table below.

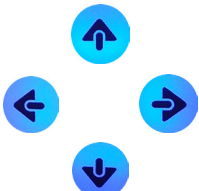
Table 1.3 Front Panel Buttons

Key	Description
	<p>Navigation - The arrow keys enable you to move (up, down, left and right) within the confirmation pages, select parameters and increment or decrement their values (where applicable).</p>
	<p>Power-up - This key powers-up the unit, when pressed and held for 2 seconds. The unit will show an initial display screen showing the IP addresses for NIC1 and NIC2.</p> <p>Select – When the unit is powered up and in configuration mode, this key enables you to select the displayed submenu or displayed parameter.</p>
	<p>Configuration Mode Select – This key, when pressed, enables you to enter the configuration menu from the initial display screen.</p> <p>Shut-down – This key also shuts down the unit, when pressed and held for more than 5 seconds.</p>

1.3.3 Status LEDs

Eight LEDs display the activity on the network interfaces (NIC1 to NIC6) (NIC3 to NIC6 are not used?) and display ALARM and POWER status. (Flashing, colours or just green on/off?)

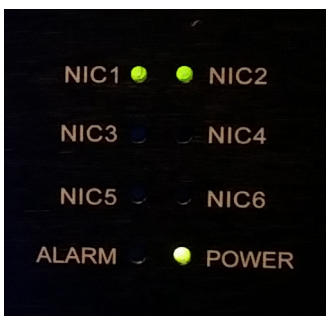

Figure 1.5 Front Panel Status LEDs

1.4 Rear Panel

The Rear Panel provides access to power and signal connectors. BNC connectors and Ethernet network ports are numbered as shown in the figure below (new figure required? This one is from Ericsson's datasheet and is available on the website? LAN3/4 and ASI)

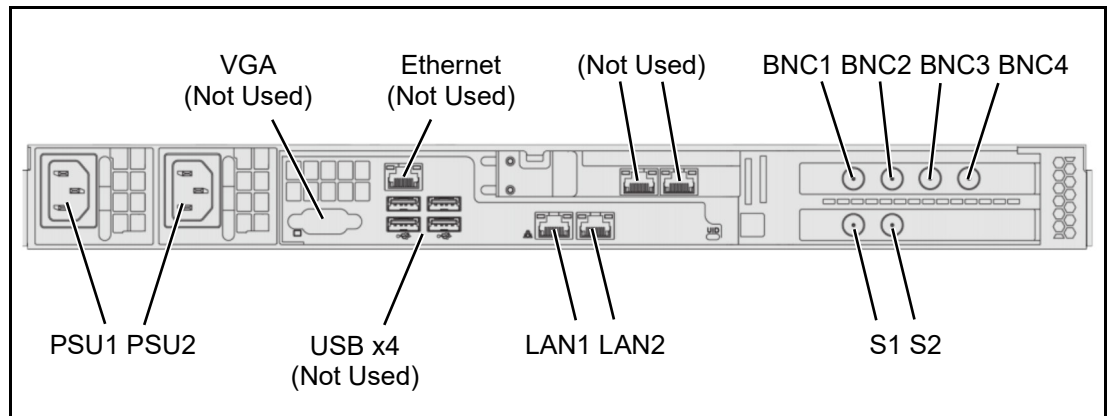

Figure 1.6 Rear Panel

For a full description of all the connectors, see *Chapter 2, Installing the Equipment*.

1.4.1 Base Chassis Connectors

The following connectors are provided on the base chassis:

- **PSU 1&2** – Dual IEC power supply connectors are provided as standard for 110 VAC / 240 VAC supply.
- **VGA** – Standard VGA connector (not used).
- **USB x4** – Four USB (2) connectors (not used).
- **Ethernet** – An Ethernet connector (not used).
- **LAN1/2** – These Ethernet connectors correspond to Network Interface Connections NIC1/2 (NIC3/4/5/6 are not used).

1.4.2 Option Card Connectors

The following connectors are provided on the ASI Input Card:

- **S1-2** – Two software configurable BNC inputs/output ports are capable of DVB-ASI.
- **G** – Genlock input to enable a reference signal from a signal generator to be used to synchronize television picture sources together.

The following connectors are provided on the **DTA2174** Option Card (**name change?**):

- **S1-4** – Four software configurable BNC input/output ports are capable of 3G-SDI to carry 4k video.
- **G** – Genlock input to enable a reference signal from a signal generator to be used to synchronize television picture sources together.

1.5 License Keys

Licenses control the availability of some of the features accessible from the unit.

A License Key consists of a feature, and the number of instances of this feature that are allowed within the chassis or option card.

License Keys are allocated on a 'first configured first served' basis within the chassis. If an attempt is made to enable a feature, but the required license key is not available then the feature is not enabled, and a log message is generated.

When a function that has a license associated with it is disabled, the license key is released within 1 second, and thereafter available to be re-allocated.

See *Chapter 7, Options, Licensing and Upgrades* for details of how to install firmware and licenses.



Installing the Equipment

Chapter 2

Contents

2.1	Read This First!	2-3
2.2	Unpacking	2-3
2.3	Mounting and Ventilation	2-3
2.3.1	Fixing and Rack Mounting	2-3
2.3.2	Ventilation	2-4
2.4	Power Connectors	2-5
2.4.1	PSU Connectors.....	2-5
2.4.2	Earthing Connector.....	2-6
2.5	Signal Connectors	2-6
2.5.1	LAN Connectors	2-6
2.5.2	DCA 2154 Option Card Connectors.....	2-7
2.5.3	DCA 2174 Option Card Connectors.....	2-8

List of Figures

Figure 2.1	Rails (Looking at the Left Side of the Chassis, Facing Right).....	2-3
Figure 2.2	Adjusting the Rack Rails (Square vs. Round)	2-4
Figure 2.3	Airflow through the Equipment.....	2-5
Figure 2.4	Power Connectors	2-5
Figure 2.5	Earthing Connector.....	2-6
Figure 2.6	DCA 2154 Option Card.....	2-7
Figure 2.7	DCA 2174 Option Card.....	2-8

List of Tables

Table 2.1	PSU Connectors.....	2-5
Table 2.2	LAN Connectors	2-6
Table 2.3	DCA 2154 Option Card Connectors.....	2-7
Table 2.4	DCA 2174 Option Card Connectors.....	2-8



BLANK

2.1 Read This First!

Please refer to *Annex C, Compliance* for full details of installation requirements. This guide only contains additional product specific information where required.

2.2 Unpacking

Inspect the packing box the equipment was shipped in and note if it was damaged in any way. If the equipment itself shows damage you should file a damage claim with the carrier who delivered it.

Decide on a suitable location for the rack unit that will hold the equipment. It should be situated in a clean, dust-free area that is well ventilated. Avoid areas where heat, electrical noise and electromagnetic fields are generated. You will also need it placed near a grounded power outlet.

2.3 Mounting and Ventilation

2.3.1 Fixing and Rack Mounting

The equipment is designed for fixed use only and has been shipped with fixing brackets suitable for a standard 19-inch rack. When installed in a rack, it should be secured using the fixing brackets. In addition, support shelves must be used to reduce the weight on the brackets. Ensure it is firmly and safely located and it has an adequate free-flow of air.

A freestanding unit should be installed on a secure horizontal surface where it is unlikely to be knocked or its connectors and leads disturbed.

To install the equipment:

1. Unpack the chassis out of the shipment box and the protective bag.
2. Use the schematic to assemble and attach the rack rails to the chassis and the rack.

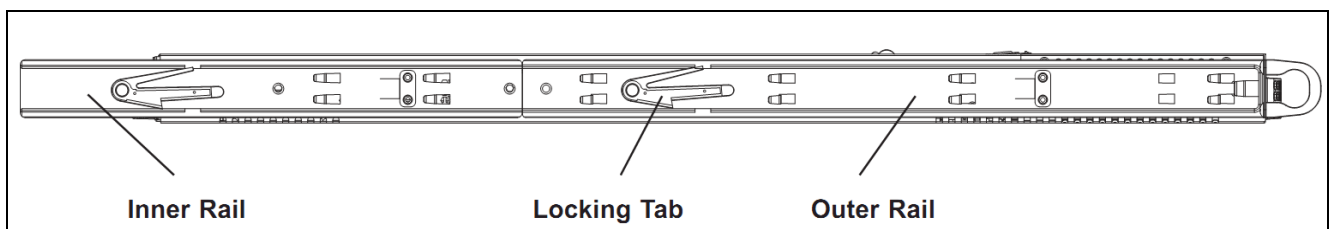

Figure 2.1 Rails (Looking at the Left Side of the Chassis, Facing Right)

- a The chassis comes with the Outer Rails pre-installed. Attach the Inner Rails (one in each side of the chassis) and secure them with 2 screws.
- b Assemble the Rack Rails (2 pieces from each side, refer to labels on the rails) and attach them to the rack. Various types of rack mounting

mechanisms can be accommodated, refer to the diagram below on how to adjust the Rack Rails according to the mounting type of your rack.

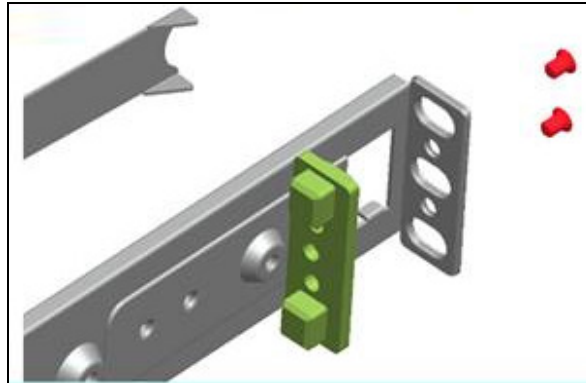

Figure 2.2 Adjusting the Rack Rails (Square vs. Round)

- c Line up chassis rails with the front of the rack rails and slide the chassis rails into the rack rails, keeping the pressure even on both sides (you may have to depress the locking tabs when inserting). When the server has been pushed completely into the rack, you should hear the locking tabs "click".
 - d Insert and tightening the front screws that hold the front of the server to the rack.
 - e Both chassis rails have a locking tab, which serves two functions. The first is to lock the server into place when installed and pushed fully into the rack, which is its normal position. Secondly, these tabs also lock the server in place when fully extended from the rack. This prevents the server from coming completely out of the rack when you pull it out for servicing.
3. Remove any protective film from the front panel or the chassis.
 4. Ensure that all air-holes in the front and rear are not blocked.
 5. Insert the power plug(s) on the back of the unit.

2.3.2 Ventilation

A front grille and front-mounted cooling fans are provided for ventilation of the unit. They ensure reliable operation of the product and protect it from overheating. The openings of the fans must not be blocked or covered.

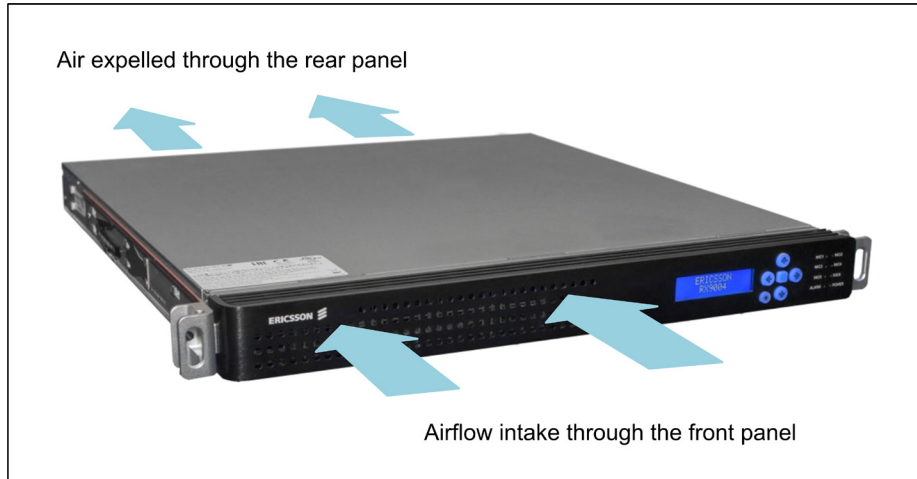

Figure 2.3 Airflow through the Equipment

2.4 Power Connectors

2.4.1 PSU Connectors

The unit has two AC power supply connectors to enable auto-switching and ensure unit operation in the event of a failure of one of the supplies. The connectors provide AC: 90-264V / 47- 63Hz, 1400W.

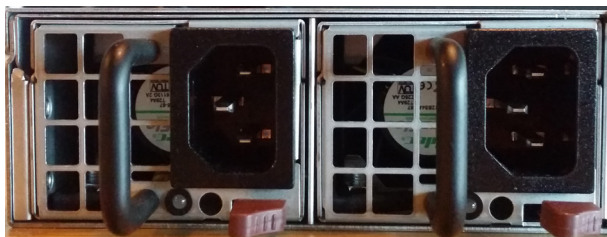

Figure 2.4 Power Connectors

Table 2.1 PSU Connectors

Item	Specification
Connector type	IEC
Connector designation	PSU1, PSU2
Pin outs	L (Live) E (Earth) N (Neutral)

2.4.2 Earthing Connector



Caution!

It is strongly recommended that the earthing terminal at the rear panel of the equipment is connected to a site Technical Earth before any external connections are made and the equipment is powered. This limits the migration of stray charges.

The earthing connector is located to the left of the Option Cards.



Figure 2.5 Earthing Connector

2.5 Signal Connectors

Signal connections are made via the rear panel. The rear panels, which are available are shown below. Full technical specifications for the connections are given in *Annex B*.

2.5.1 LAN Connectors

The unit has four Local Area Network (LAN) ports. The ports are accessible via RJ-45 connectors on the rear panel of the chassis.

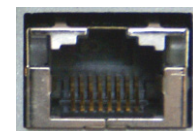

Table 2.2 LAN Connectors

Item	Specification
Connector type	RJ-45 (100/1000 Base T)
Connector designation	LAN1, LAN2
Pin outs (Unused pins are not connected)	Pin 1 - Tx Out (+) Pin 2 - Tx Out (-) Pin 3 - Rx In (+) Pin 6 - Rx In (-)

Each Ethernet Data Port has a rear panel mounted status LED associated with it to indicate link status, activity and speed.

2.5.2 DCA 2154 Option Card Connectors

The DCA 2154 Option Card (name change? Card not supported?) rear panel provides four configurable HD-SDI/SD-SDI or DVB-ASI input/output ports, and one genlock input for connection to an external reference.



Figure 2.6 DCA 2154 Option Card

Table 2.3 DCA 2154 Option Card Connectors

Item		Specification
Connector types		75 Ω female BNC 1.0/2.3 DIN
Connector designation		1, 2, 3, 4, G
Pin-outs	Centre	Input
	Shield	Ground/Chassis

2.5.3 DCA 2174 Option Card Connectors

The DCA 2174 Option Card (name change?) rear panel provides four configurable 3G-SDI/HD-SDI, SD-SDI or DVB-ASI input/output ports, and one genlock input for connection to an external reference.



Figure 2.7 DCA 2174 Option Card

Table 2.4 DCA 2174 Option Card Connectors

Item		Specification
Connector types		75 Ω female BNC 1.0/2.3 DIN
Connector designation		1, 2, 3, 4, G
Pin-outs	Centre	Input
	Shield	Ground/Chassis



Getting Started

Chapter 3

Contents

3.1	Introduction	3-3
3.2	How to Connect Up the Unit	3-3
3.3	How to Power Up the Unit	3-4
3.4	How to Set Up the Network IP Address(es)	3-4
3.5	How to Use the Web GUI	3-6
3.6	How to Configure Your Device Using the Web GUI	3-6
3.7	How to Power Down the Unit	3-8
3.7.1	Powering Down Using the Front Panel	3-8
3.7.2	Powering Down Using the Web GUI	3-8

List of Figures

Figure 3.1	RX9004 Connections	3-3
Figure 3.2	Login Page	3-6
Figure 3.3	CONFIGURE Page	3-7

List of Tables

Table 3.1	IP Address Restrictions	3-5
-----------	-------------------------------	-----

BLANK

3.1 Introduction

Due to the number of different ways the RX9004 can be used, it is impossible to give precise setting up instructions for every possible working scenario. This chapter, therefore, gives general guidance and principles on how to power up and set up your unit for operation and describes the more common operations you will want to perform.

For details of all Front Panel menus and controls, see *Chapter 4, Front Panel Control*. For details of all Web Graphical User Interface (GUI) menus and controls, see *Chapter 5, Web GUI Control*.

3.2 How to Connect Up the Unit

See *Chapter 2, Installing the Equipment* for all connector details.

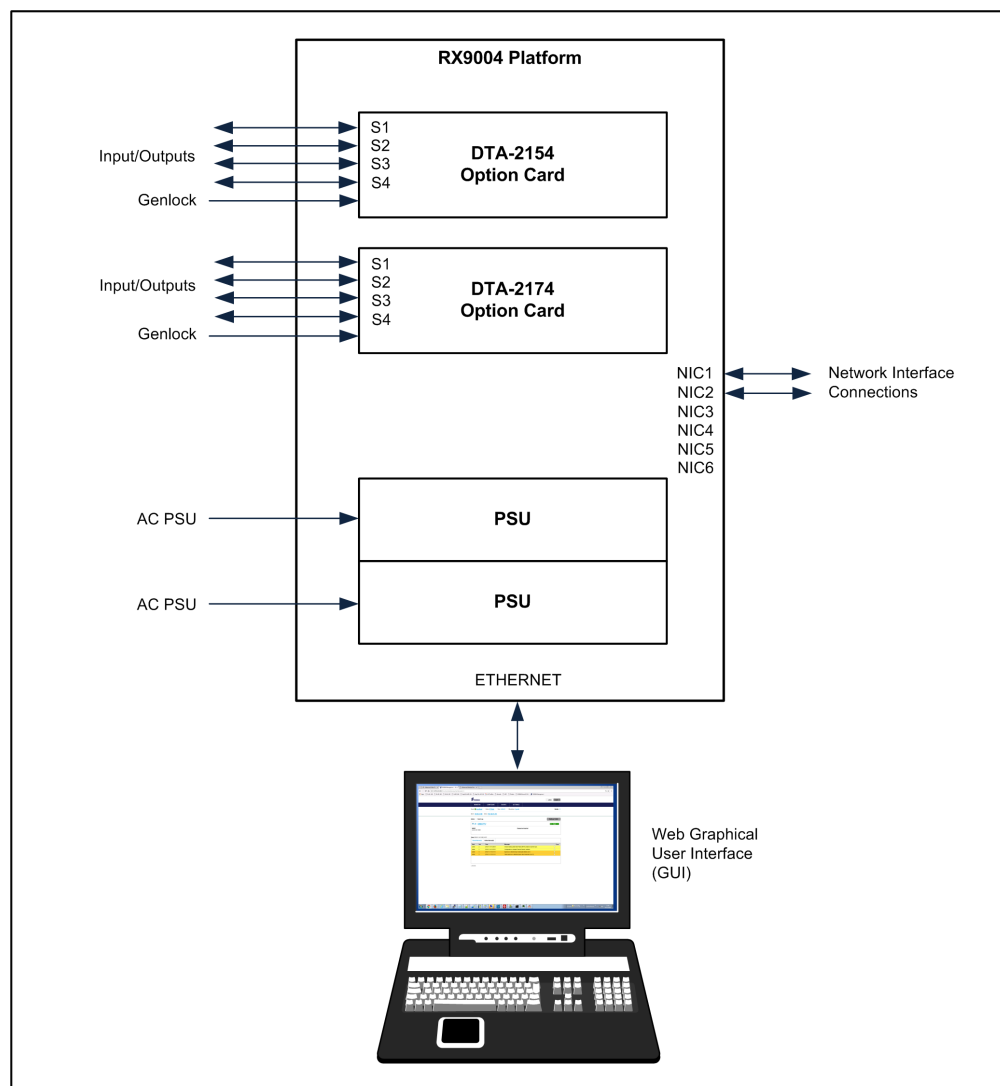



Figure 3.1 RX9004 Connections

To connect up the unit(s):

1. Connect Option Card signal BNC connectors, as required, for your input Transport Streams.
2. Connect output network interface connectors NIC1 to NIC6, as required, for your output Transport Streams.
3. Connect computer control connectors Ethernet for Web GUI Control to your local area network.
4. Connect dual AC power connectors to the power supply.

3.3 How to Power Up the Unit

To power up the unit(s):

1. With all signal and power cables connected as required, switch on the AC power supplies to the unit.
2. At the Front Panel, press and hold the  button for 2 seconds to turn on the unit
3. Wait for unit initialisation to complete (approximately 1.5 minutes, depending on the number of options fitted in the unit). When the unit is booted-up, by default, the display will show the currently assigned IP address(es) for the first 2 network interfaces (NIC1 and NIC2). All appliances are configured for DHCP as factory default.



3.4 How to Set Up the Network IP Address(es)



Each unit is shipped with DHCP-enabled network configuration. Once fully operational, the unit will display the configured IP address(es) on its Front Panel display.

Dynamic Host Configuration Protocol (DHCP) is a client/server protocol that automatically provides an Internet Protocol (IP) host with its IP address and other related configuration information such as the subnet mask and default gateway.

Changing the network IP address(es) is accomplished using the Front Panel menus. For a full description of these menus, see *Chapter 4, Front Panel Control*.

To set the IP address(es):

1. Ensure the unit is fully powered up.
2. On the Front Panel, press the  button to enter the configuration menu.
3. Using the arrow keys, navigate to the **Network** option and click the  button to select it.

4. Modify the **DHCP**, **IP**, **Netmask**, **Gateway** and **MAC** settings, as required, for NIC1-6.
5. Press the  (Select) button to save or  (Cancel) to discard the changes.

Note: It may be necessary to set the subnet mask to 0 in order to allow the IP address to be changed. Configuring a single NIC is sufficient for operation of the unit.

IP Addresses on the unit must adhere to RFC3330 range of restrictions as listed in the following table of allocated IP addresses.

Table 3.1 IP Address Restrictions

Block	Present Use	Reference
0.0.0.0/8	This Network	[RFC1700, p4]
10.0.0.0/8	Private-Use Networks	[RFC1918]
14.0.0.0/8	Public-Data Networks	[RFC1700, p181]
24.0.0.0/8	Cable Television Networks	---
39.0.0.0/8	Reserved but subject to allocation	[RFC1797]
127.0.0.0/8	Loopback	[RFC1700, p5]
128.0.0.0/16	Reserved but subject to allocation	---
169.254.0.0/16	Link Local	---
172.16.0.0/12	Private-Use Networks	[RFC1918]
191.255.0.0/16	Reserved but subject to allocation	---
192.0.0.0/24	Reserved but subject to allocation	---
192.0.2.0/24	Test-Net	---
192.88.99.0/24	6to4 Relay Anycast	[RFC3068]
192.168.0.0/16	Private-Use Networks	[RFC1918]
198.18.0.0/15	Network Interconnect Unit Benchmark Testing	[RFC2544]
223.255.255.0/24	Reserved but subject to allocation	---
224.0.0.0/4	Multicast	[RFC3171]
240.0.0.0/4	Reserved for Future Use	[RFC1700, p4]

Note: The control network and data networks should not conflict. It is suggested that the ranges for these networks are in the Private-Use Networks as listed in the summary Table. IP Address range 192.168.10.x (subnet 255.255.255.0) is used for internal unit communications, so should not be used for external communications.

3.5 How to Use the Web GUI

When the correct IP addresses are shown on the Front Panel display, proceed to connect to the Web Graphical User Interface (GUI) in order to configure the network parameters further and/or setup additional network interfaces and VLANs.

To configure the unit using the web GUI:

1. Ensure the network parameters have been set up. See the previous section in order to configure the network parameters of the unit.
2. Point your internet browser to the first IP address shown on the Front Panel (e.g. <http://10.0.1.2>) or any other configured IP address that is accessible from your network location/subnet. The login page appears, as shown below (**new image required**).

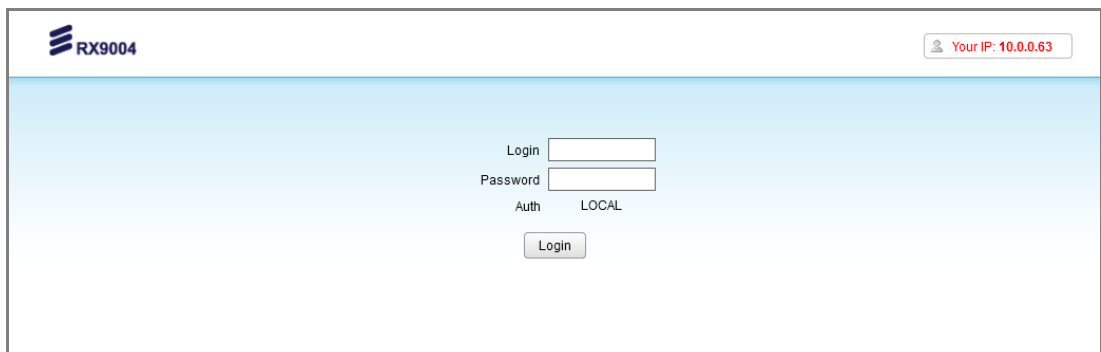

Figure 3.2 Login Page

3. Enter your **Login** name and **Password**. The default credentials for accessing the Web GUI are Login username: **admin**, and Password: **admin4Hms**.
4. Once logged in, the **MONITOR** screen displays all units that have already been configured. You can now configure your unit using the menu options displayed.

For a description and details of all the GUI screens and options, see *Chapter 5, Web GUI Control*. For details of supported web browsers please refer to the release notes accompanying the latest software release.

3.6 How to Configure Your Device Using the Web GUI

The RX9004's hierarchical configuration is structured to enable its function to be adapted for use to a wide range of applications.

A diagram of **Configuration Hierarchy** is provided at the top-level page when the **CONFIGURE** menu tab is selected.

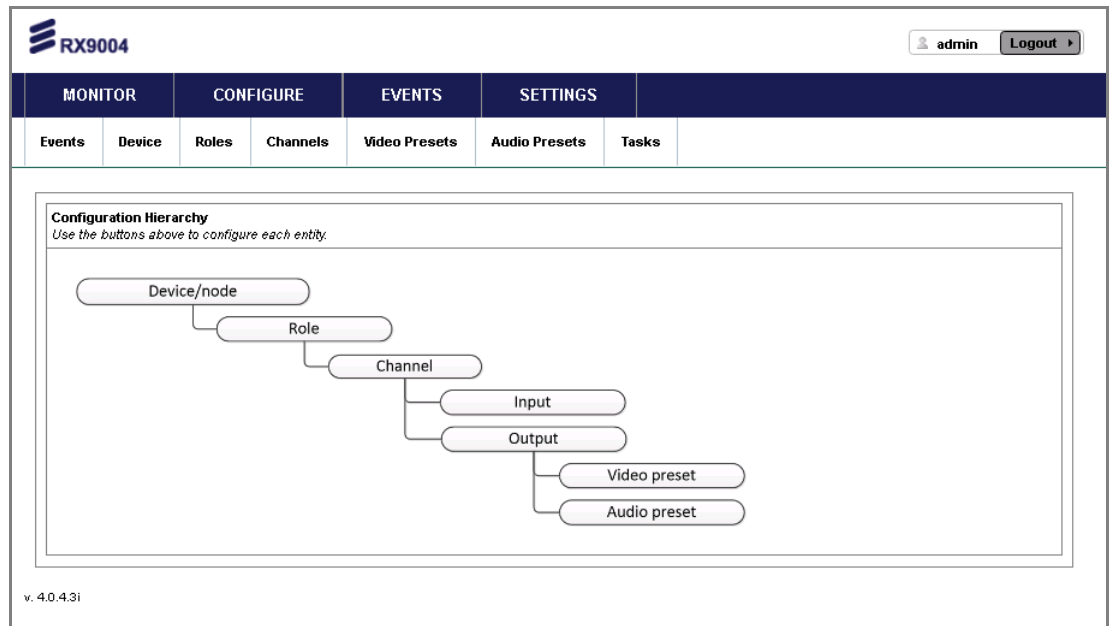

Figure 3.3 CONFIGURE Page

Device/Node

The “Device/Node” is another name for the RX9004 unit and enables the usage of the RX9004 unit to be specified.

Role

A “Role” is a collection of channels. Roles are particularly useful when multiple devices are used within a decoding system and are assigned to RX9004 devices to deliver the associated channels/outputs. A Role can therefore be assigned to several units at the same time, but a single unit can only have one Role at any given time.

Channel

A “Channel” is a processing task with a single input source and one output streams. Each output uses a video and an audio preset. Multiple Channels can use the same audio and/or video presets and any change to those presets (e.g. bit-rate) affects all associated channels automatically.

Input

The “Input” source is specified by the Channel. Either an UDP/IP or ASI source may be selected as the source from which the video and audio may be decoded, processed and output.

Output

The “Output” comprises the decoded and processed input sources with pre-configured video and audio settings.

Video Preset

A “Video Preset” enables a collection of video decoding parameters to be configured, named and applied to channel outputs.

Audio Preset

A “Audio Preset” enables a collection of audio decoding parameters to be configured, named and applied to channel outputs.

For further details on configuring these items, see *Chapter 5, Web GUI Control*.

3.7 How to Power Down the Unit



The unit can be powered down from the Front Panel or from the Web GUI.

3.7.1 Powering Down Using the Front Panel

To power down the unit:

1. On the Front Panel, press and hold the  button for **more than 5 seconds**. This will power down the unit.

or

1. Go to the Configuration menu by pressing the  button.
2. Using the arrow keys, navigate to the **Power Off** menu and press .

3.7.2 Powering Down Using the Web GUI

To power down the unit:

1. Go to the **MONITOR** page.
2. Click the **Admin** button at the top left-hand corner of the screen.
3. From the **Device Administration** page, click the **Power-off Device** button located under the **Device Control** section of the screen. This will power down the unit.



Front Panel Control

Chapter 4

Contents

4.1	Introduction	4-3
4.2	Front Panel Controls.....	4-3
4.2.1	Liquid Crystal Display (LCD).....	4-3
4.2.2	Keypad	4-4
4.2.3	Status LEDs	4-4
4.3	Front Panel Menus	4-5
4.3.1	Boot-up and Monitoring Displays	4-5
4.3.2	Configuration Menu	4-6
4.3.3	Network	4-7
4.3.3.1	Restart Net	4-7
4.3.3.2	NIC1/NIC2.....	4-8
4.3.3.3	Default GW.....	4-10
4.3.3.4	NIC Bonding.....	4-11
4.3.4	Screen Config.....	4-11
4.3.5	CPU Load.....	4-12
4.3.6	Memory Usage.....	4-12
4.3.7	Uptime.....	4-12
4.3.8	Restart LCD.....	4-12
4.3.9	Reboot.....	4-13
4.3.10	Power Off	4-14
4.3.11	Software Version	4-14
4.4	Saving Your Configuration Changes.....	4-15

List of Figures

Figure 4.1	Front Panel.....	4-3
Figure 4.2	Front Panel LCD.....	4-3
Figure 4.3	Front Panel Keypad.....	4-4
Figure 4.4	Front Panel Status LEDs	4-5
Figure 4.5	Configuration Menu Tree.....	4-6

List of Tables

Table 4.1	Front Panel Keys.....	4-4
-----------	-----------------------	-----



BLANK

4.1 Introduction

This chapter describes the features provided by the Front Panel for configuring, controlling and monitoring the unit.

Note: After powering up (see *Chapter 3, Getting started*), wait for initialization to complete (approximately 1.5 to 3 minutes, depending on the number of options fitted in the chassis) before attempting to use the front panel menus and controls.

4.2 Front Panel Controls

The Front Panel provides a keypad, a display and LEDs for configuring, controlling and monitoring the unit.

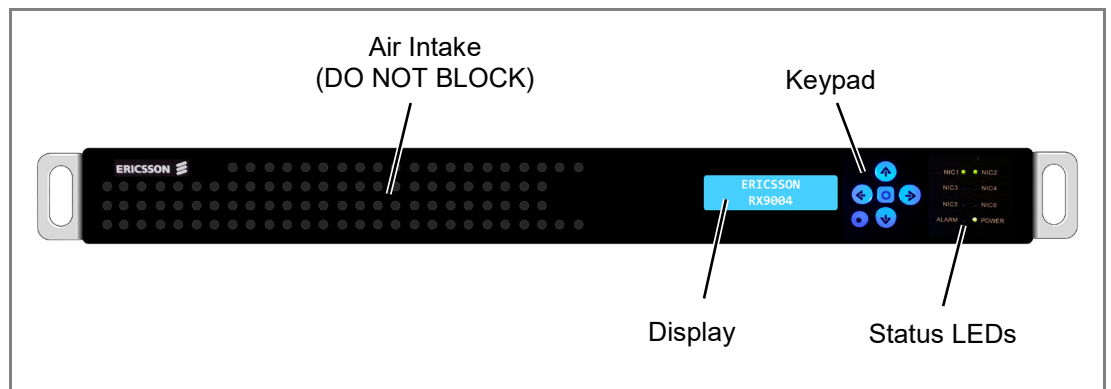

Figure 4.1 Front Panel

4.2.1 Liquid Crystal Display (LCD)

This 16 character, 2-line display screen enables configuration of the unit by selecting various pages, fields and parameters (using the Keypad). On boot-up, the LCD displays the unit type/model.



Figure 4.2 Front Panel LCD

For a description of the all the pages and parameters, see *Chapter 4, Front Panel*.

4.2.2 Keypad



The keypad provides various buttons for powering-up/shutting-down the unit, and for navigating the configuration screens.



Figure 4.3 Front Panel Keypad

The keypad functions are explained in the table below.

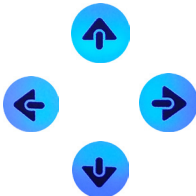
Table 4.1 Front Panel Keys

Key	Description
	<p>Navigation - The arrow keys enable you to move (up, down, left and right) within the confirmation pages, select parameters and increment or decrement their values (where applicable).</p>
	<p>Power-up - This key powers-up the unit, when pressed and held for 2 seconds. The unit will show an initial display screen showing the IP addresses for NIC1 and NIC2.</p> <p>Select – When the unit is powered up and in configuration mode, this key enables you to select the displayed submenu or displayed parameter.</p>
	<p>Configuration Mode Select – This key, when pressed, enables you to enter the configuration menu from the initial display screen.</p> <p>Shut-down – This key also shuts down the unit, when pressed and held for more than 5 seconds.</p>

4.2.3 Status LEDs

Eight LEDs display the activity on the network interfaces and the status of the equipment. (Flashing (speed?), colours (status?) or just green on/off?)



Figure 4.4 Front Panel Status LEDs

The following LEDs are provided on the front panel:

- **NIC1 – NIC6** – LED is illuminated green to indicate lock for the Network Interface Connection (NIC). NIC1 corresponds to the connector labeled LAN1 at the rear panel. NIC2 corresponds to the connector labeled LAN2 at the rear panel. (NIC4/5/6 are not used) **A flashing green light indicates speed? A red light indicates not locked?**

Note: NIC3, NIC4, NIC5, and NIC 6 are not used.

- **ALARM** – LED is illuminated (what colours?) to indicate that an alarm event. **To find out what the alarm event has been detected, go to the Front Panel Display or Web Interface.**
- **POWER** – LED is illuminated green to indicate the presence of AC power.

4.3 Front Panel Menus

4.3.1 Boot-up and Monitoring Displays

When the unit is powered up (by pressing and holding the  key), or when the unit is rebooted, the following screens are displayed on the Front Panel Display.

First the Ericsson page is displayed while the boot-up procedure is performed.



Then, when the boot-up procedure has been successfully completed, the localhost IP address is displayed. This normally takes less than a minute.

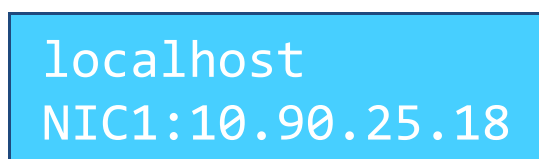

Further navigation is possible around the monitoring screen. By pressing the  key, the screen will scroll down and display the IP addresses of both NIC1 and NIC2.

```
NIC1:10.90.25.18
NIC2:192.168.15.
```

Seeing More of the Screen

To view the complete IP address, scroll right by pressing the  key.

```
10.90.25.180
192.168.15.151
```



To return to the left-most display, scroll left by pressing the  key.

4.3.2 Configuration Menu

To access the configuration menu, press the  button, at the lower left-hand corner of the keypad. The following configuration options are available.

```
Configuration
  >Network
    >Restart Net
    >NIC1
      >DHCP
      >IP
      >Netmask
      >Gateway
      >MAC
    >NIC2
      >DHCP
      >IP
      >Netmask
      >Gateway
      >MAC
    >Default GW
    >NIC Bonding
  >Screen config
  >CPU load
  >Memory usage
  >Uptime
  >Restart LCD
  >Reboot
  >Power off
  >SW version
```

Figure 4.5 Configuration Menu Tree

Menu navigation is achieved by using the keypad  and  keys.

To select a menu item, press the  button in the center of the keypad.

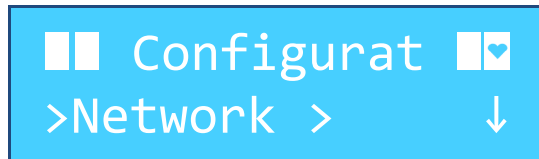

The top line of the display will automatically scroll to display the full text. For example, the text "**Configuration**".

A beating heart icon  at the right-hand side of all the configuration displays, indicates that the system is in good health.

4.3.3 Network

This menu option enables various network functions to be configured.



A sub-menu lists the available options:

- **Restart Net**
- **NIC1**
- **NIC2**
- **Default GW**
- **NIC Bonding**

To return to the previous menu, press the  key.

4.3.3.1 Restart Net

This menu option enables the restart of all the networks (NIC1 and NIC2).

Press the  key to restart the networks. A "**Please wait**" message is displayed until the task is completed, shown below. When the task is completed, the display returns to the above **Network** menu.

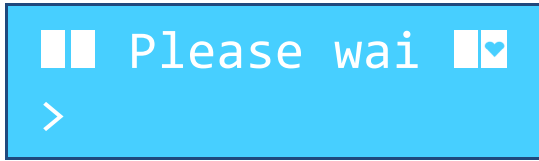

To return to the previous menu, press the  key.

4.3.3.2 NIC1/NIC2

This menu enables various network interface connection parameters to be configured.



A sub-menu lists the available options:

- DHCP
- IP
- Netmask
- Gateway
- MAC

To return to the previous menu, press the  key.

4.3.3.2.1 DHCP

This menu allows the Dynamic Host Configuration Protocol (DHCP) to be enabled/disabled. DHCP automatically configures the network settings on a host or a network device.

Press the  key to enable/disable DHCP. The box on the right-hand side of the bottom row shows the status of this feature. When the box is empty, the feature is disabled.



When the box is ticked, the feature is enabled.



To return to the previous menu, press the  key.

4.3.3.2.2



IP

This menu allows the Internet Protocol (DHCP) address settings to be configured.

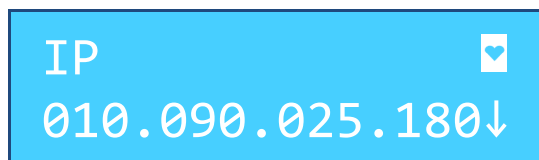
Press the  key to modify the address settings for the NIC.



The left-most digit on the bottom row will be flashing to allow you to modify it.

Press the  or  key to increment/decrement the numeric value.

Then press the  key to enter the new value and move on to the next digit.

To return to the previous menu, press the  key.

4.3.3.2.3



Netmask

This menu allows the Netmask address settings to be configured.

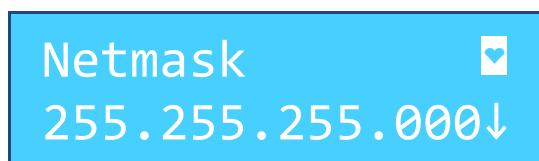
Press the  key to modify the address settings for the NIC.



The left-most digit on the bottom row will be flashing to allow you to modify it.

Press the  or  key to increment/decrement the numeric value.

Then press the  key to enter the new value and move on to the next digit.

To return to the previous menu, press the  key.



4.3.3.2.4 Gateway

This menu allows the Gateway address settings to be configured.

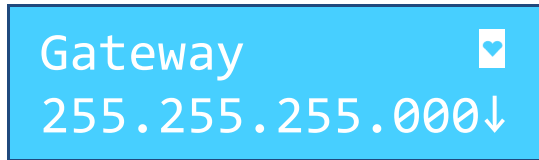
Press the  key to modify the address settings for the NIC.



The left-most digit on the bottom row will be flashing to allow you to modify it.

Press the  or  key to increment/decrement the numeric value.

Then press the  key to enter the new value and move on to the next digit.

To return to the previous menu, press the  key.

4.3.3.2.5 MAC

This menu displays the MAC address settings. No selection or modification is possible from the Front Panel.



To return to the previous menu, press the  key.

4.3.3.3 Default GW

This menu enables the default gateway address to be configured for all the NICs.



The left-most digit on the bottom row will be flashing to allow you to modify it.

Press the  or  key to increment/decrement the numeric value.

Then press the  key to enter the new value and move on to the next digit.

To return to the previous menu, press the  key.

4.3.3.4 NIC Bonding

This menu enables NIC Bonding feature to be enabled. Network Interface Card (NIC) bonding is a way to increase available bandwidth by bonding two NICs so that they appear to be the same physical device and also have the same MAC address.

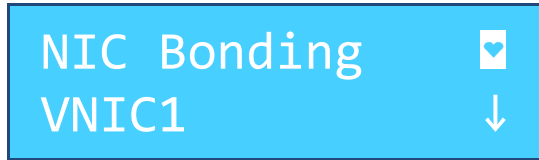

Press the  key to scroll down the various bonding options:

- VNIC1 (N1 +N3)
- VNIC2 (N2 +N4)
- VNIC3 (N5 +N6)

To return to the previous menu, press the  key.

4.3.4 Screen Config

This menu option enables a fixed hostname to be specified.

Press the  key to enable/disable Fixed hostname. The box on the right-hand side of the bottom row shows the status of this feature. When the box is empty, the feature is disabled.

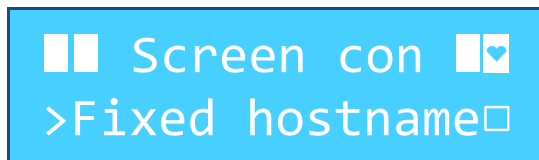

When the box is ticked, the feature is enabled.

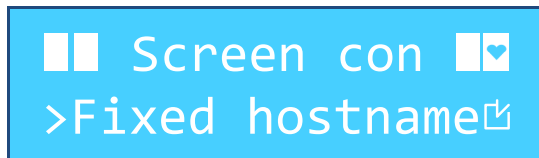

To return to the previous menu, press the  key.

4.3.5 CPU Load

This menu option displays the CPU loading (**What do these three numbers mean?**). No selection or modification is possible.

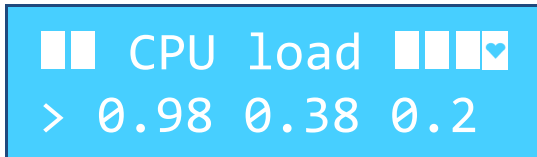

To return to the previous menu, press the  key.

4.3.6 Memory Usage

This menu option displays the memory usage (**What does this number mean?**). No selection or modification is possible.

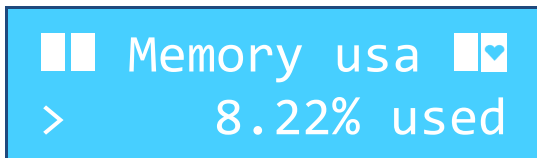

To return to the previous menu, press the  key.

4.3.7 Uptime

This menu option displays the system uptime in days, hours and minutes. No selection or modification is possible.



To return to the previous menu, press the  key.

4.3.8 Restart LCD

This menu option enables the Front Panel LCD display to be restarted (cleared) in the event of display problems.

Press the  key to begin the restart process. First the Ericsson page is displayed while the restart procedure is performed.



ERICSSON
RX9004

Then, when the restart procedure has been successfully completed, the localhost IP address is displayed (taking you out of configuration mode). This normally takes less than a minute.



localhost
NIC1:10.90.25.18

4.3.9

Reboot

This menu option enables the unit to be rebooted.

Press the  key to reboot the unit. A “**Please wait**” message is displayed while the unit is prepared for a controlled shutdown.



■ ■ Please wait ■ ■ 
>

A controlled shutdown procedure is then performed.



Shutdown ...
>

The Ericsson page is displayed when the reboot procedure is performed.



ERICSSON
RX9004

When the reboot procedure has been successfully completed, the localhost IP address is displayed (taking you out of configuration mode). This normally takes less than a minute.



localhost
NIC1:10.90.25.18

4.3.10 Power Off

This menu enables a controlled power down of the unit to be performed.

Press the  key to power down the unit. A “**Please wait**” message is displayed while the unit is prepared for a controlled shutdown.

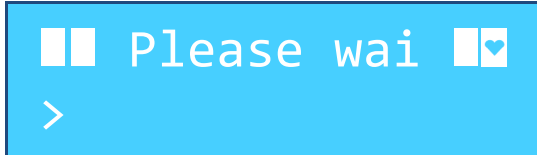

A controlled shutdown procedure is then performed.

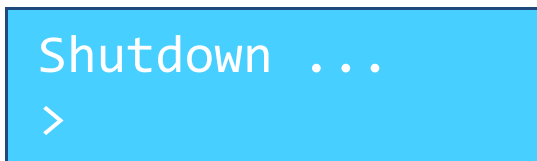

4.3.11 Software Version

This menu enables the software versions of the unit to be displayed.



Press the  key to scroll down the various software version types:

- **Man. Version** – Manufacturing build version.
- **Dec. version** – Decoder software version.
- **LCD. Version** – Liquid Crystal Display software version.

Press the  key to display the relevant software version number.

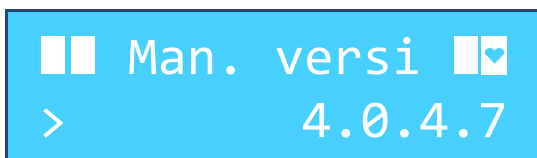



To return to the previous menu, press the  key.

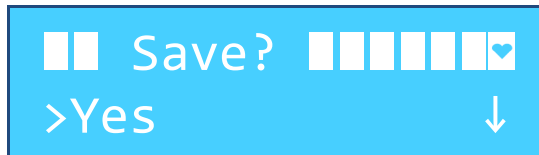

4.4 Saving Your Configuration Changes

When you have modified configuration settings the Front Panel display, return to the main menu as follows:

Press the  key repeatedly (the number of times required depends on your position in the menu tree). Before reaching the main monitoring screen, the following screen will be displayed to enable you to save your configuration changes.



With **Yes** displayed on the bottom line of the display, press the  key to save your changes.

Alternatively, press the  key to select **No**, then press the  key, if you do not want to save your changes.



BLANK



Web GUI Control

Chapter 5

Contents

5.1	Using the Web Graphical User Interface.....	5-5
5.1.1	GUI Look and Feel	5-5
5.1.1.1	Header	5-5
5.1.1.2	Pages and Tabs	5-6
5.1.1.3	Accordion Panels	5-6
5.1.2	Pages	5-6
5.2	MONITOR Page	5-7
5.2.1	Channel Monitor	5-8
5.2.2	Device Administration	5-9
5.2.3	Event Log	5-11
5.3	CONFIGURE Page.....	5-11
5.3.1	Events	5-11
5.3.2	Device	5-13
5.3.3	Roles	5-16
5.3.4	Channels	5-17
5.3.5	Video Presets	5-25
5.3.6	Audio Presets	5-29
5.4	EVENTS Page.....	5-31
5.5	SETTINGS Page	5-32
5.5.1	Settings	5-32
5.5.2	Maintenance.....	5-33
5.5.3	Update.....	5-35
5.5.4	Networking	5-37
5.5.4.1	Networking NIC Tab	5-37
5.5.4.2	Networking Advanced Tab.....	5-38
5.5.4.3	Networking VLAN Tab	5-40
5.5.4.4	Networking Services Tab.....	5-41
5.5.4.5	Networking Diagnostics Tab	5-42
5.5.5	Source Replacement.....	5-44

List of Figures

Figure 5.1	Features of the Web GUI	5-5
Figure 5.2	Header	5-6
Figure 5.3	Pages and Tabs	5-6
Figure 5.4	Accordion Panels	5-6

Figure 5.5	MONITOR Page	5-7
Figure 5.6	UDP/IP Multicast Traffic Window	5-8
Figure 5.7	Channel Monitoring Page	5-8
Figure 5.8	MONITOR > Monitor Event Log Page (Device Administration)	5-10
Figure 5.9	CONFIGURE Page.....	5-11
Figure 5.10	CONFIGURE > Events Page.....	5-13
Figure 5.11	CONFIGURE > Device Page.....	5-14
Figure 5.12	Name Settings	5-14
Figure 5.13	Basic Settings.....	5-14
Figure 5.14	Source Configuration Settings	5-15
Figure 5.15	Evergreen Settings	5-15
Figure 5.16	CONFIGURE > Roles Page.....	5-16
Figure 5.17	CONFIGURE > Roles (Channel Selection) Page.....	5-17
Figure 5.18	CONFIGURE > Channels Page.....	5-18
Figure 5.19	Profile/Channel Import Dialog	5-18
Figure 5.20	CONFIGURE > Channels (UDP/IP Channel Details) Page	5-19
Figure 5.21	CONFIGURE > Channels (ASI Channel Details) Page	5-20
Figure 5.22	Name Settings	5-20
Figure 5.23	Input Settings – UDP/IP (Left) and ASI (Right).....	5-21
Figure 5.24	Pre-processing Settings.....	5-22
Figure 5.25	Logo / Overlay Settings.....	5-23
Figure 5.26	Scrolling Text Settings	5-24
Figure 5.27	Output Settings.....	5-24
Figure 5.28	CONFIGURE > Channels (Output Details) Page	5-25
Figure 5.29	CONFIGURE > Video Presets Page.....	5-26
Figure 5.30	CONFIGURE > Video Presets (Detail) Page	5-27
Figure 5.31	Video Presets Crop Window	5-28
Figure 5.32	CONFIGURE > Audio Presets Page.....	5-29
Figure 5.33	CONFIGURE > Audio Presets (Pass-through Detail) Page.....	5-30
Figure 5.34	CONFIGURE > Audio Presets (PCM Detail) Page.....	5-30
Figure 5.35	CONFIGURE > Events Page	5-31
Figure 5.36	SETTINGS > Settings Page.....	5-32
Figure 5.37	SETTINGS > Maintenance Page	5-33
Figure 5.38	Database Maintenance Settings	5-33
Figure 5.39	User Management Settings	5-34
Figure 5.40	Management Logs Settings	5-35
Figure 5.41	Service Restart and System Reboot Settings	5-35
Figure 5.42	SETTINGS > Update Page	5-36
Figure 5.43	Decoder Firmware Update Settings	5-36
Figure 5.44	RX9004 Management System Settings	5-37
Figure 5.45	License Management Settings.....	5-37
Figure 5.46	SETTINGS > Networking Page.....	5-38
Figure 5.47	SETTINGS > Networking > Advanced Tab Page	5-39
Figure 5.48	SETTINGS > Networking > VLAN Tab Page	5-40
Figure 5.49	SETTINGS > Networking > Services Tab Page	5-41
Figure 5.50	SETTINGS > Networking > Diagnostics Tab Page	5-43
Figure 5.51	SETTINGS > Source Replacement Page	5-44
Figure 5.52	Replacement Images Settings	5-45
Figure 5.53	Replacement Playlist Settings.....	5-45

List of Tables

Table 5.1 Reference dB Conversion Table5-22

BLANK

5.1 Using the Web Graphical User Interface

The RX9004 is designed to be configured, controlled and monitored using a web-based Graphical User Interface (GUI). This chapter describes, in sequential order, the web pages and their features and functions.

5.1.1 GUI Look and Feel

The appearance and features of the web GUI are shown in *Figure 5.1*.

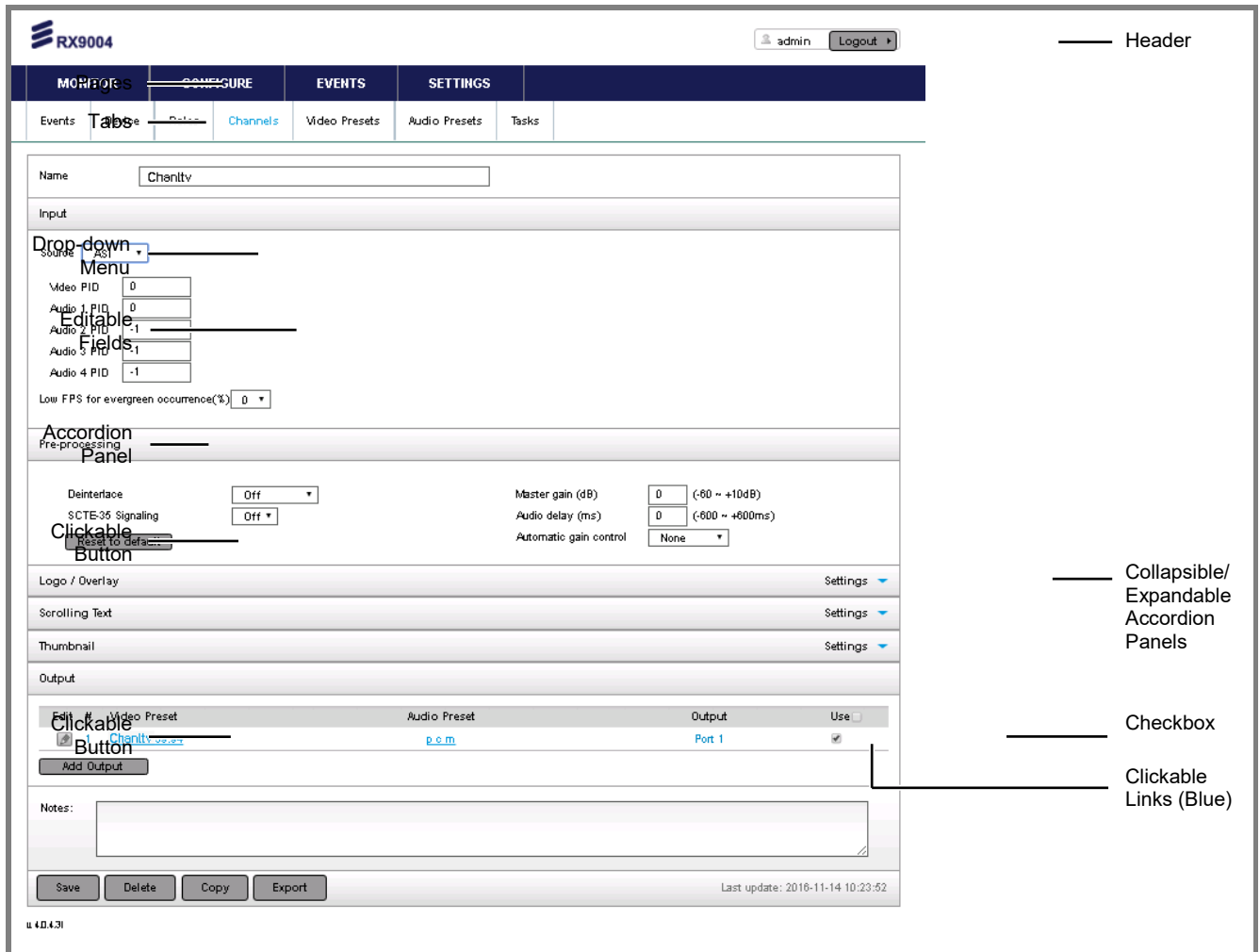

Figure 5.1 Features of the Web GUI

5.1.1.1 Header

At the top of the web GUI is a header that displays the Ericsson logo, the model number (**RX9004**) on the left-hand side. On the right-hand side is displayed the name of the user account and a **Logout** button.



Figure 5.2 Header

5.1.1.2 Pages and Tabs

Web pages are accessed by clicking on the main menu page names at the top of the navigation area at the top of the web GUI. Where appropriate, these pages are further broken down into sub-pages or tabs, displayed underneath.



Figure 5.3 Pages and Tabs

Each of the tabs, when clicked, displays its own web screen with appropriate features and functions for configuration, control and monitoring.

5.1.1.3 Accordion Panels

Many of the screens are sub-divided into sections by accordion panels that display the settings for individual functions. These panels can often be collapsed and expanded by clicking on the small arrow on the top right-hand side of the panel to enable you to display more or less information on screen.



Figure 5.4 Accordion Panels

Within the panels are editable fields, drop-down menus, tables, checkboxes and buttons to enable you to view or modify the settings. Links are also provided to take you to other screens within the web GUI.

5.1.2 Pages

The main functions of the unit are grouped into four top-level categories; each displayed on a separate page:

- MONITOR
- CONFIGURE
- EVENTS

- SETTINGS

Each main GUI page is described in the following sections.

5.2 MONITOR Page

The **MONITOR** page provides an overview of the Device and Channel status and recent operational events and alarms. Starting from this page, detailed information regarding all aspects of the deployment can be retrieved.

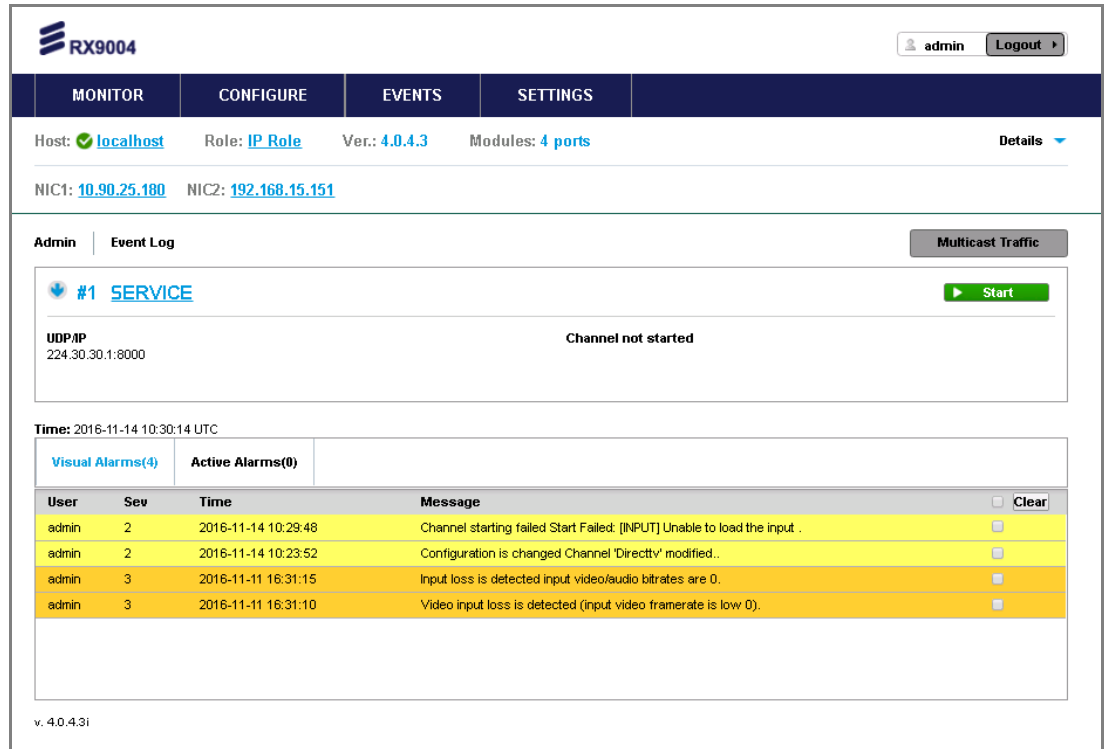

The screenshot displays the MONITOR page interface. At the top, there are navigation tabs: MONITOR, CONFIGURE, EVENTS, and SETTINGS. The main content area shows device details: Host: localhost (with a green checkmark), Role: IP Role, Ver.: 4.0.4.3, and Modules: 4 ports. Below this, network interfaces are listed: NIC1: 10.90.25.180 and NIC2: 192.168.15.151. A section for 'Admin' and 'Event Log' is visible, with a 'Multicast Traffic' button. The central part of the page shows a service status for '#1 SERVICE' with a 'Start' button and the message 'Channel not started'. Below the service status, there is a table for 'Visual Alarms(4)' and 'Active Alarms(0)'. The table has columns for User, Sev, Time, and Message, and includes a 'Clear' button. The messages in the table are:

User	Sev	Time	Message	Clear
admin	2	2016-11-14 10:29:48	Channel starting failed Start Failed: [INPUT] Unable to load the input .	<input type="checkbox"/>
admin	2	2016-11-14 10:23:52	Configuration is changed Channel 'Directv' modified..	<input type="checkbox"/>
admin	3	2016-11-11 16:31:15	Input loss is detected input video/audio bitrates are 0.	<input type="checkbox"/>
admin	3	2016-11-11 16:31:10	Video input loss is detected (input video framerate is low 0).	<input type="checkbox"/>

At the bottom left of the page, the version 'v. 4.0.4.3i' is displayed.

Figure 5.5 MONITOR Page

The topmost section of the page displays information about the Device and allows for starting and stopping all Channels at once, using the **Start/Stop All** button.

- **Host** – The name of the selected Device. Clicking on the link brings up the Device Configuration View.
- **Role** – The Role currently assigned. Clicking on the link brings up the Role Configuration View.
- **Mode** – Indicates whether the Device is in Active or Manual mode in respect to redundancy and failover. Use the selection box and Change Mode button to change the mode of the Device.
- **Status** – Indicates whether the Device is currently accessible. A Device in OFF status displays minimal information.
- **Version** – The firmware version of the Device.

- **Modules** – The hardware configuration of the Device. The numbers indicate the number of modules detected and the hardware version respectively.
- **NIC1/2/3/4/5/6** – Displays the IP addresses assigned to all configured NICs.

The **Multicast Traffic** button at the top right provides information regarding the UDP/IP multicast traffic currently available to the Device. It is mainly used for troubleshooting purposes. When clicked, a pop-up window is presented with all the related information, as shown below. Note that IGMPv3 enabled networks may not register multicast traffic with this tool, unless the specific multicast is actively used/consumed by the Device. The **Multicast Traffic** button is only available when one or more of the Channels in the Device are configured with UDP/IP source. (new image required?)

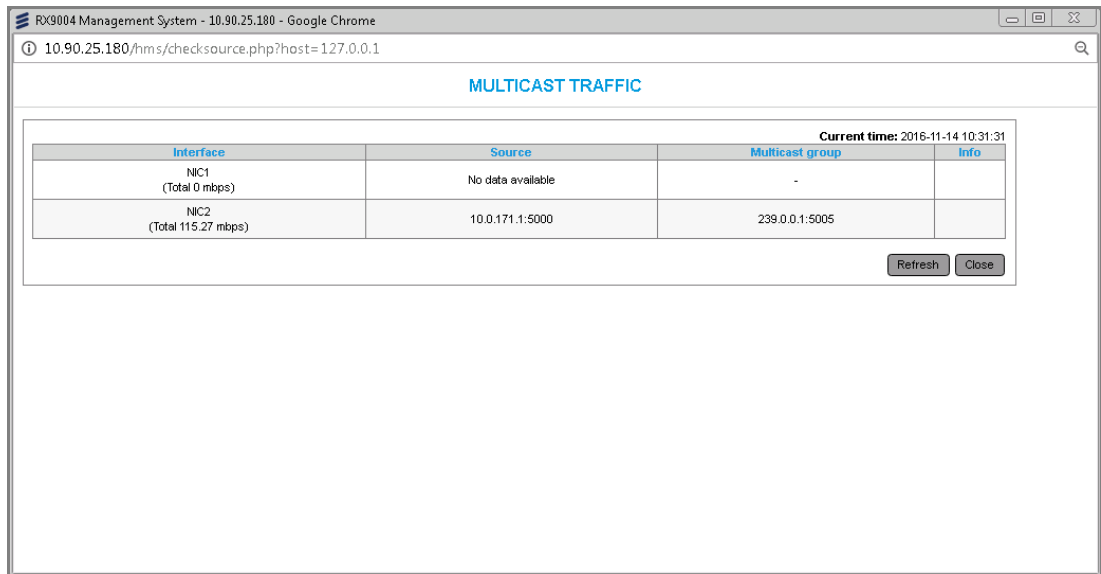

Figure 5.6 UDP/IP Multicast Traffic Window

5.2.1 Channel Monitor

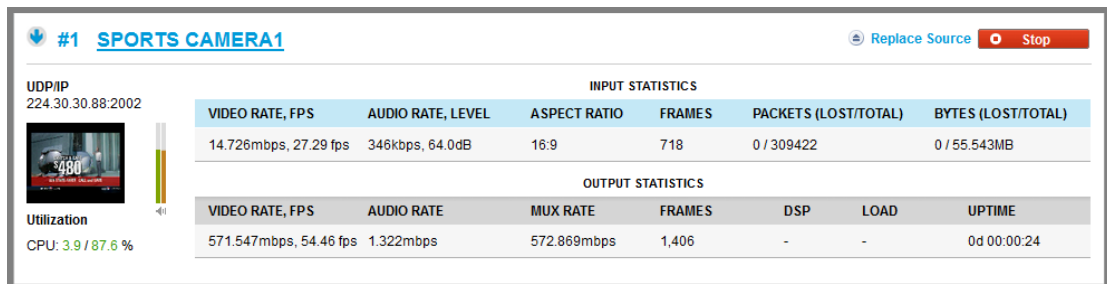

Figure 5.7 Channel Monitoring Page

The top part provides statistics regarding the input properties while the bottom list refers to the outputs. Each row corresponds to a separate Output and the first column displays the Outputs. Further, for each running Channel:



- A thumbnail is displayed every few seconds, to indicate the status/quality of the source
- Below the thumbnail, the CPU utilization is displayed. The first figure shows the CPU % used by the current channel, while the second figure shows the overall idle CPU power.
- A link to the Channel Configuration View is available.
- A Start/Stop button is available to individually control each Channel.

Clicking on the blue underline Channel name allows for direct Channel editing. Changes to running Channels won't take effect until the next Channel restart or by using other mechanisms depending upon the type of the change (run-time set options).

Clicking on the downwards arrow in front of the Channel name switches the page to Channel Preview mode where all details regarding the configuration and outputs of the Channel are displayed. This provides for a quick way to overview the Channel's configuration and spot mistakes.

5.2.2

Device Administration

Click the **Admin** link on the top left-hand side of the **MONITOR** page to access the **Device Administration** page. The **Device Administration** page enables firmware and license updates to be applied.

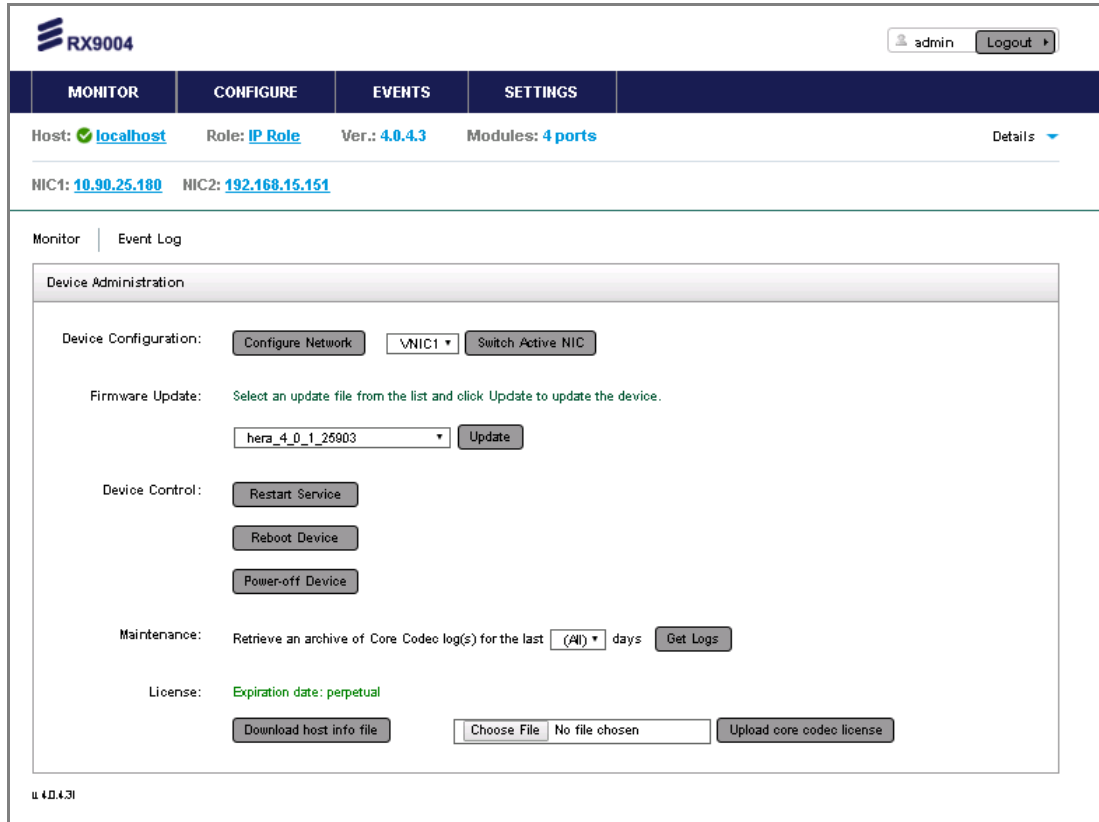

Figure 5.8 MONITOR > Monitor Event Log Page (Device Administration)

This screen provides the following features:

- **Device Configuration** – The **Configure Network** button enables NIC selection and permits NIC bonding. The **Switch Active NIC** button enables the NIC selected in the drop-down list to be made active.
- **Firmware Update** – A drop-down list details the available Decoder firmware files and the **Update** button enables the device to be updated with the selected firmware file (Decoder firmware must first be Uploaded using the **SETTINGS > Update** page). Firmware cannot be downgraded to previous old versions.
- **Device Control** – Three control buttons are provided:
 - The **Restart Service** button enables the stopping and rerunning the decoder application and its management program.
 - The **Reboot Device** button enables the server hardware to be rebooted, which may be required after some upgrade procedures.
 - The **Power-off Device** button performs a controlled shuts down of the hardware.
- **Maintenance** – The **Get Logs** button enables an archive of core codec logs to be retrieved. A drop-down list enables the number of days to be selected.

- **License** –The **Download host info file** button enables core decoder host file to be downloaded to generate License file. The **Upload core codec license** button enables the selected license file to be uploaded.

5.2.3 Event Log

Click the **Event Log** link on the top left-hand side of the Device Monitor page to access the Event Viewer tab with pre-filtered event logs regarding the current Device. For more details regarding using the Event Viewer Tab, see section 5.4 *EVENTS Page*.

5.3 CONFIGURE Page

The CONFIGURE page provides access to detailed configuration settings.

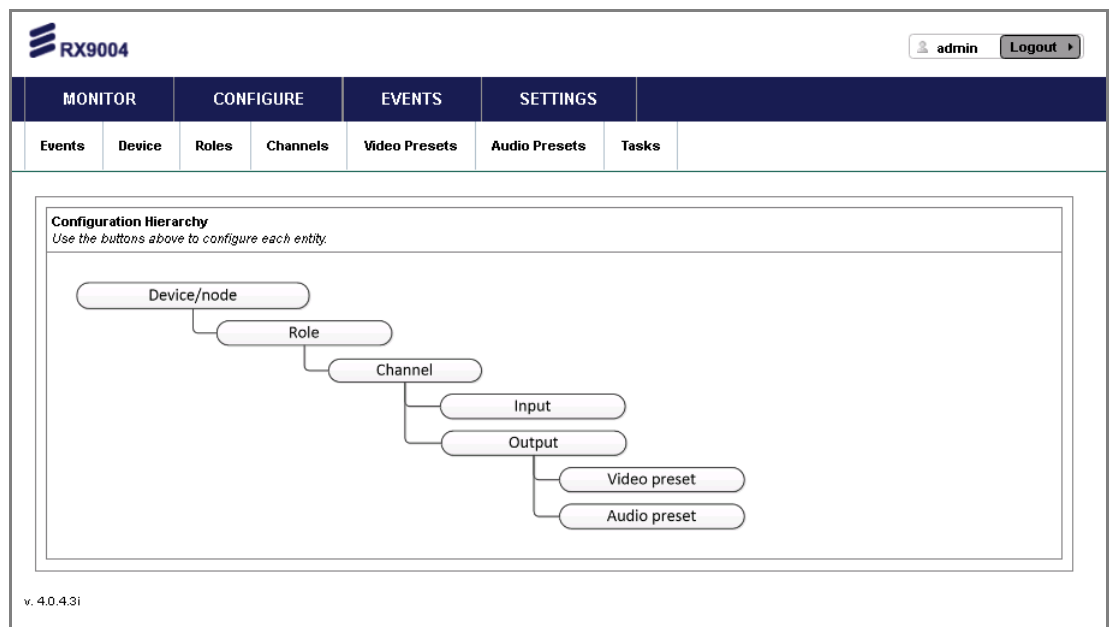



Figure 5.9 CONFIGURE Page

The diagram represents the hierarchy and inter-dependencies among the building blocks. The RX9004 ships with several building blocks pre-configured, however, each deployment has its own requirements and modifications/adjustments are always needed.

5.3.1 Events

This page enables you to configure/modify the alarm severity and indicated responses to all the anticipated events.

To make changes to these event, simply select the appropriate settings and then click the **Save** button at the bottom of the page.

admin Logout

MONITOR
CONFIGURE
EVENTS
SETTINGS

Events
Device
Roles
Channels
Video Presets
Audio Presets
Tasks

High Availability Policy

- On Device-Management Link Loss:
 - Device continues running : Actions(failover/restart/stop) by 'Management NIC link down' event will be disabled.
 - Device stops running : Please choose this for using failover policy.

Event Configuration [Set to default](#)

Name	Severity LOW ▼	Trigger Condition	Failover(Prior.1)	Restart(Prior.2)	Stop(Prior.3)	Audio Alarm	Visual Alarm	Active Alarm	Email/SMS
NIC link down	HIGH ▼		<input type="checkbox"/>	<input type="checkbox"/>	<input type="checkbox"/>	<input checked="" type="checkbox"/>	<input checked="" type="checkbox"/>	<input checked="" type="checkbox"/>	<input type="checkbox"/>
Input NIC link down	HIGH ▼		<input checked="" type="checkbox"/>	<input type="checkbox"/>	<input type="checkbox"/>	<input checked="" type="checkbox"/>	<input checked="" type="checkbox"/>	<input checked="" type="checkbox"/>	<input type="checkbox"/>
Output NIC link down	HIGH ▼		<input type="checkbox"/>	<input type="checkbox"/>	<input type="checkbox"/>	<input checked="" type="checkbox"/>	<input checked="" type="checkbox"/>	<input checked="" type="checkbox"/>	<input type="checkbox"/>
Output NICs are all down	HIGH ▼		<input checked="" type="checkbox"/>	<input type="checkbox"/>	<input type="checkbox"/>	<input checked="" type="checkbox"/>	<input checked="" type="checkbox"/>	<input checked="" type="checkbox"/>	<input type="checkbox"/>
Management NIC link down	HIGH ▼		<input checked="" type="checkbox"/>	<input type="checkbox"/>	<input type="checkbox"/>	<input checked="" type="checkbox"/>	<input checked="" type="checkbox"/>	<input checked="" type="checkbox"/>	<input type="checkbox"/>
Bonding NIC switched	HIGH ▼		<input type="checkbox"/>	<input type="checkbox"/>	<input type="checkbox"/>	<input checked="" type="checkbox"/>	<input checked="" type="checkbox"/>		<input type="checkbox"/>
Input bonding NIC switched	HIGH ▼		<input type="checkbox"/>	<input type="checkbox"/>	<input type="checkbox"/>	<input checked="" type="checkbox"/>	<input checked="" type="checkbox"/>		<input type="checkbox"/>
Output bonding NIC switched	HIGH ▼		<input type="checkbox"/>	<input type="checkbox"/>	<input type="checkbox"/>	<input checked="" type="checkbox"/>	<input checked="" type="checkbox"/>		<input type="checkbox"/>
Management bonding NIC switched	HIGH ▼		<input type="checkbox"/>	<input type="checkbox"/>	<input type="checkbox"/>	<input checked="" type="checkbox"/>	<input checked="" type="checkbox"/>		<input type="checkbox"/>
Failover failed	HIGH ▼		<input checked="" type="checkbox"/>	<input type="checkbox"/>	<input type="checkbox"/>	<input checked="" type="checkbox"/>	<input checked="" type="checkbox"/>		<input type="checkbox"/>
Failover failed. No standby	HIGH ▼		<input type="checkbox"/>	<input checked="" type="checkbox"/>	<input checked="" type="checkbox"/>	<input checked="" type="checkbox"/>	<input checked="" type="checkbox"/>		<input type="checkbox"/>
HDD doesn't support SMART	MED ▼		<input type="checkbox"/>	<input type="checkbox"/>	<input type="checkbox"/>	<input checked="" type="checkbox"/>	<input checked="" type="checkbox"/>		<input type="checkbox"/>
HDD has an error. Please replace the HDD	HIGH ▼		<input type="checkbox"/>	<input type="checkbox"/>	<input type="checkbox"/>	<input checked="" type="checkbox"/>	<input checked="" type="checkbox"/>		<input type="checkbox"/>
HDD temperature is too high	MED ▼		<input type="checkbox"/>	<input type="checkbox"/>	<input type="checkbox"/>	<input checked="" type="checkbox"/>	<input checked="" type="checkbox"/>	<input checked="" type="checkbox"/>	<input type="checkbox"/>
HDD state is wrong	MED ▼		<input type="checkbox"/>	<input type="checkbox"/>	<input type="checkbox"/>	<input checked="" type="checkbox"/>	<input checked="" type="checkbox"/>	<input checked="" type="checkbox"/>	<input type="checkbox"/>
HDD space is low	MED ▼		<input type="checkbox"/>	<input type="checkbox"/>	<input type="checkbox"/>	<input checked="" type="checkbox"/>	<input checked="" type="checkbox"/>	<input checked="" type="checkbox"/>	<input type="checkbox"/>
CPU load is too high	MED ▼		<input type="checkbox"/>	<input type="checkbox"/>	<input type="checkbox"/>	<input checked="" type="checkbox"/>	<input checked="" type="checkbox"/>	<input checked="" type="checkbox"/>	<input type="checkbox"/>
Free memory is low	MED ▼		<input type="checkbox"/>	<input type="checkbox"/>	<input type="checkbox"/>	<input checked="" type="checkbox"/>	<input checked="" type="checkbox"/>	<input checked="" type="checkbox"/>	<input type="checkbox"/>
Free high memory is low	MED ▼		<input type="checkbox"/>	<input type="checkbox"/>	<input type="checkbox"/>	<input checked="" type="checkbox"/>	<input checked="" type="checkbox"/>	<input checked="" type="checkbox"/>	<input type="checkbox"/>
Free low memory is low	MED ▼		<input type="checkbox"/>	<input type="checkbox"/>	<input type="checkbox"/>	<input checked="" type="checkbox"/>	<input checked="" type="checkbox"/>	<input checked="" type="checkbox"/>	<input type="checkbox"/>
Failover completed successfully	HIGH ▼		<input type="checkbox"/>	<input type="checkbox"/>	<input type="checkbox"/>	<input checked="" type="checkbox"/>	<input checked="" type="checkbox"/>		<input type="checkbox"/>
Checked duplicated HMS	HIGH ▼		<input type="checkbox"/>	<input type="checkbox"/>	<input type="checkbox"/>	<input checked="" type="checkbox"/>	<input checked="" type="checkbox"/>		<input type="checkbox"/>
Power supply is failed	MED ▼		<input type="checkbox"/>	<input type="checkbox"/>	<input type="checkbox"/>	<input checked="" type="checkbox"/>	<input checked="" type="checkbox"/>	<input checked="" type="checkbox"/>	<input type="checkbox"/>
File descriptors exceeded	HIGH ▼		<input type="checkbox"/>	<input type="checkbox"/>	<input type="checkbox"/>	<input checked="" type="checkbox"/>	<input checked="" type="checkbox"/>	<input checked="" type="checkbox"/>	<input type="checkbox"/>
CPU temperature is too high	HIGH ▼		<input type="checkbox"/>	<input type="checkbox"/>	<input type="checkbox"/>	<input checked="" type="checkbox"/>	<input checked="" type="checkbox"/>	<input checked="" type="checkbox"/>	<input type="checkbox"/>
Time is changed	MED ▼		<input type="checkbox"/>	<input type="checkbox"/>	<input type="checkbox"/>	<input type="checkbox"/>	<input checked="" type="checkbox"/>		<input type="checkbox"/>
Time can't be changed	MED ▼		<input type="checkbox"/>	<input type="checkbox"/>	<input type="checkbox"/>	<input checked="" type="checkbox"/>	<input checked="" type="checkbox"/>		<input type="checkbox"/>
Timezone is changed	MED ▼		<input type="checkbox"/>	<input type="checkbox"/>	<input type="checkbox"/>	<input type="checkbox"/>	<input checked="" type="checkbox"/>		<input type="checkbox"/>
Timezone can't be changed	MED ▼		<input type="checkbox"/>	<input type="checkbox"/>	<input type="checkbox"/>	<input checked="" type="checkbox"/>	<input checked="" type="checkbox"/>		<input type="checkbox"/>
SNMP configuration is changed	HIGH ▼		<input type="checkbox"/>	<input type="checkbox"/>	<input type="checkbox"/>	<input type="checkbox"/>	<input checked="" type="checkbox"/>		<input type="checkbox"/>
SNMP trap module has an error	MED ▼		<input type="checkbox"/>	<input type="checkbox"/>	<input type="checkbox"/>	<input type="checkbox"/>	<input checked="" type="checkbox"/>		<input type="checkbox"/>
Service is restarted	MED ▼		<input type="checkbox"/>	<input type="checkbox"/>	<input type="checkbox"/>	<input type="checkbox"/>	<input checked="" type="checkbox"/>		<input type="checkbox"/>
Device version is changed	MED ▼		<input type="checkbox"/>	<input type="checkbox"/>	<input type="checkbox"/>	<input type="checkbox"/>	<input checked="" type="checkbox"/>		<input type="checkbox"/>
Device is restarted	MED ▼		<input type="checkbox"/>	<input type="checkbox"/>	<input type="checkbox"/>	<input type="checkbox"/>	<input checked="" type="checkbox"/>		<input type="checkbox"/>
Device is powered off	HIGH ▼		<input type="checkbox"/>	<input type="checkbox"/>	<input type="checkbox"/>	<input checked="" type="checkbox"/>	<input checked="" type="checkbox"/>		<input type="checkbox"/>
Input loss is detected	HIGH ▼		<input checked="" type="checkbox"/>	<input type="checkbox"/>	<input type="checkbox"/>	<input checked="" type="checkbox"/>	<input checked="" type="checkbox"/>	<input checked="" type="checkbox"/>	<input type="checkbox"/>
Video input loss is detected	HIGH ▼		<input checked="" type="checkbox"/>	<input type="checkbox"/>	<input type="checkbox"/>	<input checked="" type="checkbox"/>	<input checked="" type="checkbox"/>	<input checked="" type="checkbox"/>	<input type="checkbox"/>
Audio input loss is detected	HIGH ▼		<input checked="" type="checkbox"/>	<input type="checkbox"/>	<input type="checkbox"/>	<input checked="" type="checkbox"/>	<input checked="" type="checkbox"/>	<input checked="" type="checkbox"/>	<input type="checkbox"/>
Evergreen occurred	HIGH ▼		<input type="checkbox"/>	<input type="checkbox"/>	<input type="checkbox"/>	<input type="checkbox"/>	<input checked="" type="checkbox"/>	<input checked="" type="checkbox"/>	<input type="checkbox"/>
Video freeze is detected	HIGH ▼		<input type="checkbox"/>	<input type="checkbox"/>	<input type="checkbox"/>	<input checked="" type="checkbox"/>	<input checked="" type="checkbox"/>	<input checked="" type="checkbox"/>	<input type="checkbox"/>

Video freeze is detected	HIGH ▾	<input type="checkbox"/>	<input type="checkbox"/>	<input type="checkbox"/>	<input checked="" type="checkbox"/>	<input checked="" type="checkbox"/>	<input checked="" type="checkbox"/>	<input type="checkbox"/>
Silence audio is detected	HIGH ▾	<input type="checkbox"/>	<input type="checkbox"/>	<input type="checkbox"/>	<input checked="" type="checkbox"/>	<input checked="" type="checkbox"/>	<input checked="" type="checkbox"/>	<input type="checkbox"/>
Source is replaced	HIGH ▾	<input type="checkbox"/>	<input type="checkbox"/>	<input type="checkbox"/>	<input checked="" type="checkbox"/>	<input checked="" type="checkbox"/>	<input checked="" type="checkbox"/>	<input type="checkbox"/>
Video source is replaced	HIGH ▾	<input type="checkbox"/>	<input type="checkbox"/>	<input type="checkbox"/>	<input checked="" type="checkbox"/>	<input checked="" type="checkbox"/>	<input checked="" type="checkbox"/>	<input type="checkbox"/>
Audio source is replaced	HIGH ▾	<input type="checkbox"/>	<input type="checkbox"/>	<input type="checkbox"/>	<input checked="" type="checkbox"/>	<input checked="" type="checkbox"/>	<input checked="" type="checkbox"/>	<input type="checkbox"/>
Logo files are not found	LOW ▾	<input type="checkbox"/>	<input type="checkbox"/>	<input type="checkbox"/>	<input checked="" type="checkbox"/>	<input checked="" type="checkbox"/>	<input type="checkbox"/>	<input type="checkbox"/>
Input video is not decoded properly	HIGH ▾	<input checked="" type="checkbox"/>	<input type="checkbox"/>	<input type="checkbox"/>	<input checked="" type="checkbox"/>	<input checked="" type="checkbox"/>	<input type="checkbox"/>	<input type="checkbox"/>
Transcoder process is not running	HIGH ▾	<input type="checkbox"/>	<input checked="" type="checkbox"/>	<input type="checkbox"/>	<input checked="" type="checkbox"/>	<input checked="" type="checkbox"/>	<input type="checkbox"/>	<input type="checkbox"/>
Invalid status	HIGH ▾	<input checked="" type="checkbox"/>	<input type="checkbox"/>	<input type="checkbox"/>	<input checked="" type="checkbox"/>	<input checked="" type="checkbox"/>	<input type="checkbox"/>	<input type="checkbox"/>
Channel starting failed	MED ▾	<input type="checkbox"/>	<input type="checkbox"/>	<input checked="" type="checkbox"/>	<input checked="" type="checkbox"/>	<input checked="" type="checkbox"/>	<input type="checkbox"/>	<input type="checkbox"/>
Recording failed	MED ▾	<input type="checkbox"/>	<input type="checkbox"/>	<input type="checkbox"/>	<input checked="" type="checkbox"/>	<input checked="" type="checkbox"/>	<input type="checkbox"/>	<input type="checkbox"/>
Low video output	HIGH ▾	<input checked="" type="checkbox"/>	<input type="checkbox"/>	<input type="checkbox"/>	<input checked="" type="checkbox"/>	<input checked="" type="checkbox"/>	<input type="checkbox"/>	<input type="checkbox"/>
Low audio output	HIGH ▾	<input checked="" type="checkbox"/>	<input type="checkbox"/>	<input type="checkbox"/>	<input checked="" type="checkbox"/>	<input checked="" type="checkbox"/>	<input type="checkbox"/>	<input type="checkbox"/>
Channel started	LOW ▾	<input type="checkbox"/>	<input type="checkbox"/>	<input type="checkbox"/>	<input type="checkbox"/>	<input type="checkbox"/>	<input type="checkbox"/>	<input type="checkbox"/>
Channel stopped	LOW ▾	<input type="checkbox"/>	<input type="checkbox"/>	<input type="checkbox"/>	<input type="checkbox"/>	<input type="checkbox"/>	<input type="checkbox"/>	<input type="checkbox"/>
Recording started	LOW ▾	<input type="checkbox"/>	<input type="checkbox"/>	<input type="checkbox"/>	<input type="checkbox"/>	<input type="checkbox"/>	<input type="checkbox"/>	<input type="checkbox"/>
Recording stopped	LOW ▾	<input type="checkbox"/>	<input type="checkbox"/>	<input type="checkbox"/>	<input type="checkbox"/>	<input type="checkbox"/>	<input type="checkbox"/>	<input type="checkbox"/>
Manual failover requested	MED ▾	<input type="checkbox"/>	<input type="checkbox"/>	<input type="checkbox"/>	<input checked="" type="checkbox"/>	<input checked="" type="checkbox"/>	<input type="checkbox"/>	<input type="checkbox"/>

Notes:

Last update: 2016-09-06 20:50:01

Figure 5.10 CONFIGURE > Events Page

5.3.2 Device

The **Device** page enables the usage of the RX9004 unit to be specified.

The top part of the page controls the basic settings and information for the Device, more details are presented below.

The middle part provides configuration tools for the setup of each source/input associated with the Channels allocated to the specific Device.

The bottom part controls the integration with IP switches and ASI/SDI routers and is only applicable when switch/router control is needed (**Disabled ASI/SDI router?**).

Figure 5.11 CONFIGURE > Device Page

Name

Figure 5.12 Name Settings

This panel provides the following features:

- **Name** – A name to uniquely identify the Device.

Basic Settings

Figure 5.13 Basic Settings

This panel provides the following features:

- **Role** – A name to uniquely identify the Role.
- **IPMI Address** – The IP address of the first available network interface (physical or virtual).

- **Max channels** – Specifies the maximum number of channels that may be used by the unit.

Source Configuration

This table reflects the relationships between the physical inputs/plugs of the Device and the associated Channels. This table is updated each time the Role of the Device changes and reflects the source-types indicated in the Channel configuration settings:

Channel	Source	Evergreen	Video ID	Audio ID	Analyze	Auto Restore
1	Charity	UDP: 224.30.30.1:8000	<input type="button" value="Change"/>	<input type="text" value="0"/>	Track1: <input type="text" value="0"/>	<input type="button" value="Scan"/> <input checked="" type="checkbox"/>

Notes:

Last update: 2016-11-14 10:43:30

Figure 5.14 Source Configuration Settings

The Evergreen **Change** button, allows you to define the behavior of the specific channel in cases of input loss. The button is only enabled for Channels that are not currently in running state.

EVERGREEN

Source replacement strategy

Video: Blue screen Static image

Audio: No audio (mute) Source audio (don't mute, keep source) -20dB 1kHz Tone

Static image

Images:

Figure 5.15 Evergreen Settings

The operator can define what content is to be delivered in case of source outage. The options for the video range from a blue screen to a still image, while the audio can be muted, kept as is, or replaced by a 1 kHz tone.

The switchover is performed using the **Replace Source** button in the Device Monitor page. This helps mask a long source outage by providing audience with alternative content. The pre-configuration step ensures that no mistakes are made at production time (e.g. load content that is not authorized or appropriate for the channel).

Back at the Device Configuration Dialog, the Auto Restore check box at the very last column controls whether the Channel automatically resumes to the live content once it is available, or instead remains in Evergreen Mode until the Operator manually switches it back to the live source. In an unattended deployment, the Auto Restore box needs to be checked for all channels. However, in a 24x7 monitored deployment, the Operator may choose to assume control of the channel restore time and ensure that the outage is fully addressed before switching back to live feed (and avoid frequent evergreen-live switchovers as the problem is being worked on).

5.3.3 Roles

A Role is a collection of channels. Roles are assigned to RX9004 devices to deliver the associated channels/outputs. A Role can therefore be assigned to several units at the same time, but a single unit can only have one Role at any given time.

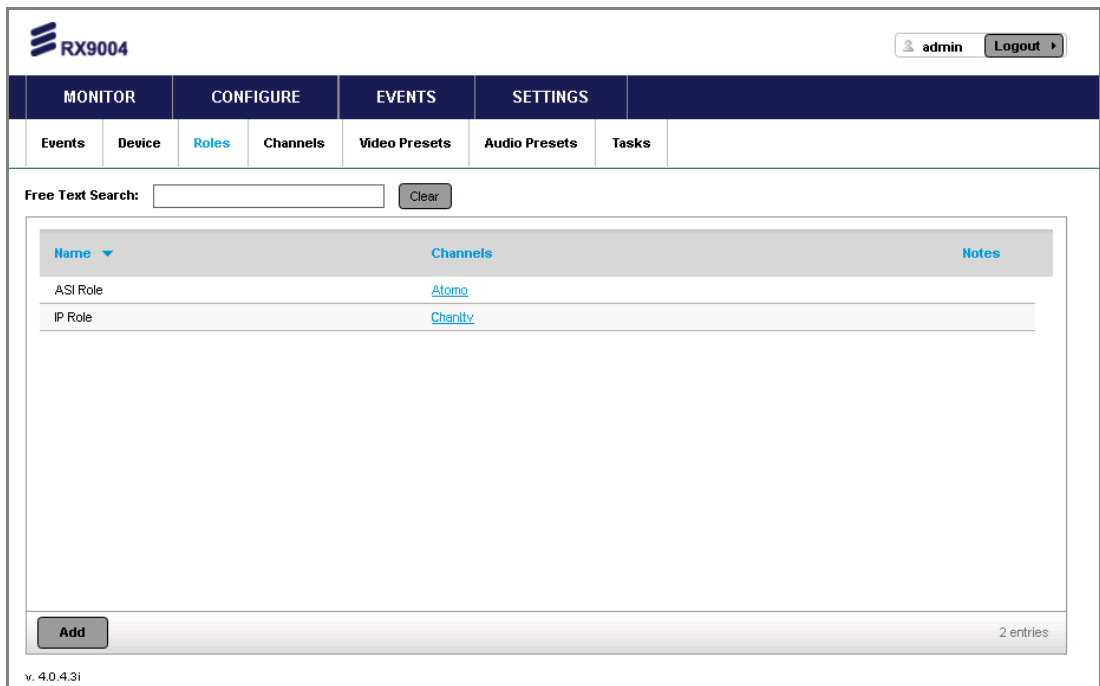

Name	Channels	Notes
ASI Role	Atomo	
IP Role	Chantlv	

v. 4.0.4.31

Figure 5.16 CONFIGURE > Roles Page

The Roles page lists the currently configured Roles with details about their respective channels. Clicking directly on a Channel link brings up the configuration options of the Channel. Roles can be edited by clicking on the corresponding row. New ones can be added by clicking the **Add** button at the bottom of the page.

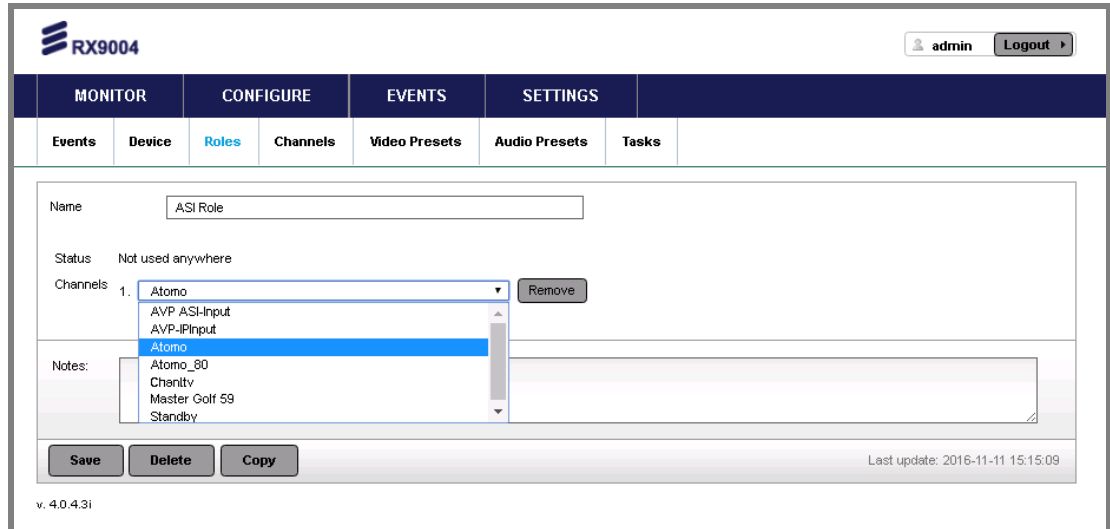

Figure 5.17 CONFIGURE > Roles (Channel Selection) Page

This screen provides the following features:

- **Name** – A name to uniquely identify the Role.
- **Status** – Read-only field to indicate whether the Role is in use by any Device and whether that Device is currently in Running state. When a Channel in a Role is in Running State, it is shown as read-only and only changes to non-running Channels are permitted.
- **Channels** – Select one or more channels to include in the Role. Use the Remove button on the right to remove a Channel from the Role.
- **Notes** – This field is reserved for user notes or comments.

Note: A Role with one or more standby channels/slots is not permitted to be assigned to more than one Device. A warning message will appear and the operation will be aborted.

5.3.4 Channels

A Channel is a processing task with a single input and one or more output streams. Each output uses a video and an audio preset. Multiple Channels can use the same audio and/or video presets and any change to those presets (e.g. bit-rate) affects all associated channels automatically.

The **Channels** page displays a list of the currently available channels with details about their respective settings.

Name	Source	Video PID	Audio PID	Output Count	Notes
Atomo	ASI	101	102	1	
Atomo_80	ASI	481	0	1	
AVP-ASI-Input	UDP: 239.0.0.1:5005	102	103	1	
AVP-IPInput	UDP: 239.0.0.1:5005	102	103	1	
Charity	UDP: 224.30.30.1:8000	0	0	1	
Master Golf 59	ASI	481	482	1	

Figure 5.18 CONFIGURE > Channels Page

Channels can be edited by clicking on the corresponding row or new ones can be added by clicking the **Add** button at the bottom of the page.

An **Import** button is available to upload an XML-based configuration file that has been generated/edited manually or by a 3rd party application/automation.

Figure 5.19 Profile/Channel Import Dialog

Note: When a channel is imported, all its associated video and audio presets are also imported automatically. If any of those preset names are already available in the database, the existing presets are updated/overwritten. Once the import is completed, a warning message is shown to indicate the presets that have been updated/overwritten.

When a channel is selected for editing, the screen displays the appropriate settings for the type selected. The top section controls the input/source parameters, the middle one the post-processing tools and the bottom section displays the settings of each output. (New image required – some options disabled)

 RX9004
admin [Logout](#)

MONITOR
CONFIGURE
EVENTS
SETTINGS

Events
Device
Roles
Channels
Video Presets
Audio Presets
Tasks

Name

Input

Source

Enable TS over RTP
 Start with Evergreen
 ProMpeg

Network URL

Network Backup URL

Tolerance Time (100 ~ 1000 ms)

Interface for routing

Bonding Failover

Video PID

Audio 1 PID

Audio 2 PID

Audio 3 PID

Audio 4 PID

Low FPS for evergreen occurrence(%)

Pre-processing

Deinterlace
 SCTE-35 Signaling

Master gain (dB) (-60 ~ +10dB)
 Audio delay (ms) (-600 ~ +600ms)
 Automatic gain control

Logo / Overlay [Settings](#)

Scrolling Text [Settings](#)

Thumbnail [Settings](#)

Output

Edit	#	Video Preset	Audio Preset	Output	Use
	1	Chanitv 59.94	p.c.m	Port 1	<input checked="" type="checkbox"/>

Notes:

Last update: 2016-11-14 10:23:52

v 4.0.4.31

Figure 5.20 CONFIGURE > Channels (UDP/IP Channel Details) Page

1/1553-FGC 101 3287 Uen A

5-19

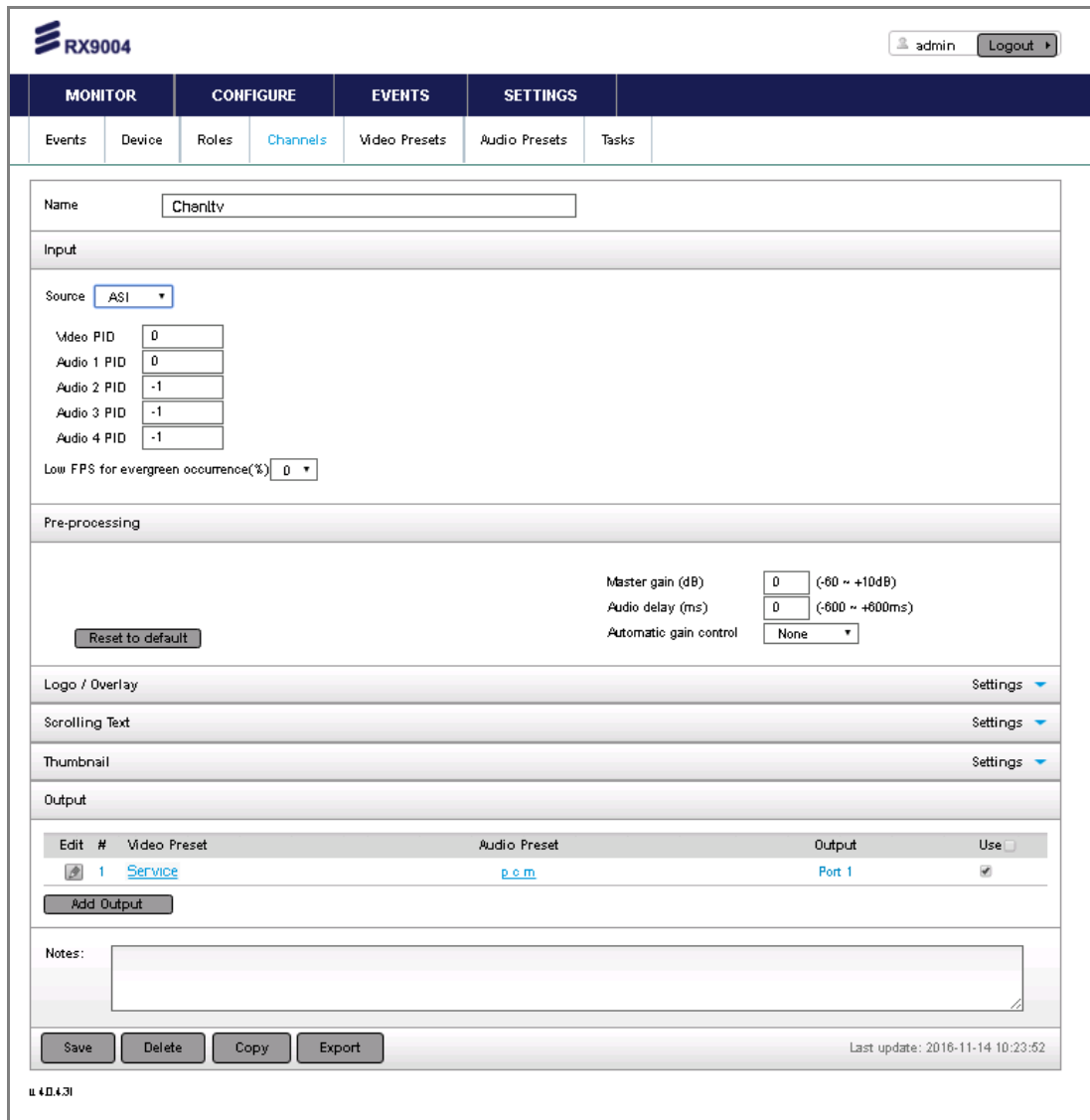

Figure 5.21 CONFIGURE > Channels (ASI Channel Details) Page

This screen provides the following features, depending on the type of channel preset selected (New image required – some options disabled?):

Name

The name editable field allows a memorable identifier to be assigned to the channel.



Figure 5.22 Name Settings

- **Name** – A name to uniquely identify the channel.

Input

The **Input** panel allows the input source to be specified for decoding (**New image required – some options disabled?**).

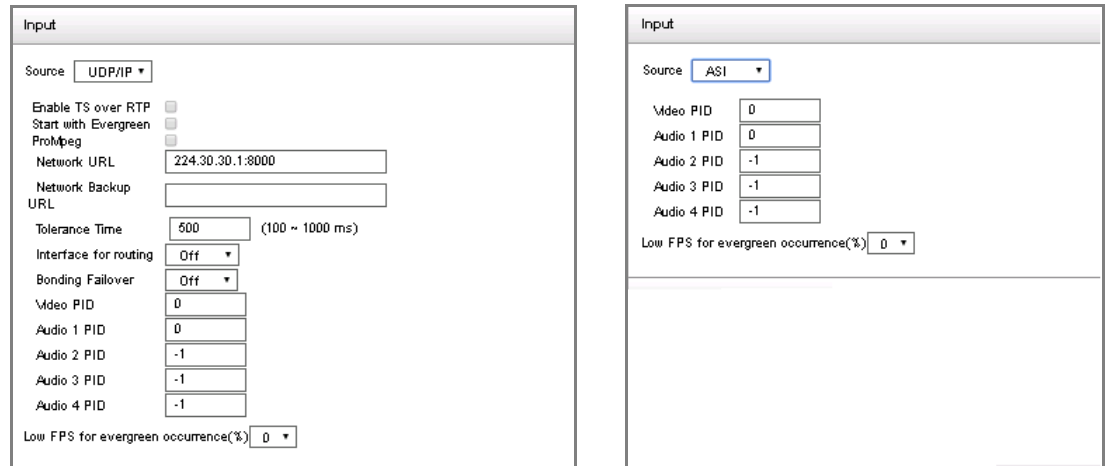



Figure 5.23 Input Settings – UDP/IP (Left) and ASI (Right)

- **Source** – Select the appropriate source type. The input options change according to the type of selected source.
 - SSM Multicast.
 - UDP/IP (Transport Stream).
 - ASI (Transport Stream).
- **Network URL** – The IP address and port for the multicast feed, e.g. 224.10.10.1:8000
- **Video PID** – Video Program ID selection for Multi-program Transport Streams. Default value is 0 and indicates that the first video PID available will be selected. For hexadecimal notation use “0x” prefix, e.g. 0x0203. This option applies to UDP/IP and ASI sources. For radio (or audio-only) channels, a value of “-1” is expected for the Video PID.
- **Audio PID** – Audio Program ID selection for Multi-program Transport Streams. This option applies to UDP/IP and ASI sources. Default value is 0 and indicates that the first video PID available will be selected. A value of “-1” indicate that no audio is desired. For hexadecimal notation use “0x” prefix, e.g. 0x0205.
- **Start with Evergreen** – (only available on UDP/IP inputs) Dictates whether the channel is allowed to start even when no input is available. When enabled, the channel will start but output the Evergreen (still) image if the source is not available. The channel will switch back to the live feed (automatically or manually, depending on the Device setting, see 4.3.6.2) once the live feed becomes available.
- **Runtime source replacement** – This switch enables for the source feed to be changed while the channel is in operation. (**More options missing? Interface for Routine...?**)

Pre-processing

The **Pre-processing** panel enables various pre-processing settings to be configured.



Pre-processing

Reset to default

Master gain (dB) (-60 ~ +10dB)

Audio delay (ms) (-600 ~ +600ms)

Automatic gain control

Figure 5.24 Pre-processing Settings

- **Reset to default** – Button to reset brightness, contrast, saturation and gamma correction to default values. *(Is this correct – brightness, contrast, saturation and gamma have, seemingly, been removed from this dialog?)*.
- **Master gain (dB)** – Audio level is shown in dBs and can be adjusted either upwards (positive dBs, up to +10.0 dBs) or downwards (negative dBs, down to -90 dBs). Extreme dB values (above 300% or 4.8 dBs) may cause distortion. Refer to the table below to convert dBs to % and backwards.

Table 5.1 Reference dB Conversion Table

% to dBs		dBs to %	
% of source	dBs	dBs	% of source
10	-10.0	-10	10
20	-7.0	-9	13
30	-5.2	-8	16
40	-4.0	-7	20
50	-3.0	-6	25
60	-2.2	-5	32
70	-1.5	-4	40
80	-1.0	-3	50
90	-0.5	-2	63
100	0.0	-1	79
110	0.4	0	100
120	0.8	1	126
150	1.8	2	158
170	2.3	3	200
200	3.0	4	251
250	4.0	5	316

% to dBs		dBs to %	
% of source	dBs	dBs	% of source
300	4.8	6	398
400	6.0	7	501
500	7.0	8	631
600	7.8	9	794
700	8.5	10	1000
800	9.0		
900	9.5		
1000	10.0		

- **Audio delay (ms)** – Allows for adjusting audio/video sync by a constant offset, ranging from -600 to +600 ms. This option only applies to MPEG-TS outputs.
- **Automatic gain control** – Normalization and Dynamic Range Compression tools are provided to allow for automatic control of the input audio level. Those help comply with North America or EU regulatory acts (e.g. CALM Act in USA/Canada).

Logo/Overlay

The **Logo/Overlay** configuration enables for up to 4 layers of overlays to be configured. Each layer can be configured individually for positioning, scaling and opacity. Positioning is configured as an offset from the top left corner and scaling is based on percentage of the source image. Alpha channel is also supported for PNG 32-bit images.

Note: The logo/overlay images need to be first uploaded using the **Source Replacement** dialog, and their dimensions need to be a multiple of 16.

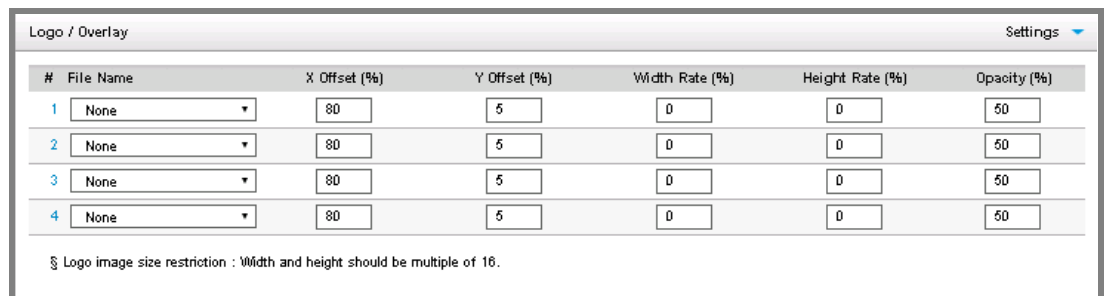

#	File Name	X Offset (%)	Y Offset (%)	Width Rate (%)	Height Rate (%)	Opacity (%)
1	None	80	5	0	0	50
2	None	80	5	0	0	50
3	None	80	5	0	0	50
4	None	80	5	0	0	50

§ Logo image size restriction : Width and height should be multiple of 16.

Figure 5.25 Logo / Overlay Settings

Scrolling Text

Scrolling text may be added and configured in this panel. Control over the font characteristics, margins, scrolling and direction can be specified.

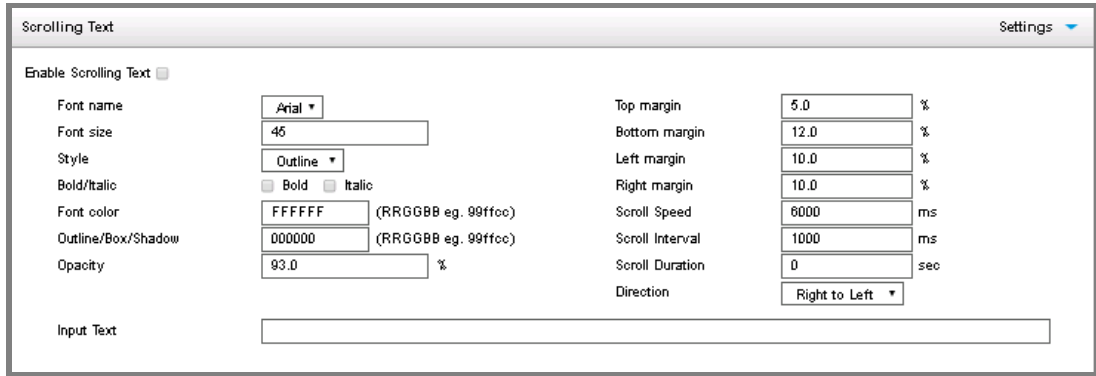

The 'Scrolling Text' settings dialog box includes the following controls:

- Enable Scrolling Text:**
- Font name:** Arial (dropdown)
- Font size:** 46 (text input)
- Style:** Outline (dropdown)
- Bold/Italic:** Bold Italic
- Font color:** FFFFFFFF (text input) (RRGGBB eg. 99ffcc)
- Outline/Box/Shadow:** 000000 (text input) (RRGGBB eg. 99ffcc)
- Opacity:** 93.0 (text input) %
- Top margin:** 5.0 (text input) %
- Bottom margin:** 12.0 (text input) %
- Left margin:** 10.0 (text input) %
- Right margin:** 10.0 (text input) %
- Scroll Speed:** 6000 (text input) ms
- Scroll Interval:** 1000 (text input) ms
- Scroll Duration:** 0 (text input) sec
- Direction:** Right to Left (dropdown)
- Input Text:** (text input)

Figure 5.26 Scrolling Text Settings

Output

The bottom part of the Channel detail page displays the currently configured outputs and their respective Audio and Video Presets. Clicking directly on a preset link brings up the configuration options of the preset. Use the **Add Output** button to create an additional Output or click anywhere on the row (or the pencil icon in the front) of an existing Output to edit it.



Edit	#	Video Preset	Audio Preset	Output	Use
	1	Service	p.c.m	Port 1	<input checked="" type="checkbox"/>

Add Output

Figure 5.27 Output Settings

The Output detail page provides the means to combine an Audio and a Video Preset along with streaming or file output parameters.

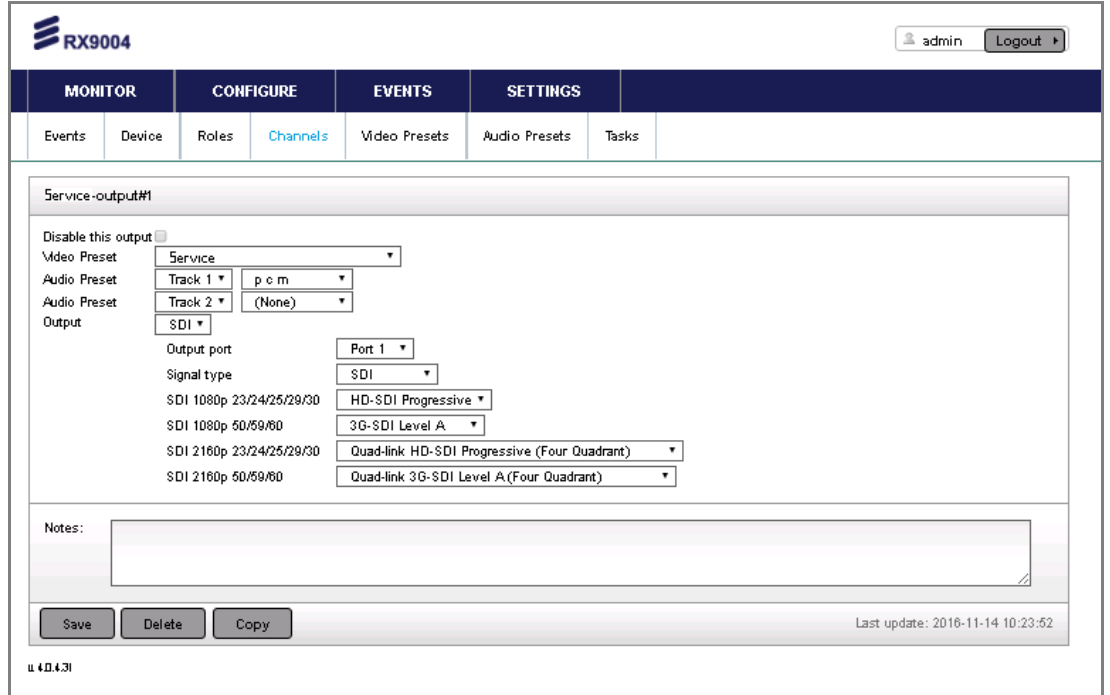

Figure 5.28 CONFIGURE > Channels (Output Details) Page

The title of the page indicates the Channel and the Output number currently being edited. The Video and Audio Preset selection boxes correspond to the available Presets in the database. Different options may be displayed depending up on the delivery mechanism used.

Buttons

- **Save** – This button enables the channel settings to be stored.
- **Delete** – This button enables the selected channel to be deleted.
- **Copy** – This button enables a copy of the channel settings to be created, which permits variants to be created quickly and renamed rather than creating a new channel from scratch.
- **Export** – Exports the channel configuration into XML. The XML file can be loaded directly on transcoding devices.

5.3.5

Video Presets

The **Video Presets** page enables a collection of video decoding parameters to be named and applied to channel outputs. The page displays a list of the pre-configured video presets with details about their respective settings.

Free Text Search:

Name	Codec	Resolution	Frame Rate	Bit Rate	I-Frame Int	Notes
Atomo_60Mbps	Uncompressed	0 X 0	source	2000 Kbps	30	
Atomo80Mbps Capture	Uncompressed	0 X 0	source	2000 Kbps	30	
A/P-59.94	Uncompressed	0 X 0	source	2000 Kbps	30	
ChanItv-59.94	Uncompressed	0 X 0	source	2000 Kbps	30	
HEVC 4K Decoder 50	Uncompressed	0 X 0	source	2000 Kbps	30	
Masters_Envivio_65Mbps_autoGOP	Uncompressed	0 X 0	source	2000 Kbps	30	

6 entries

ii 4.0.4.31

Figure 5.29 CONFIGURE > Video Presets Page

Video presets can be edited by clicking on the corresponding row. New ones can be added by clicking the **Add** button at the bottom of the page.

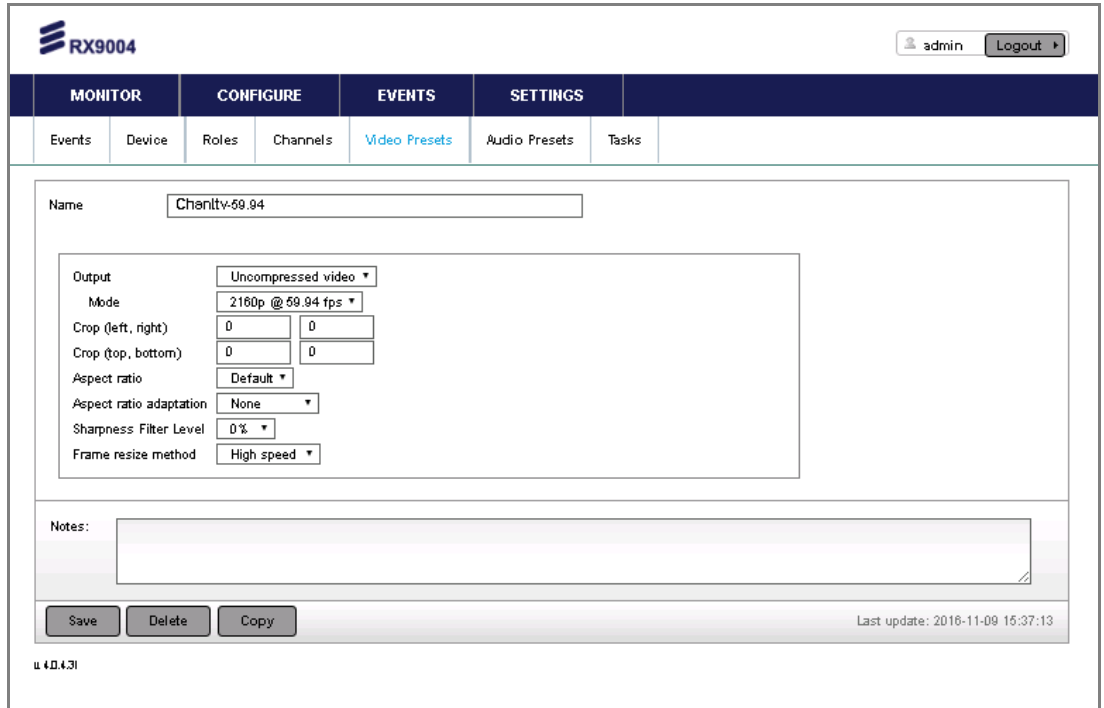

Figure 5.30 CONFIGURE > Video Presets (Detail) Page

This screen provides the following features, depending on the type of video preset selected:

- **Name** – A name to uniquely identify the preset.
- **Output** – Select either “Uncompressed Video” or “No Video” (for audio only outputs).
- **Mode** – The video resolution of the output stream. The following options are available:
 - 3840 x 2160 progressive 60 fps
 - 3840 x 2160 progressive 50 fps
 - 3840 x 2160 progressive 29.97 fps
 - 3840 x 2160 progressive 25 fps
 - 1920 x 1080 interlaced 30 fps
 - 1920 x 1080 interlaced 29.97 fps
 - 1920 x 1080 interlaced 25 fps
 - 1280 x 720 progressive 60 fps
 - 1280 x 720 progressive 59.94 fps
 - 1280 x 720 progressive 50 fps
 - 720 x 576 interlaced 25fps (PAL)

- 720 x 480 interlaced 29.97 fps (NTSC)

- **Crop** – Specifies the rectangle/window to be cropped. Refer to the schematic below for more information. All values are in pixels and refer to the source frame, only positive integers are valid.

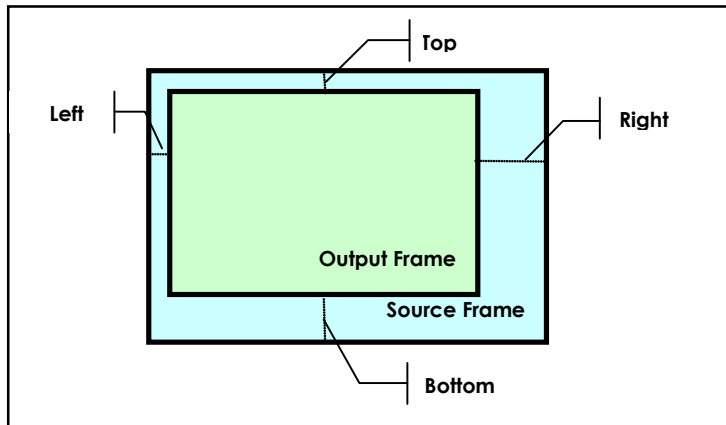

Figure 5.31 Video Presets Crop Window

- **Aspect Ratio** – Controls the aspect ratio setting in the video header information. For RTSP-based output, since the connection is set up once, any on-the-fly aspect ratio changes in the source are not propagated to the output. Four options are available:
 - Default (Square pixel)
 - 4:3
 - 16:9
 - Source (Follows source a/r)
 - **Aspect Ratio Adaptation** – This option allows for the adaptation of the video frame to different aspect ratios. Three options are available:
 - **None** – No adaptation is performed.
 - **Letter/Pillar boxing** – Vertical or horizontal black bars are added in order to preserve the selected aspect ratio.
 - **Pan & Scan** – The content is cropped horizontally or vertically in order to preserve the selected aspect ratio.
- Note:** For more details on the aspect ratio configuration options, please refer to *Appendix F, Aspect Ratio Adaptation*.
- **Sharpness Filter Level** – Controls the level of sharpness/smoothness of the output frame.
 - **Frame Resize Method** – Controls the speed and effectiveness of frame resizing.
 - **Notes** – This field is reserved for user notes or comments.

- **Save** – This button enables the preset settings to be stored.
- **Delete** – This button enables the selected preset to be deleted.
- **Copy** – This button enables a copy of the settings to be created, which permits variants to be created quickly and renamed rather than creating a new preset from scratch.

5.3.6 Audio Presets

The **Audio Presets** page enables a collection of audio decoding parameters to be named and applied to channel outputs. The page displays a list of the pre-configured audio presets with details about their respective settings.

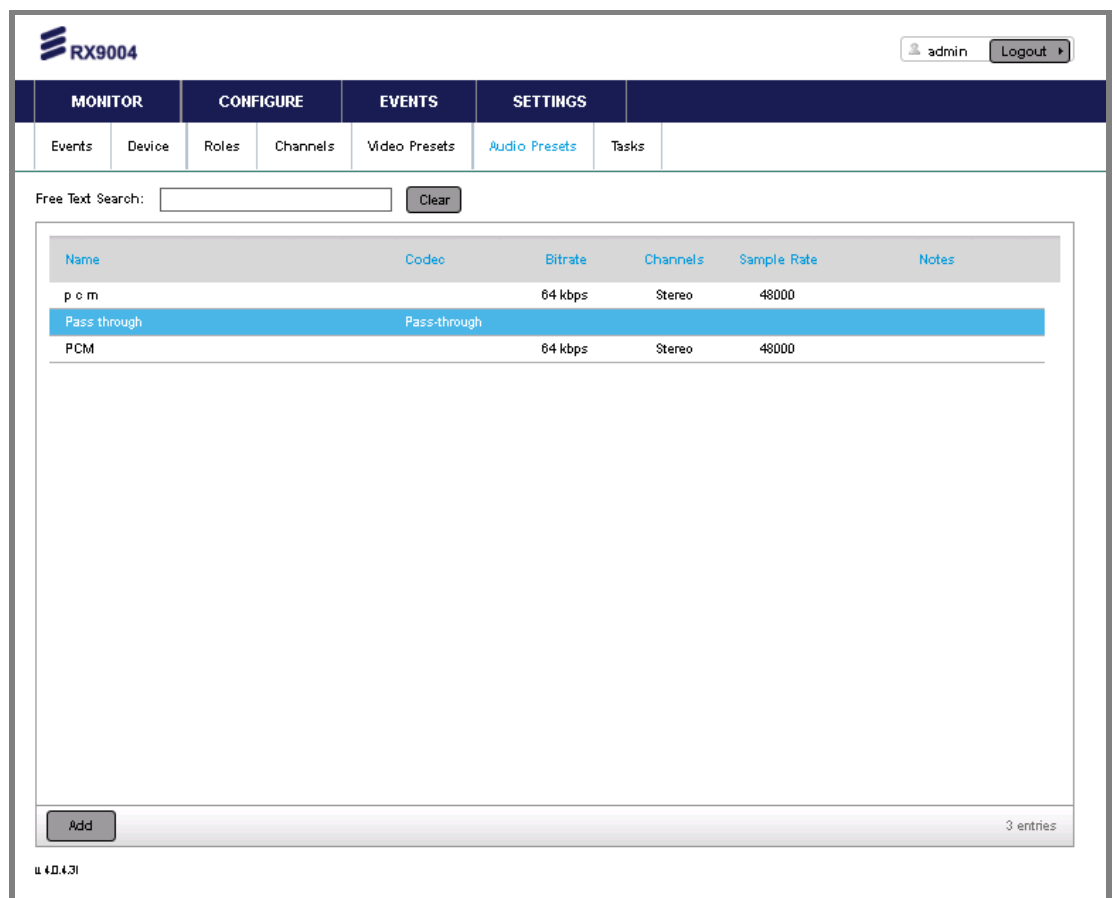

Figure 5.32 CONFIGURE > Audio Presets Page

Audio presets can be edited by clicking on the corresponding row. New presets can be added by clicking the **Add** button at the bottom of the page.

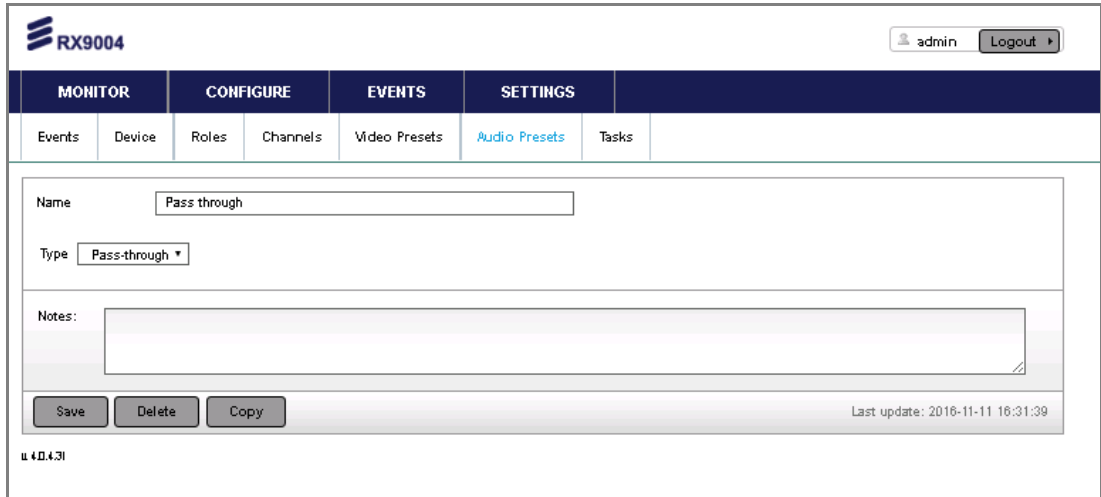

Figure 5.33 CONFIGURE > Audio Presets (Pass-through Detail) Page

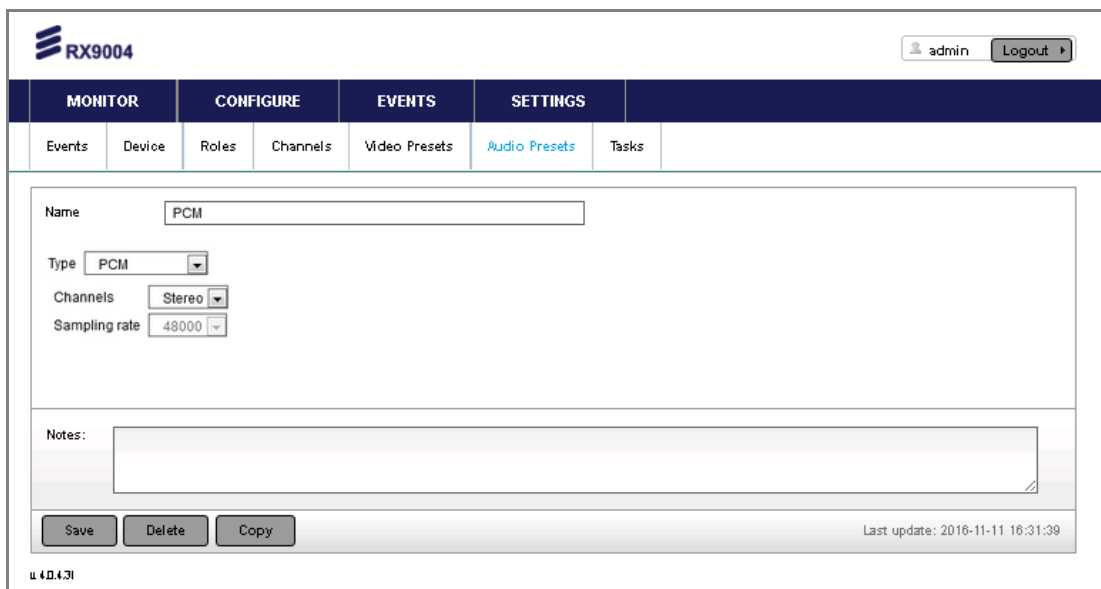

Figure 5.34 CONFIGURE > Audio Presets (PCM Detail) Page

This screen provides the following features, depending on the type of audio preset selected:

- **Name** – A name to uniquely identify the preset.
- **Codec** – Select the appropriate audio encoder module from the list.
- **Channels** – Select the number of audio channels.
- **Sample Rate** – Select the sampling rate of the output audio stream (in Hz).
- **Notes** – This field is reserved for user notes or comments.
- **Save** – This button enables the preset settings to be stored.
- **Delete** – This button enables the selected preset to be deleted.

- **Copy** – This button enables a copy of the settings to be created, which permits variants to be created quickly and renamed rather than creating a new preset from scratch.

5.4 EVENTS Page

The **EVENTS** page provides a log of operational events and alarms.

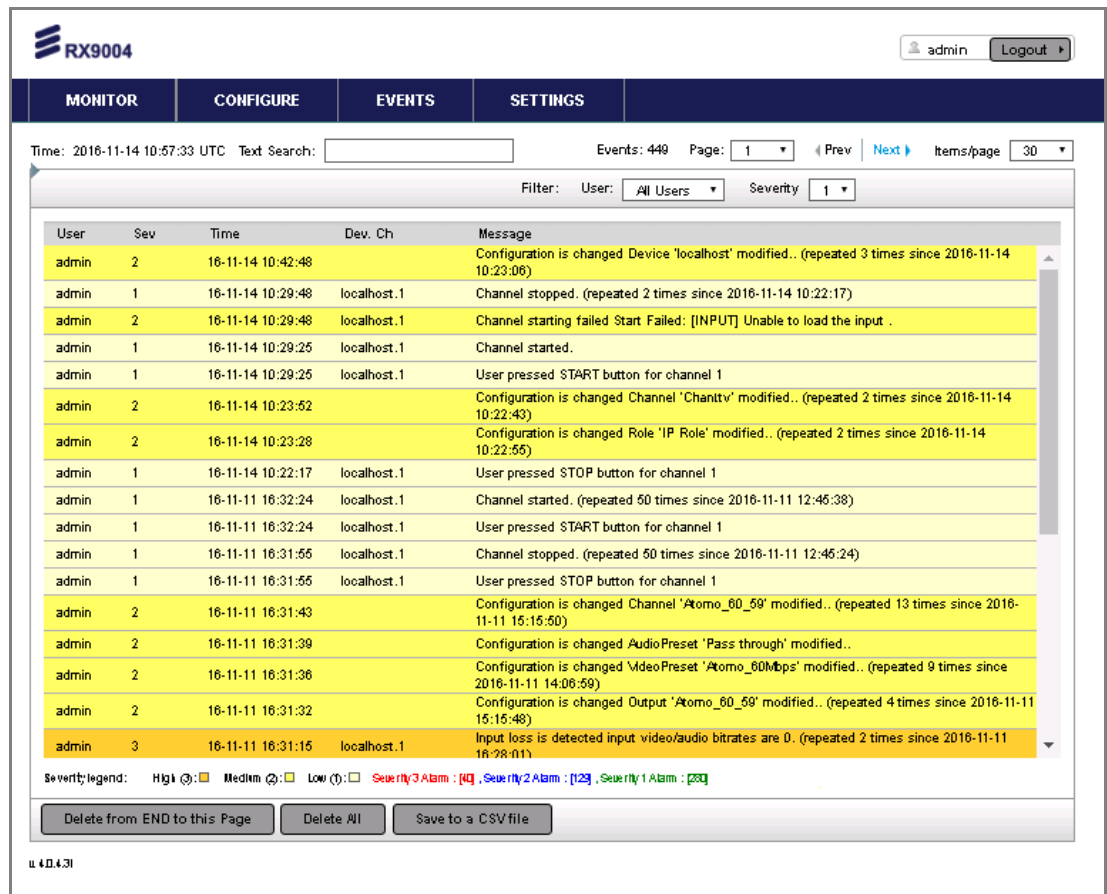

User	Sev	Time	Dev. Ch	Message
admin	2	16-11-14 10:42:48		Configuration is changed Device 'localhost' modified.. (repeated 3 times since 2016-11-14 10:23:06)
admin	1	16-11-14 10:29:48	localhost.1	Channel stopped. (repeated 2 times since 2016-11-14 10:22:17)
admin	2	16-11-14 10:29:48	localhost.1	Channel starting failed Start Failed: [INPUT] Unable to load the input .
admin	1	16-11-14 10:29:25	localhost.1	Channel started.
admin	1	16-11-14 10:29:25	localhost.1	User pressed START button for channel 1
admin	2	16-11-14 10:23:52		Configuration is changed Channel 'Chan1tv' modified.. (repeated 2 times since 2016-11-14 10:22:43)
admin	2	16-11-14 10:23:28		Configuration is changed Role 'IP Role' modified.. (repeated 2 times since 2016-11-14 10:22:55)
admin	1	16-11-14 10:22:17	localhost.1	User pressed STOP button for channel 1
admin	1	16-11-11 16:32:24	localhost.1	Channel started. (repeated 50 times since 2016-11-11 12:46:38)
admin	1	16-11-11 16:32:24	localhost.1	User pressed START button for channel 1
admin	1	16-11-11 16:31:55	localhost.1	Channel stopped. (repeated 50 times since 2016-11-11 12:46:24)
admin	1	16-11-11 16:31:55	localhost.1	User pressed STOP button for channel 1
admin	2	16-11-11 16:31:43		Configuration is changed Channel 'Atom0_60_59' modified.. (repeated 13 times since 2016-11-11 15:15:50)
admin	2	16-11-11 16:31:39		Configuration is changed AudioPreset 'Pass through' modified..
admin	2	16-11-11 16:31:36		Configuration is changed VideoPreset 'Atom0_60Mbps' modified.. (repeated 9 times since 2016-11-11 14:06:59)
admin	2	16-11-11 16:31:32		Configuration is changed Output 'Atom0_60_59' modified.. (repeated 4 times since 2016-11-11 15:15:48)
admin	3	16-11-11 16:31:15	localhost.1	Input loss is detected input video/audio bitrates are 0. (repeated 2 times since 2016-11-11 16:28:01)



Figure 5.35 CONFIGURE > Events Page

Header

At the top, the current time and time zone are displayed; all events are logged based on this time. Dynamic filters allow for **User** and **Severity** filtering for quick information collection and troubleshooting.

Color Coding

Each event/row is color coded based on the severity of the event:

- High (3) – orange background. 
- Medium (2) – dark yellow background. 
- Low (1) – light yellow background. 

- Severity 3 Alarm – **red text**.
- Severity 2 Alarm – **blue text**.
- Severity 1 Alarm – **green text**.

Buttons

At the bottom of the page three buttons are available:

- **Delete from END to this Page** – deletes all old entries of the event log up to the latest ones displayed on the first page.
- **Delete All** – deletes all the entries in the event log.
- **Save to a CSV file** – exports the logs in a CSV file for further analysis and reporting.

5.5 SETTINGS Page

The **SETTINGS** page provides an overview of recent operational events and alarms.

5.5.1 Settings

This setting affects the time stamps of the event entries as well as the triggering of Tasks.

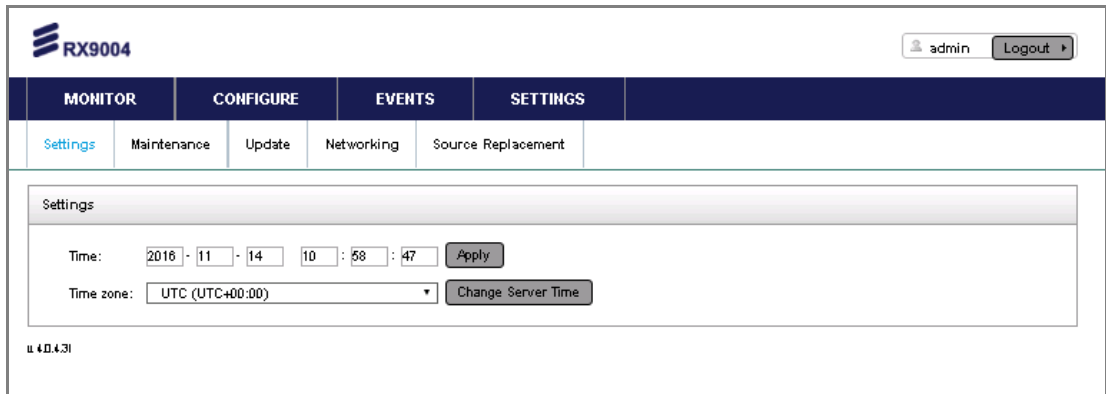

Figure 5.36 *SETTINGS > Settings Page*

Settings

This screen displays the following features:

- **Time** – The time and date fields are displayed and can be edited by typing directly into them. Click the **Apply** button to activate the entered time and date.
- **Time zone** – The time zone can be selected by the drop-down menu. Click the **Change Server Time** button to activate the entered time zone.

5.5.2 Maintenance

This page enables the configuration of the database and management service.

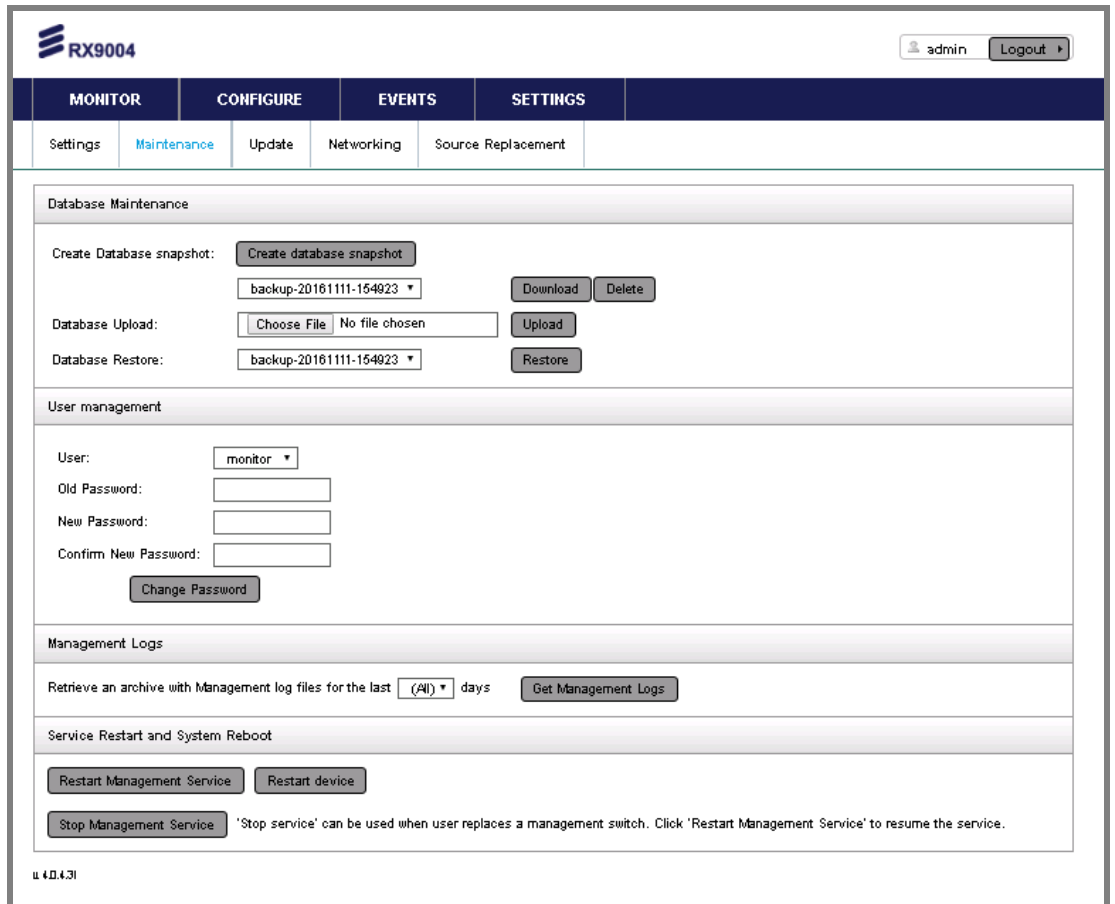

Figure 5.37 SETTINGS > Maintenance Page

Database Maintenance

This tool allows for the maintenance of database that contains all configuration information and Device registrations details.



Figure 5.38 Database Maintenance Settings

This panel displays the following features:

- **Create Database Snapshot** – capture a snapshot of the unit configuration, the newly created snapshot is added in the list of available restore points. The

snapshot/backup is also downloadable in a compressed format (.tar.gz) for off-site storage.

- **Database Upload** – uploads a snapshot of the unit configuration.
- **Database Restore** – to restore a previous backup, select the snapshot date from the combo box and click **Restore**. Alternatively, you can upload a snapshot from your off-line storage and use that one as a restore point. This feature can also be used to migrate configurations between two separate deployments. Make sure both units run the same firmware before attempting to migrate data across them.

Note: Event logs are included into the backup but when restored will not overwrite current log/event entries. All other data will be erased and overwritten once a restore is performed. It is a good practice to obtain a snapshot before restoring to an older snapshot.

User Management

This option is used to change the password for the built-in users. Changes are effective immediately and users logged in after the changes are expected to use the new password. Already logged in users will not be disconnected.



Figure 5.39 User Management Settings

This panel displays the following features:

- **User** – enables selection of the user type.
- **Old Password** – Enter the current password for the user account.
- **New Password** – Enter the new password to be used for the user account.
- **Confirm New Password** – Re-enter the new password to confirm accuracy of the password entered in the above field.

Note: LDAP-based accounts can only be modified through LDAP client applications.

Management Logs

This option is used to retrieve details logs on management operations. It is used for troubleshooting purposes. Click the **Get Management Logs** button to retrieve the archive.

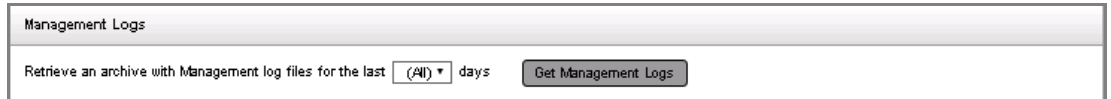

Figure 5.40 Management Logs Settings

Service Restart and System Reboot

This option is used to start and stop the management service and restart the device.

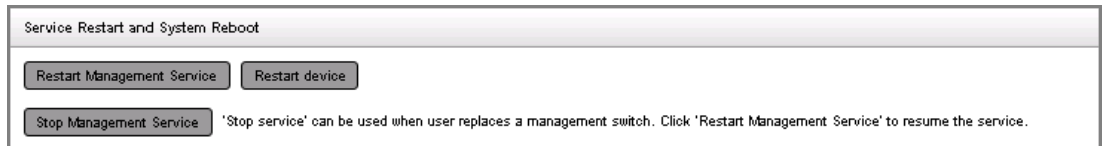

Figure 5.41 Service Restart and System Reboot Settings

This panel displays the following features:

- **Restart Management Service** – restarts the management service application running on the appliance.
- **Restart Device** – re-boots the RX9004 device.
- **Stop Management Service** – stops the the management service application running on the appliance.

5.5.3

Update

This page enables firmware, management system and license updating.

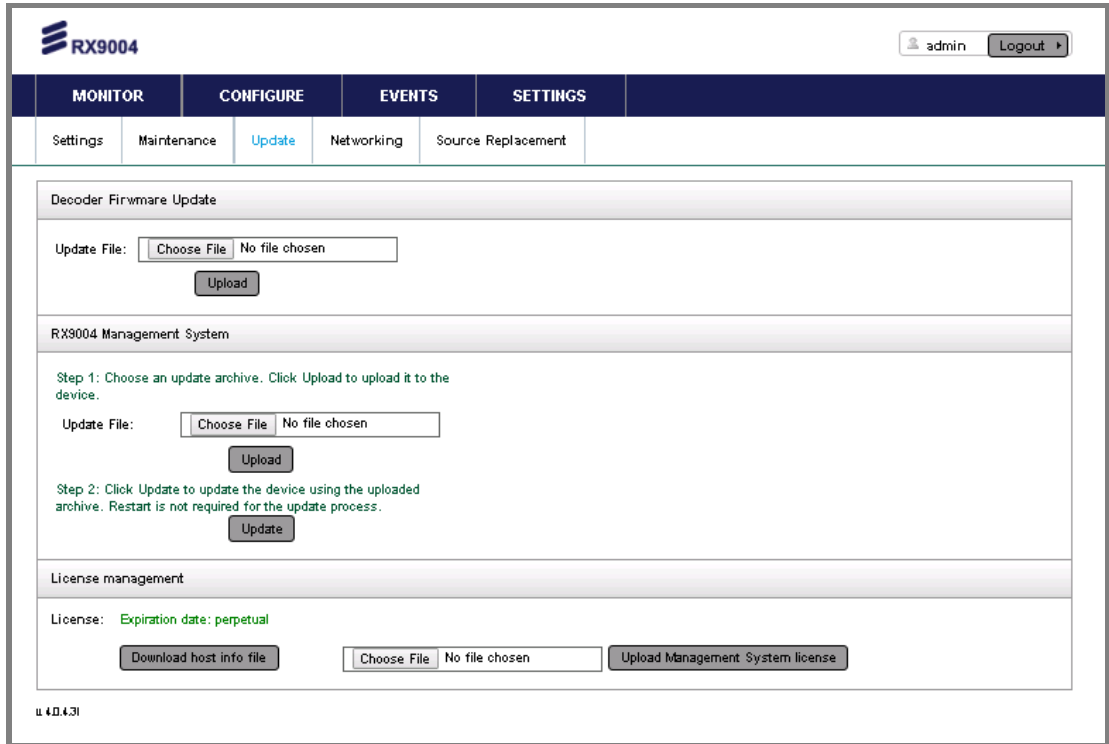

Figure 5.42 SETTINGS > Update Page

Decoder Firmware Update

This tool is used to update the decoding firmware. Contact Ericsson Support to obtain a firmware update along with an MD5 checksum. Always check the validity of the firmware before attempting to upgrade a device.



Figure 5.43 Decoder Firmware Update Settings

Allow time for the operation to complete before navigating away from this page. Due to the size of the binary (~35 MBs) the firmware upload process may take several minutes (especially over slower network connections).

Note: After the firmware is uploaded, use the group or device administration tool to upgrade the network configuration, see section 5.5.4.1 *Networking NIC Tab*.

RX9004 Management System

This tool is used in order to upgrade the firmware. Firmware updates are available only from Ericsson. Contact Ericsson Support to obtain a firmware update along with an MD5 checksum. Always check the validity of the firmware before attempting to upgrade a platform.

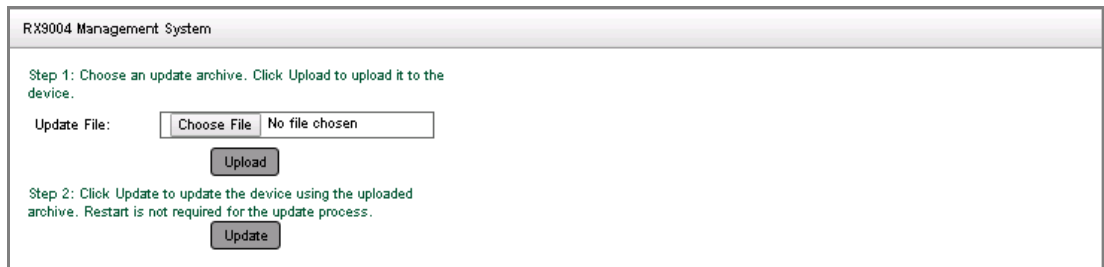

RX9004 Management System

Step 1: Choose an update archive. Click Upload to upload it to the device.

Update File: No file chosen

Step 2: Click Update to update the device using the uploaded archive. Restart is not required for the update process.

Figure 5.44 RX9004 Management System Settings

After uploading is done, press the **Update** button to apply the firmware.

Note: The firmware upgrade process typically takes less than 10 seconds to complete. No system restart/reboot is required unless stated otherwise in the firmware release notes.

License Management

This tool is used to enable new software/firmware functionality. License updates are only available only from Ericsson. Contact Ericsson Support to obtain a license update along with an MD5 checksum. Always check the validity of the license before attempting to upgrade a platform.

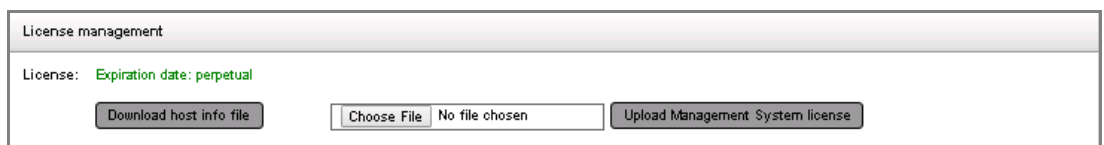

License management

License: Expiration date: perpetual

No file chosen

Figure 5.45 License Management Settings

5.5.4 Networking

The **Networking** tab pages enables configuration of network settings and/or setup additional network interfaces and VLANs.

5.5.4.1 Networking NIC Tab

The **NIC** tab displays the network interface connections that have been set up via the front panel.

Navigate (over HTTP) to the first IP address shown on the Display (e.g. <http://10.0.0.200>). It is recommended that you connect from the same subnet, to avoid any network routing issues.

This tool allows for the network configuration of the HMS appliance through the web-UI. More specifically, it allows for the configuration of the network settings for Ethernet ports, the DNS server(s), default gateway, NTP and SNMP options. Equivalent configuration options are also available through the front panel of the unit, see also *Appendix E, Network Configuration*.

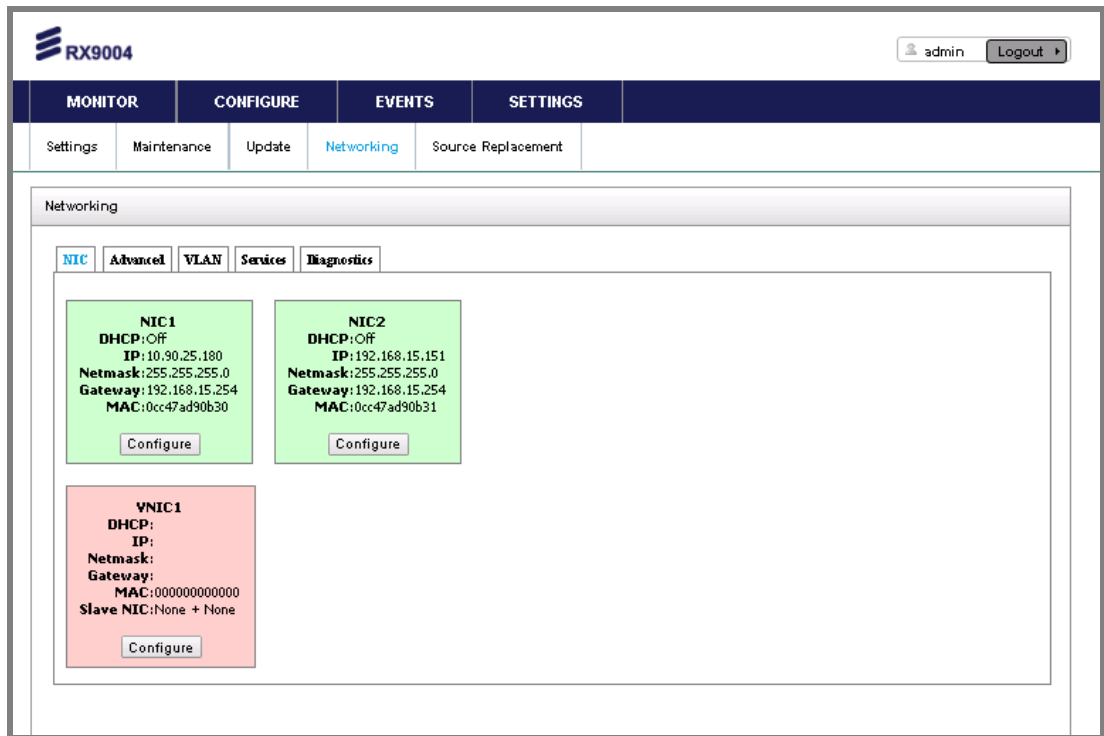

Figure 5.46 SETTINGS > Networking Page

Configured NICs are displayed with a **green** background. Their addresses and settings are displayed in the relevant box. Unconfigured NICs are displayed with a **yellow** background.

Setting up / Modifying NICs

To set up or modify a network interface:

1. Click the corresponding **Configure** button for the NIC to display the settings for the network interface.
2. Enter/modify the settings as required.
3. Click **Save**. The network will restart and apply the changes immediately.

5.5.4.2 Networking Advanced Tab

The **Advanced** tab enables advanced options to be set for the network interfaces.

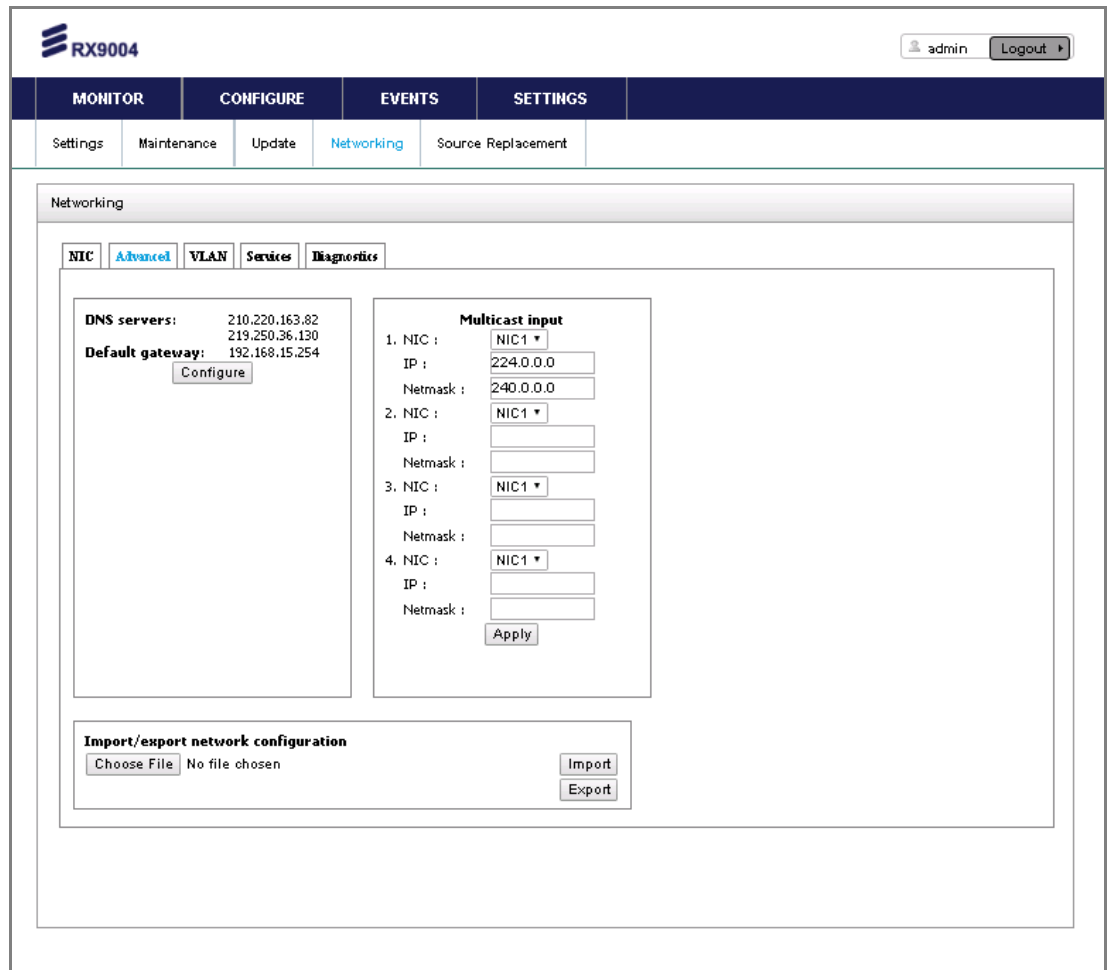

The screenshot shows the RX9004 Web GUI Control interface. At the top, there is a navigation bar with tabs for MONITOR, CONFIGURE, EVENTS, and SETTINGS. Below this, there are sub-tabs for Settings, Maintenance, Update, Networking, and Source Replacement. The main content area is titled 'Networking' and contains several sub-sections: 'NIC', 'Advanced', 'VLAN', 'Services', and 'Diagnostics'. The 'Advanced' tab is selected. The 'Advanced' tab contains three main sections: 'DNS servers', 'Default gateway', and 'Multicast input'. The 'DNS servers' section shows two IP addresses: 210.220.163.82 and 219.250.36.130, with a 'Default gateway' of 192.168.15.254 and a 'Configure' button. The 'Multicast input' section has four entries, each with a 'NIC' dropdown menu (all set to 'NIC1'), an 'IP' field, and a 'Netmask' field. The first entry has IP 224.0.0.0 and Netmask 240.0.0.0. There is an 'Apply' button at the bottom of this section. The 'Import/export network configuration' section at the bottom has a 'Choose File' button, the text 'No file chosen', and 'Import' and 'Export' buttons.

Figure 5.47 SETTINGS > Networking > Advanced Tab Page

This screen displays the following features:

- **DNS Servers** – A comma-delimited list of IP addresses for primary and secondary DNS servers. Click the **Configure** button to set up or modify these settings.
- **Default Gateway** – IP address of the default gateway. Click the **Configure** button to set up or modify these settings.
- **Multicast Input** – Select the network interface where multicast UDP/IP input is provided. Enter the appropriate IP and netmask settings and click the **Apply** button to change the settings.
- **Import/export network configuration** – Click the **Choose File** button to select the network configuration file to be imported/exported. Then click the **Import** or **Export** button, as required, to make the changes. Using this options allows quick configuration of multiple units that are part of the same system.

5.5.4.3 Networking VLAN Tab

The **VLAN** tab enables up to 5 virtual networks to be configured on top of physical and/or virtual network interfaces. A virtual LAN (VLAN) is any broadcast domain that is partitioned and isolated in a computer network at the data link layer (OSI layer 2).

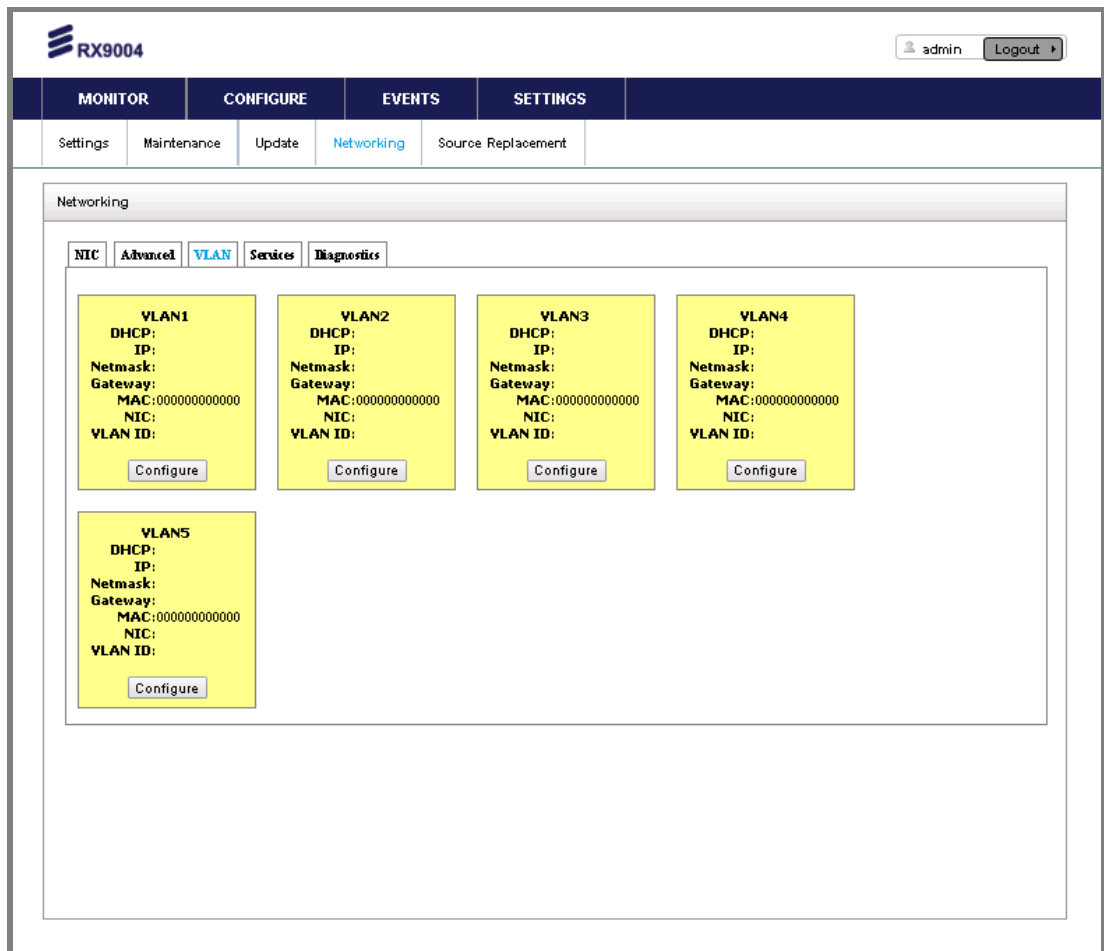

Figure 5.48 SETTINGS > Networking > VLAN Tab Page

VLANs that are already configured are shown in **green**, while empty VLAN slots are in **yellow**. When VLANs are created, they also appear as additional NICs in the NIC tab.

Setting up / Modifying VLANs

To set up or modify a VLAN:

1. Click the corresponding **Configure** button for the VLAN to display the settings for the network interface.
2. Enter/modify the settings as required. If deleting a VLAN, check the **Delete VLAN** box.
3. Click **Save**. The network will restart and apply the changes immediately.

5.5.4.4 Networking Services Tab

The Services tab enables additional parameters such as the SNMP trap sinks and the NTP servers to be configured.

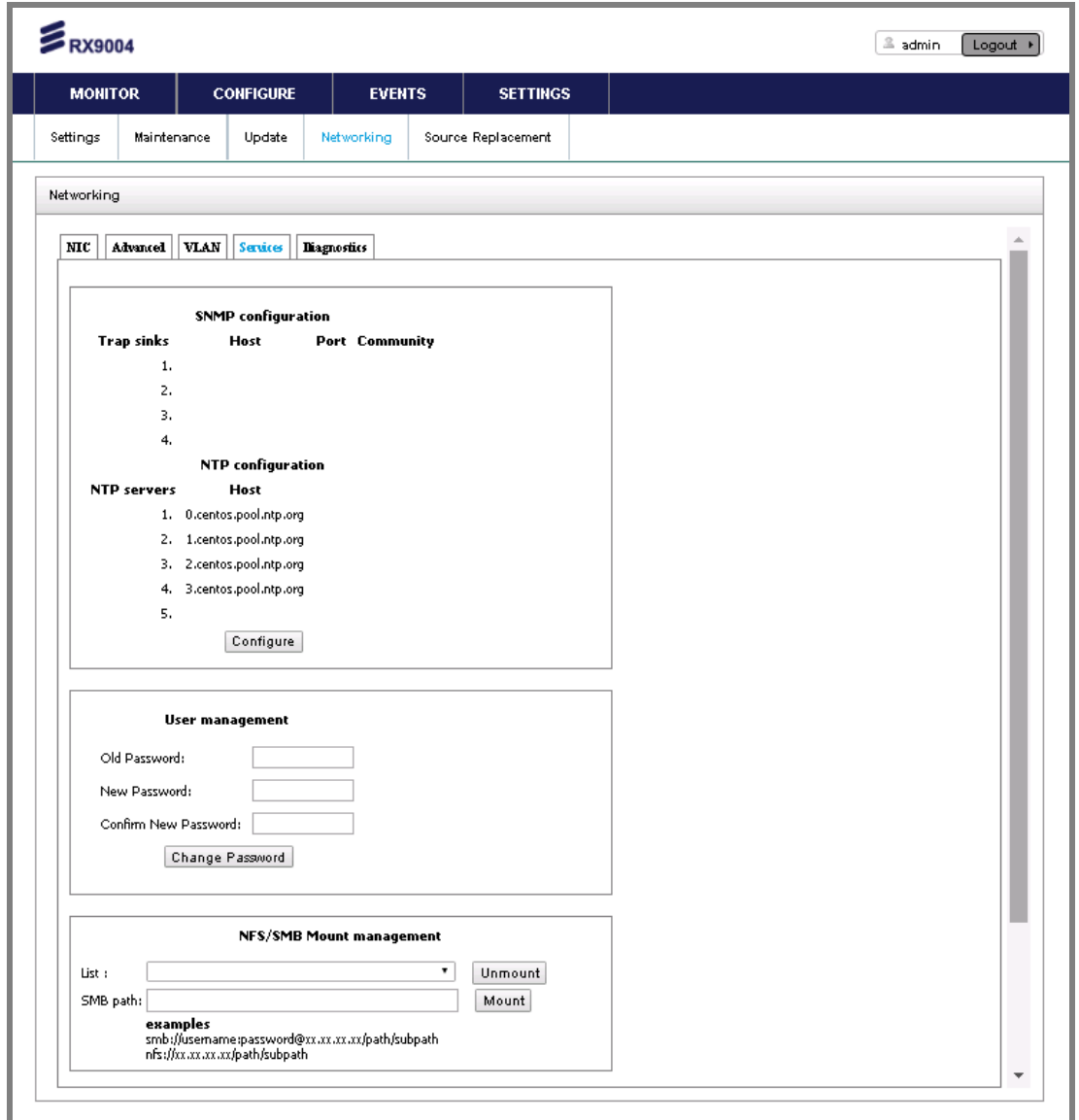

Figure 5.49 SETTINGS > Networking > Services Tab Page

SNMP Configuration / NTP Configuration

This screen displays the following features:

- **Trap Sink Host** – The IP address or DNS name of the host to receive SNMP traps.
- **Trap Sink Port** – The Host’s UDP port where traps are sent; default is 162.
- **Trap Sink Community** – SNMP community identifier; default is "public". This applies for both SNMP traps and SNMP set/get command.

- **NTP Server Host** – IP address or DNS name of a Network Time Protocol server. NTP servers are contacted based on the order they are listed (the topmost one is the primary, etc).

User Management

This screen enables you to change the user password:

- **Old Password** – Enter the current password for the user account.
- **New Password** – Enter the new password to be used for the user account.
- **Confirm New Password** – Re-enter the new password to confirm accuracy of the password entered in the above field.
- **Change Password** – Click this button to change the password, when the old and new passwords have been successfully entered in the above fields.

NFS / SMB Mount Management

This screen enables you to modify the NFS / SMB mount management parameters.

5.5.4.5

Networking Diagnostics Tab

The **Diagnostics** tab enables network configuration errors to be diagnosed and system-level information to be obtained.

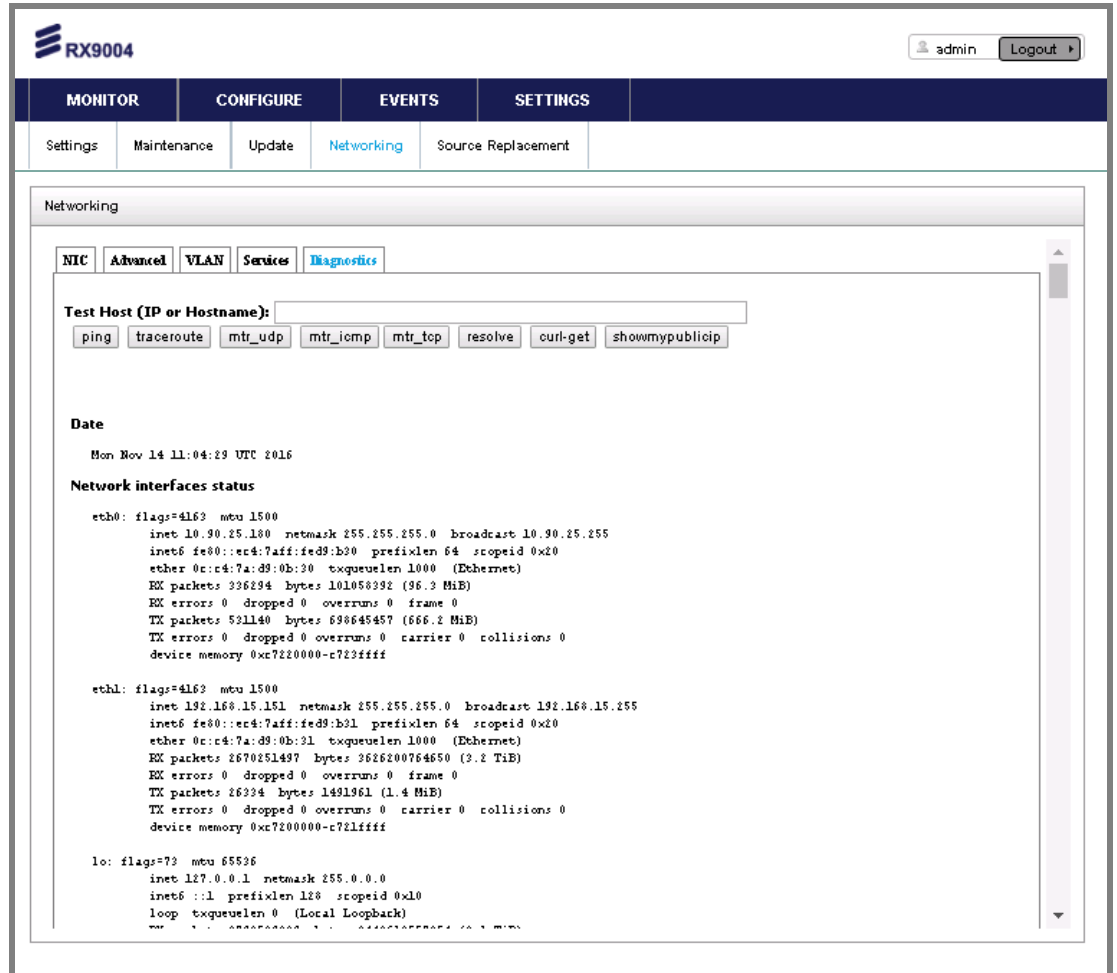

Figure 5.50 SETTINGS > Networking > Diagnostics Tab Page

This screen may display the following:

- **Ping** – Instructs the unit to reach a specific network resource (IP address) over ICMP. Used to test connectivity and latency between RX9004/HMS and the ecosystem.
- **Traceroute** – Instructs the unit to find a specific network resource (IP address) over ICMP and report details about the path utilized. Used to measure transit delays and diagnose and network routing errors.
- **Network Interface Status** – Provides full details about the configuration of each Network Inter-face. Read-only.
- **Routing Table** – Provides full details about the routing configuration on the system. Helps troubleshoot routing errors and multicast/broadcast reception or delivery issues.
- **Link Status** – Reports the status of each network interface.
- **Disk Usage** – Lists the disk utilization and available space for each filesystem currently mounted.

- **System Info** – Provides extensive details for the configuration of the system such as OS, CPU, memory utilization etc.

5.5.5 Source Replacement

The Source Replacement tab specifies what action to take in the event of loss of input.

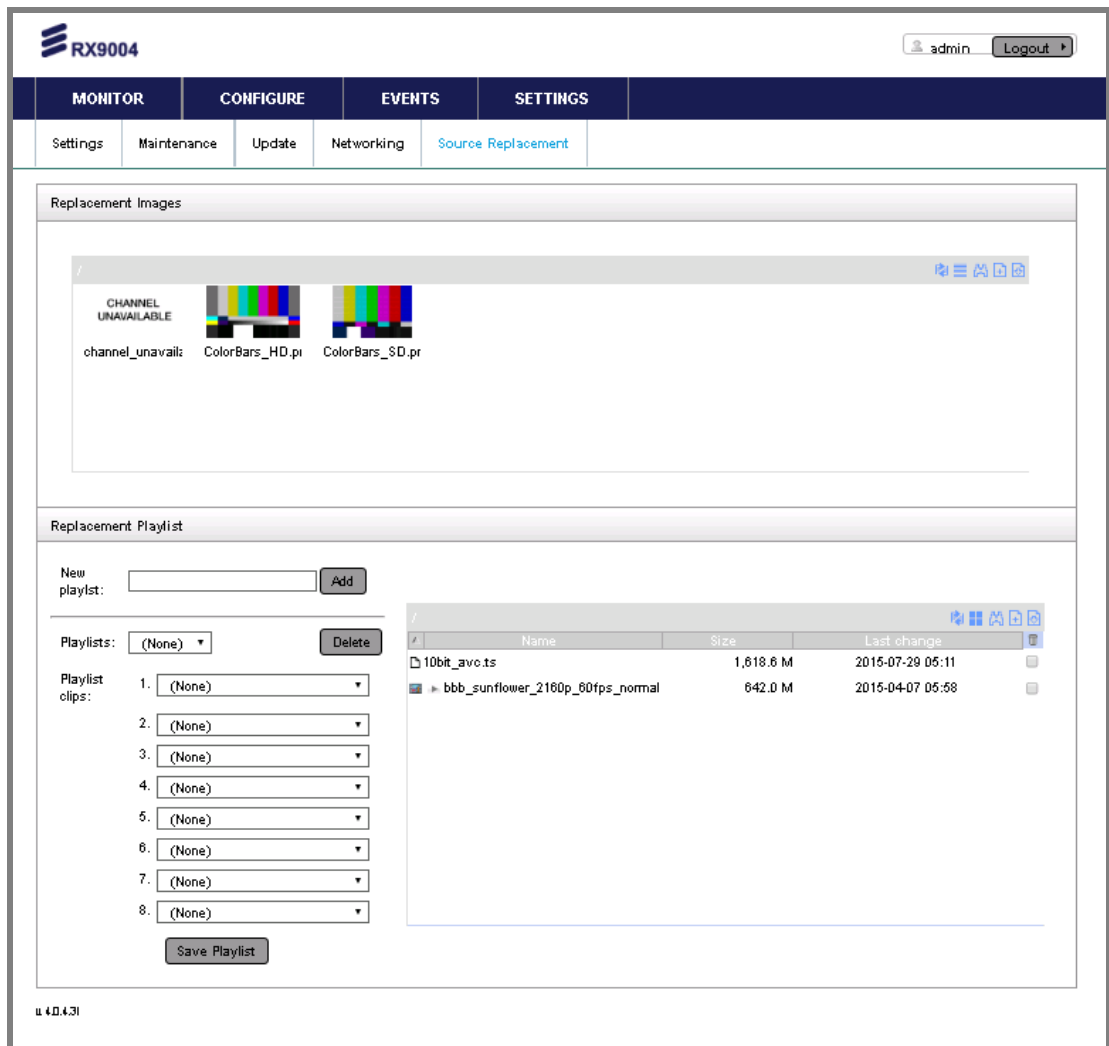

Figure 5.51 SETTINGS > Source Replacement Page

Replacement Images

This tool facilitates the Replace Source Automation presented in *Appendix D, Replace Source Automation*. Use this tool to upload images to be used as source replacement banners or logo overlays.

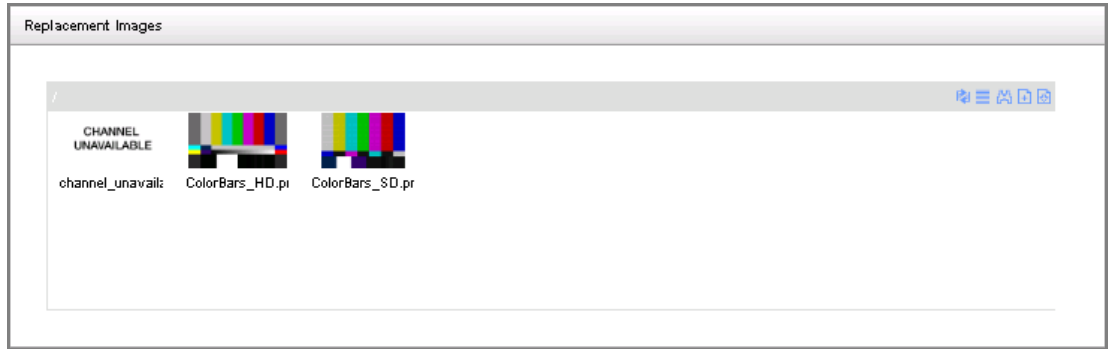

Figure 5.52 Replacement Images Settings

Click the + sign on the top right to upload additional images. A Java plug-in compatible with your web browser is needed to correctly use this page. Supported image files are PNG, BMP, TIFF and JPEG.

Replacement Playlist

This tool facilitates the Playlist Source feature. Use this tool to upload video clips and assemble playlist to be used as source or source replacement on Channels.

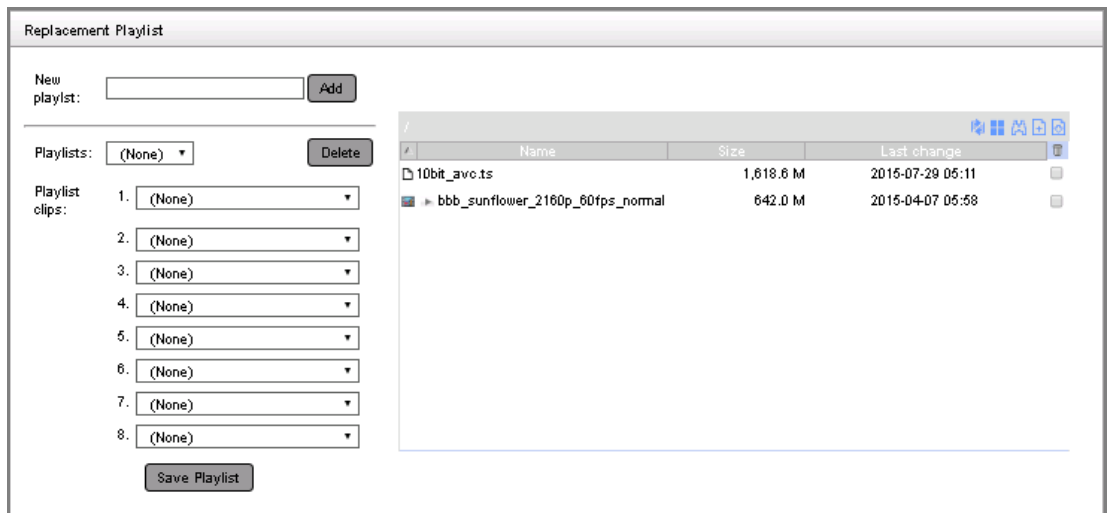

Figure 5.53 Replacement Playlist Settings

Click the + sign on the top right to upload additional clips. A Java plug-in compatible with your web browser is needed to correctly use this page. Supported files are TS, MPG, VOB and MP4.

BLANK



Architecture and Networking

Chapter 6

Contents

6.1	RX9004 Function.....	6-3
6.1.1	Building blocks	6-3
6.2	Introduction to Transport Streams	6-4
6.2.1	IP Encapsulation of MPEG Transport Streams	6-4
6.2.2	Mapping of MPEG-2 TS Packets	6-4
6.2.3	MPEG Layer.....	6-5
6.2.4	RTP Layer	6-5
6.2.5	UDP Layer.....	6-6
6.2.6	IP Layer.....	6-6
6.2.7	Ethernet Layer.....	6-6
6.2.8	IP Overhead	6-6
6.3	Typical Configuration and Restart/Reboot Control	6-7
6.4	Simple Network Management Protocol (SNMP)	6-9
6.4.1	Overview	6-9
6.4.2	HERO Decoder SNMP	6-9
6.4.3	Decoder Traps.....	6-10

List of Figures

Figure 6.1	Internal Hierarchy	6-3
Figure 6.2	Mapping of MPEG-2 TS Packets	6-4
Figure 6.3	Mapping of MPEG-2 TS Packets	6-5
Figure 6.4	Mapping of MPEG-2 TS Packets	6-6
Figure 6.5	HMS Group Configurations (Typical)	6-7
Figure 6.6	Device Management Service (General)	6-8
Figure 6.7	Device Management Service (UHD Decoder).....	6-8
Figure 6.8	SNMP Tree View.....	6-10
Figure 6.9	SNMP Traps.....	6-11

List of Tables

Table 6.1	IP Overhead	6-7
-----------	-------------------	-----



BLANK

6.1 RX9004 Function

Each RX9004 device may run up to 4 Channels simultaneously. Each Channel is fully isolated from the others within the same Device and is managed separately. RX9004 utilizes XML-based configuration files to fully describe the functionality of a Channel.

Each Channel consists of a single input/source and one or more outputs. Further, each output consists of video and audio delivery options and corresponding output configuration options.

The overall hierarchy is illustrated in the diagram below:

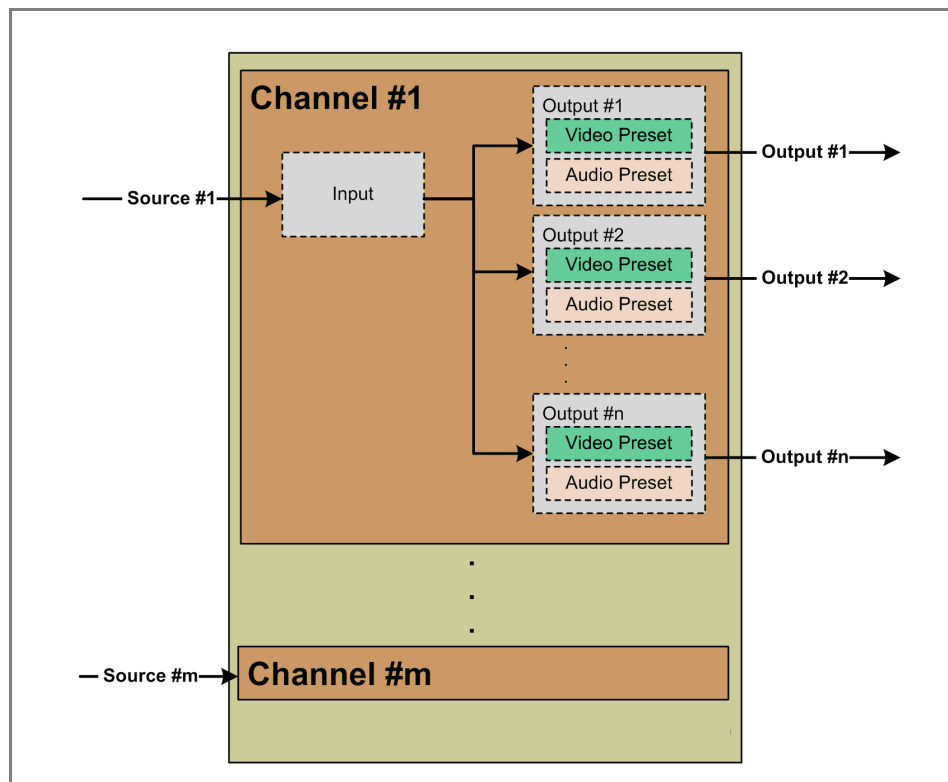

Figure 6.1 Internal Hierarchy

6.1.1 Building blocks

The following building blocks are available:

- **Video Preset** – A collection of video parameters (e.g. resolution, frame rate, crop window, aspect ratio adaptation etc).
- **Audio Preset** – A collection of audio parameters (e.g. number of channels etc).
- **Channel** – A processing task with a single input and one or more outputs. Each output uses a video and an audio preset. Multiple Channels can use the same Audio and/or Video Presets and any change to those presets (e.g. resolution) affects all associated channels automatically.

- **Task** – A scheduled event that performs an action on a Channel. For example, start a Channel at a given date and time.
- **Role** – A collection of Channels. Roles are assigned to Devices to deliver the associated Channels/outputs. A Role can be assigned to several Devices at the same time, while a Device can only have one Role at any given time.
- **Device** – An RX9004 Device. Each Device can process multiple Channels at the same time, as dictated by the Role it is assigned.

6.2 Introduction to Transport Streams

6.2.1 IP Encapsulation of MPEG Transport Streams

An MPEG Transport Stream has the following format.

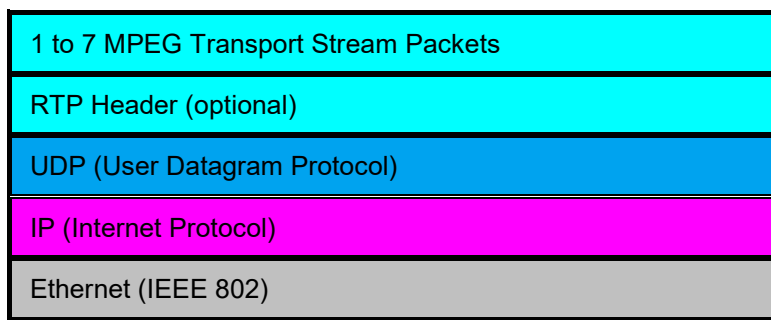

Figure 6.2 Mapping of MPEG-2 TS Packets

Between one and seven MPEG Transport Stream packets are carried in a UDP packet.

The UDP packet may optionally also contain an Real Time Protocol (RTP) header, which adds additional information such as a sequence number and a timestamp, which can help in the detection of packet loss across a network. The RTP header is 12 bytes long.

The UDP header is 8 bytes long.

The network layer protocol is IPV4, which adds a 20 byte header to every packet.

The physical link layer is Ethernet at either 100 Mbps or 1000 Mbps.

6.2.2 Mapping of MPEG-2 TS Packets

The mapping of MPEG-2 TS packets into IP data frames is done according to the protocol stack shown in the following illustration.

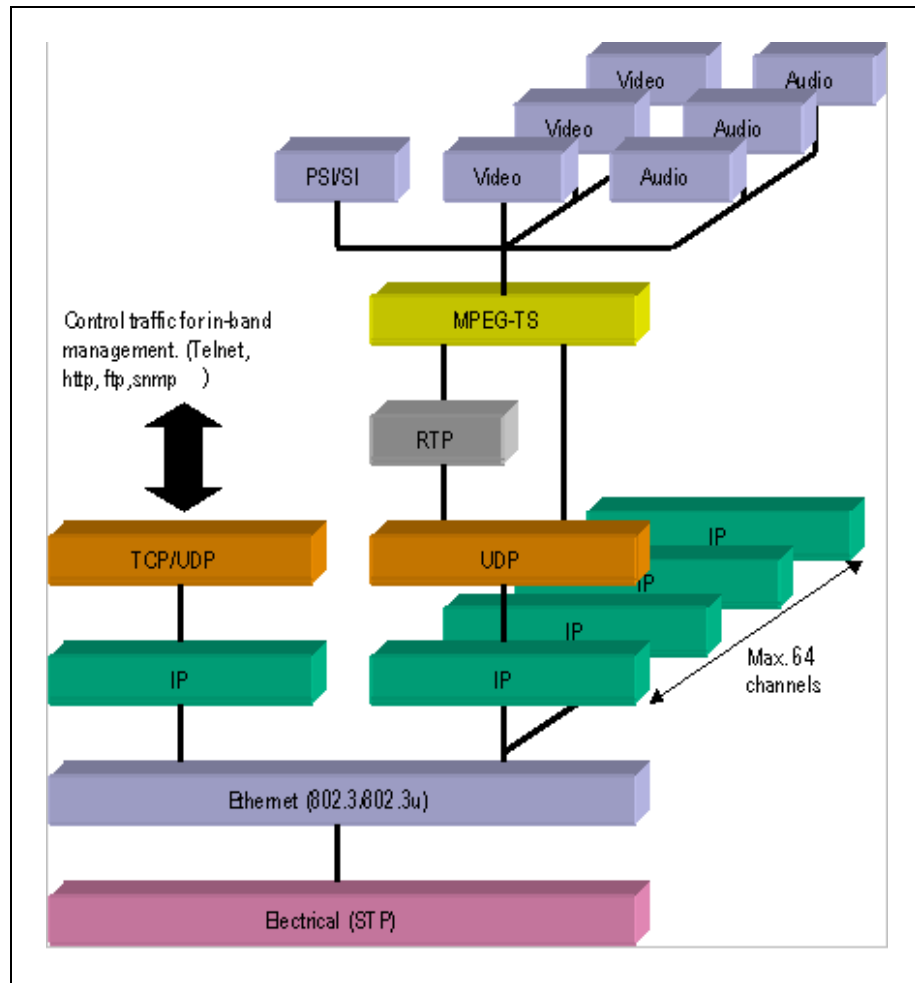

Figure 6.3 Mapping of MPEG-2 TS Packets

6.2.3 MPEG Layer

The MPEG-2/DVB layer is specified in ISO/IEC IS 13818 Generic Coding of Moving Pictures and Associated Audio. The main functionality of this layer is to transform MPTS (Multi-Program Transport Streams) into a number of SPTS (Single-Program Transport Streams). A Transport Stream carrying multiple programs is in this way split into a number of mini Transport Streams, each carrying a single program. This ensures that the video can be passed through limited bandwidth links such as ADSL further down the transmission path.

6.2.4 RTP Layer

The RTP layer is optional, and will add an 8 byte RTP header to the new packet. This header contains a sequence number and a time stamp.

6.2.5 UDP Layer

The UDP layer is according to RFC768 User Datagram Protocol. The user can control the target UDP port number for the MPEG-2 stream. A configurable number of 188 byte long MPEG-2 TS packets are mapped straight into an UDP frame with no additional overhead. The MTU for Ethernet is usually 1500 bytes. This limits the number of MPEG-2 TS packets per UDP frame to lie within 1 to 7. The following illustration shows the mapping of MPEG-2 Transport Streams into UDP packets.

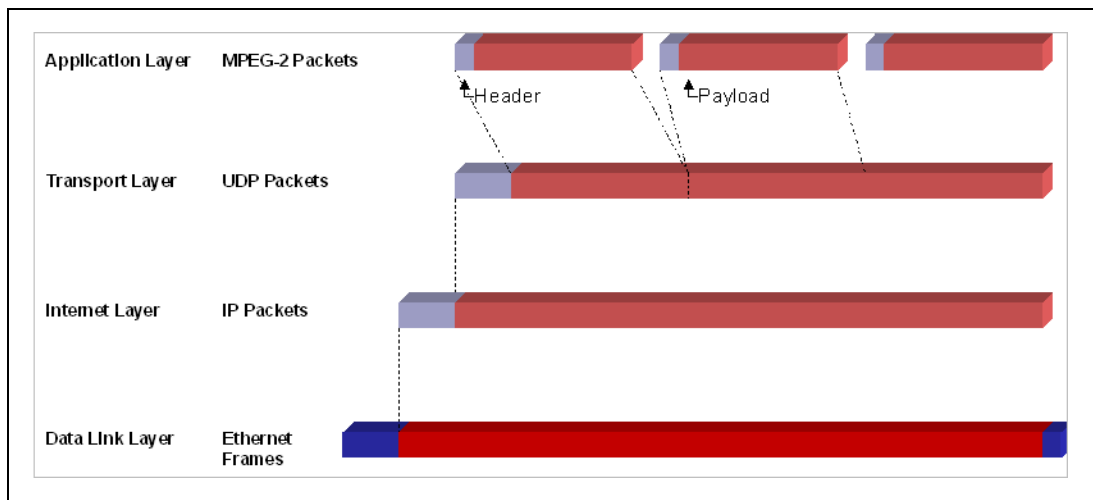

Figure 6.4 Mapping of MPEG-2 TS Packets

6.2.6 IP Layer

The IP layer is according to RFC791 Internet Protocol Specification. The user is allowed access to the following IP header fields: IP source address, IP destination address, Time-To-Live field, Type-Of-Service field. Performing static mapping between class-D IP addresses and the corresponding Ethernet multicast MAC addresses supports limited IP Multicasting (Type 1).

6.2.7 Ethernet Layer

The data link layer is Ethernet according to IEEE 802.3/802.3u (auto sensing 10/100 Mbps, Twisted Pair, RJ-45 connector).

6.2.8 IP Overhead

The IP overhead calculation when mapping MPEG-2 TS packets into IP frames is shown in *Table 6.1*.

Table 6.1 IP Overhead

Item	Overhead factor	Comments
MPEG-2 TS	1.0	
UDP	1324/1316 = 1.006	UDP header=8 bytes
IP	1344/1324 = 1.015	IP header=20 bytes
Ethernet	1358/1344 = 1.010	Eth header=14 bytes

Total overhead factor becomes: $1.006 \times 1.015 \times 1.010 = 1.031$ or 3.1% overhead.

Note: The number of MPEG-2 TS packets one can map down into each UDP frame is variable (between 1 and 7). Usually 7 is used for minimum overhead. This is also used in the above calculation.

6.3 Typical Configuration and Restart/Reboot Control

The figure below depicts typical deployment for a set of encoder/transcoders and management system(s).

The devices can be grouped into multiple groups with different SLA policies and functions - some are for VOD service, some are for live service with higher SLA, and some with lower ones, etc.

The devices are centrally managed by the HMS (HERO Management System) with optional HMS-HA option.

HMS keeps all configurations for the devices, provides starting/stopping channels, status monitoring, reporting, and failover features.

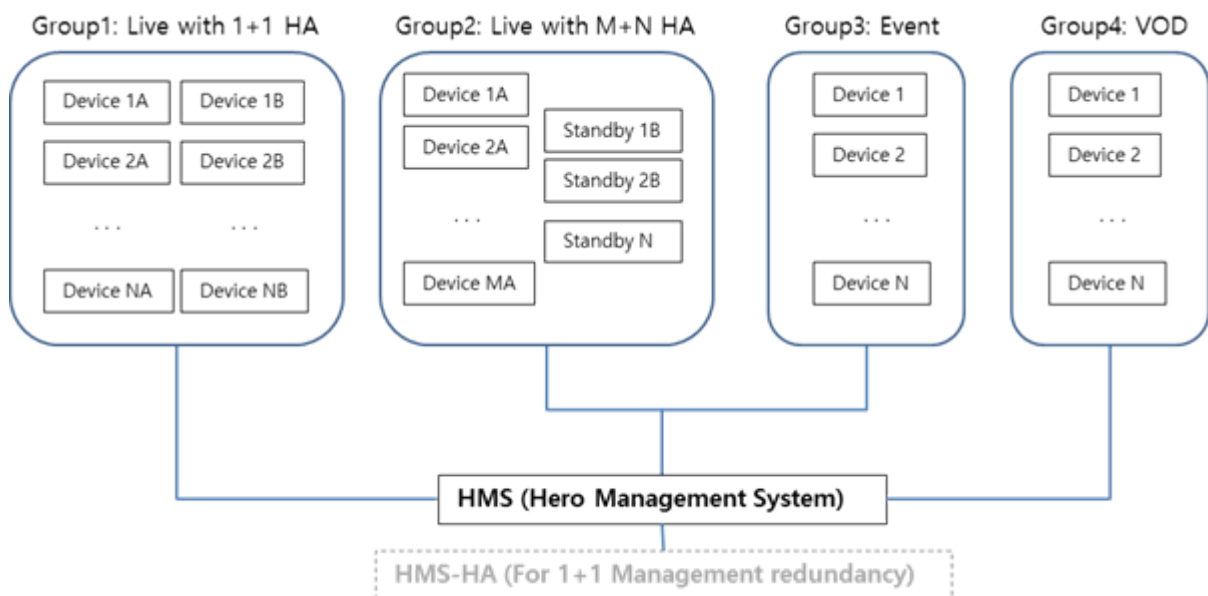

Figure 6.5 HMS Group Configurations (Typical)

Each device has multiple channels with multiple outputs. An internal device level management service communicates with HMS. This management service provides monitoring of channel services and relaunches them if dead, collecting channel and device status information to relay to HMS.

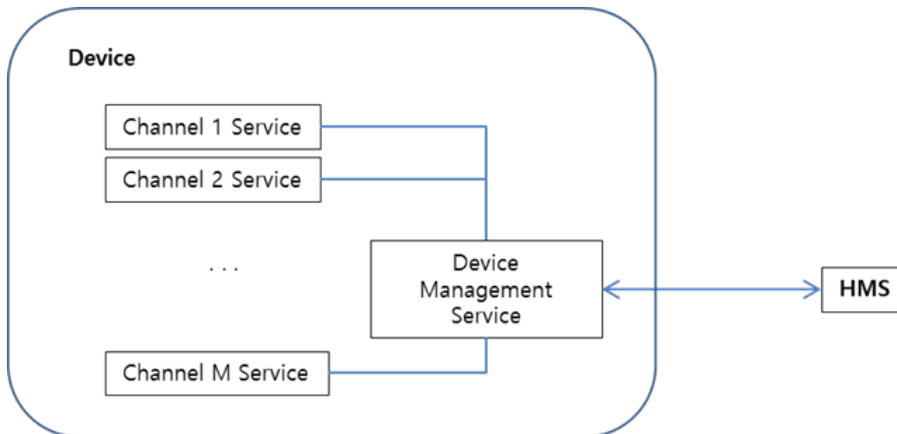

Figure 6.6 Device Management Service (General)

When there is single decoder service (so called, 'device' or 'codec' service) and the HMS as a management service for only 1 device, called HMS-SE (Single Edition).

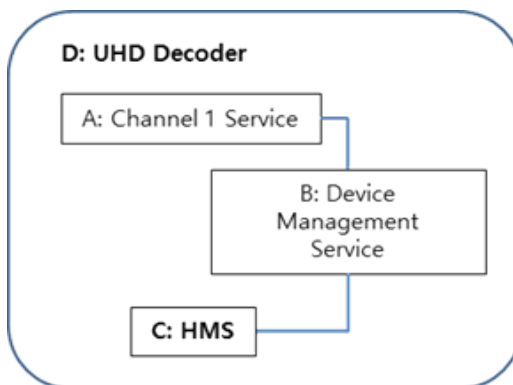

Figure 6.7 Device Management Service (UHD Decoder)

So, by definition:

- **MONITOR > Admin** Device Control: 'Restart Service' - "A" and "B" in the figure above – stopping and rerunning the decoder application and its management program.
- **MONITOR > Admin** Device Control: 'Reboot Device' - "D" in the figure above – rebooting the server hardware
- **SETTINGS > Maintenance** Service Restart and System Reboot: 'Restart device' - "D" in the figure above – rebooting the server (as there are two services in one device)

- **SETTINGS > Maintenance** Service Restart and System Reboot: 'Restart Management Service' - "C" in the figure above – stopping and rerunning the management program.

6.4 Simple Network Management Protocol (SNMP)

6.4.1 Overview

RX9004 configuration and monitoring is done individually for each Device. Additionally, for integration with existing Network Monitoring Systems (NMS) RX9004 exposes a subset of the available information over SNMP. This information, in the form of managed objects, is divided into two categories:

- Generic host resources and network related objects. Resources MIB (defined in RFC 2790) and MIB-2 related MIBs are required.
- Ericsson's specific objects. Private MIBs are required, which can be obtained over HTTP from the RX9004:

`http://<UNIT-IP-ADDRESS>/hms/MEDIAEXCEL-HMS-MIB.mib`

Access to this information can be achieved using any SNMPv2c compatible NMS.

6.4.2 HERO Decoder SNMP

RX9004 Devices provide information and basic remote management capabilities via SNMP. Both monitoring and control are possible through the private MIB, which is included with the RX9004 installation.

A tree view of the SNMP information is shown below.

```

mediaexcel(27593)
|
|--streamInfo(1)
|   |
|   |-- -R-- Integer32 numStreams(1)
|   |
|   |--streamListTable(2)
|   |   |
|   |   |--streamListEntry(1)
|   |   |   |
|   |   |   |   Index: streamListIndex
|   |   |   |   |
|   |   |   |   |-- -R-- Integer32 streamListIndex(1)
|   |   |   |   |   |
|   |   |   |   |   |   Range: 1..6
|   |   |   |   |-- -R-- Integer32 streamIsRunning(2)
|   |   |   |   |-- -R-- Integer32 streamIsActive(3)
|   |   |   |   |-- -R-- String streamXmlName(4)
|   |   |   |   |   |
|   |   |   |   |   |   Size: 0..255
|   |   |   |   |-- -R-- String streamLastError(5)
|   |   |   |   |   |
|   |   |   |   |   |   Size: 0..255
|   |   |   |   |-- -R-- Integer32 streamNumEncoders(6)
|   |   |   |   |-- -R-- Integer32 streamInputFrameRate(7)

```

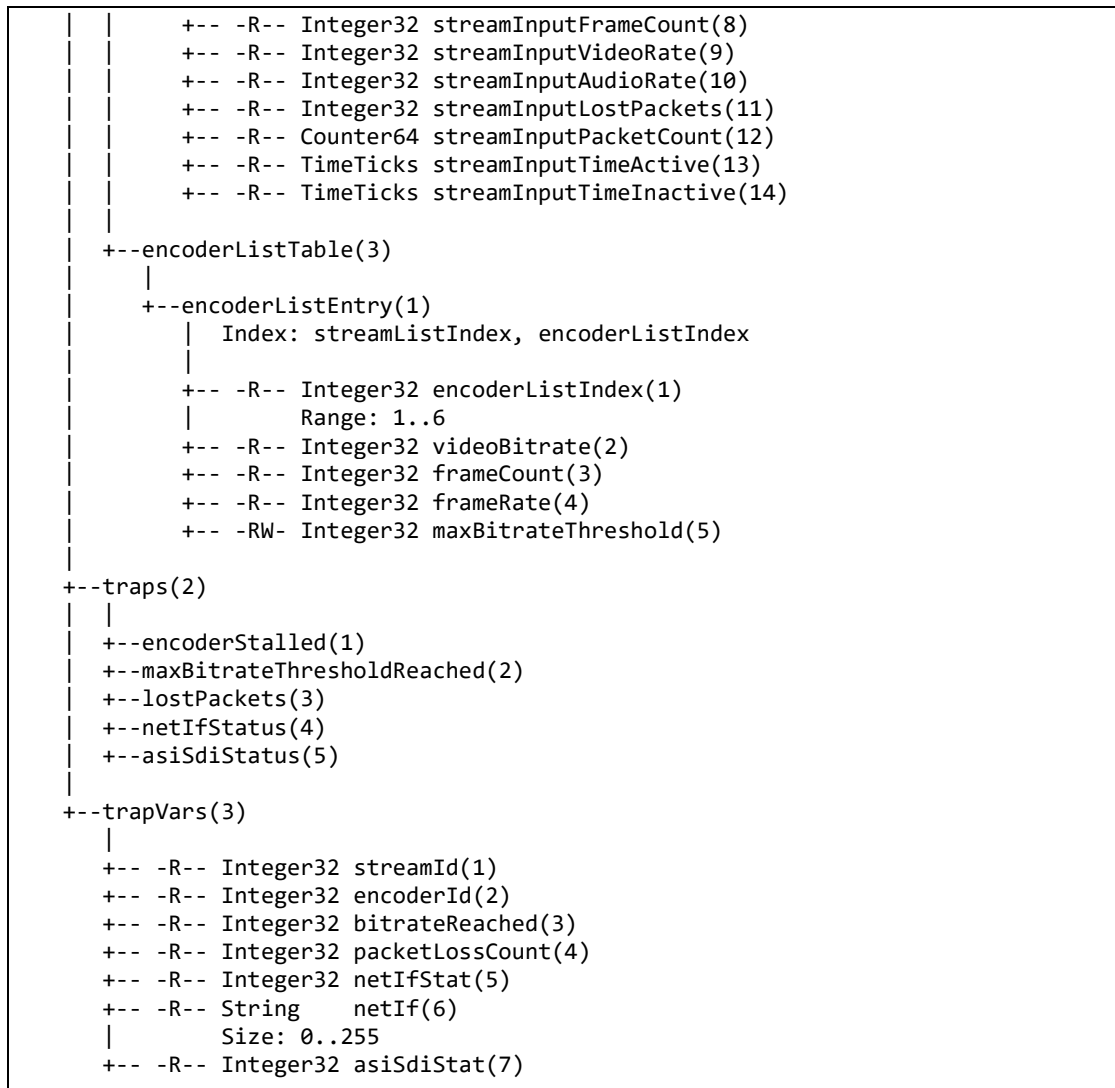

Figure 6.8 SNMP Tree View

6.4.3 Decoder Traps

The following traps can be triggered:

- **maxBitrateThreadoldReached:** Indicates that the encoded stream exceeded the value specified in maxBitrateThreshold.
- **encoderStalled:** Indicates that the Decoder has stopped producing frames. Can be caused by an interruption in the video source.
- **lostPackets:** Indicates that the Decoder is seeing an excessive amount of lost packets in the source feed.
- **netIfStatus:** Indicates an alarm with the network interface(s).
- **asiSdiStatus:** Indicates an alarm with the SDI or ASI signal.

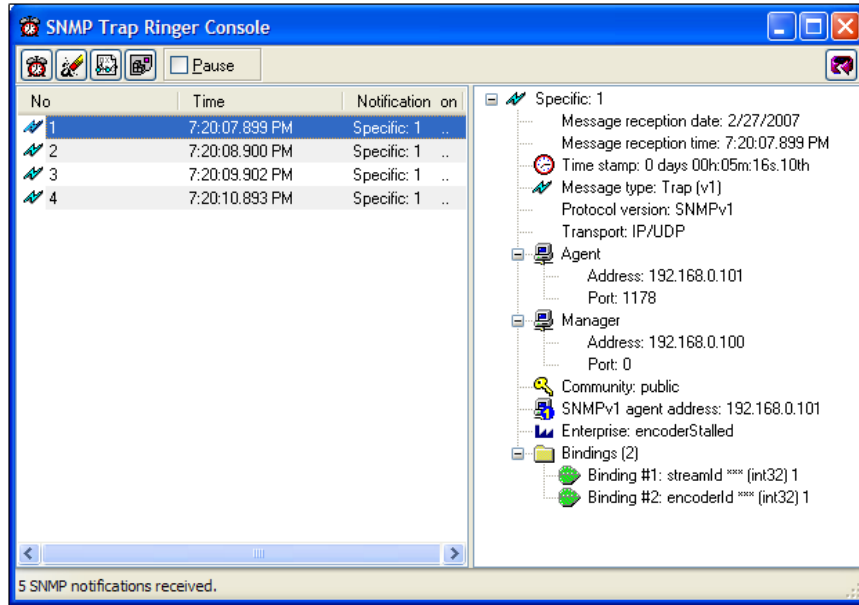

Figure 6.9 SNMP Traps



BLANK



Options, Licensing and Upgrades

Chapter 7

Contents

7.1	Introduction	7-3
7.1.1	Option Cards Available at this Release.....	7-3
7.2	Updating Firmware and Licenses	7-3
7.2.1	Updating the Decoder Firmware	7-3
7.2.2	Updating the Management System.....	7-6
7.2.3	Updating Core Codec License	7-8
7.2.4	Updating Management System License	7-9
7.3	Removal and Replacement of Modules	7-10
7.3.1	Handling Modules.....	7-10
7.3.2	Electrostatic Discharge.....	7-11

List of Figures

Figure 7.1	Decoder Firmware Upload.....	7-4
Figure 7.2	Decoder Firmware Update.....	7-5
Figure 7.3	Confirming the Decoder Firmware Version Number.....	7-5
Figure 7.4	Management System Firmware Upload.....	7-6
Figure 7.5	Management System Firmware Update.....	7-7
Figure 7.6	Confirming the Management System Firmware Version Number.....	7-7
Figure 7.7	Core Codec License Update.....	7-8
Figure 7.8	Management System License Update	7-9
Figure 7.9	Inserting and Withdrawing Modules	7-10

7.1 Introduction

This chapter describes the options that may be used with the RX9004 UHD HEVC Professional Decoder, and the removal and replacement of options. It also describes the procedure for obtaining licenses and how to upgrade your unit.

7.1.1 Option Cards Available at this Release

The chassis cannot be updated in the field. All unit configurations are supplied as is.

7.2 Updating Firmware and Licenses

The functionality of the unit depends on the hardware options fitted and the firmware options installed. Firmware options are enabled or disabled by means of 'license keys'. A license key is a string of numbers which, when downloaded to a unit, will enable a specific feature or feature set.

License keys can be purchased from your local Ericsson sales representative. License keys may be installed by the user, allowing field upgrading of units to be performed simply.

The unit comes with your Option Cards and licenses already installed. However firmware upgrades may be issued from time to time.

Firmware installation/upgrading is performed in two stages as the firmware is supplied in two parts, each performing a separate function:

- Decoder (Device) Firmware
- System Management Firmware

7.2.1 Updating the Decoder Firmware

Decoder firmware files are prefixed with '**hera**'. Updating this firmware is a two stage process: Upload the file then Update (apply) the file.

Firmware updates are only available only from Ericsson. Always check the validity of the firmware before attempting to upgrade a device.

To update the Decoder firmware:

1. Go to the **SETTINGS > Update** page.
2. In the **Decoder Firmware Update** panel, choose the new firmware file by clicking the **Choose File** button and then navigating to the file location.

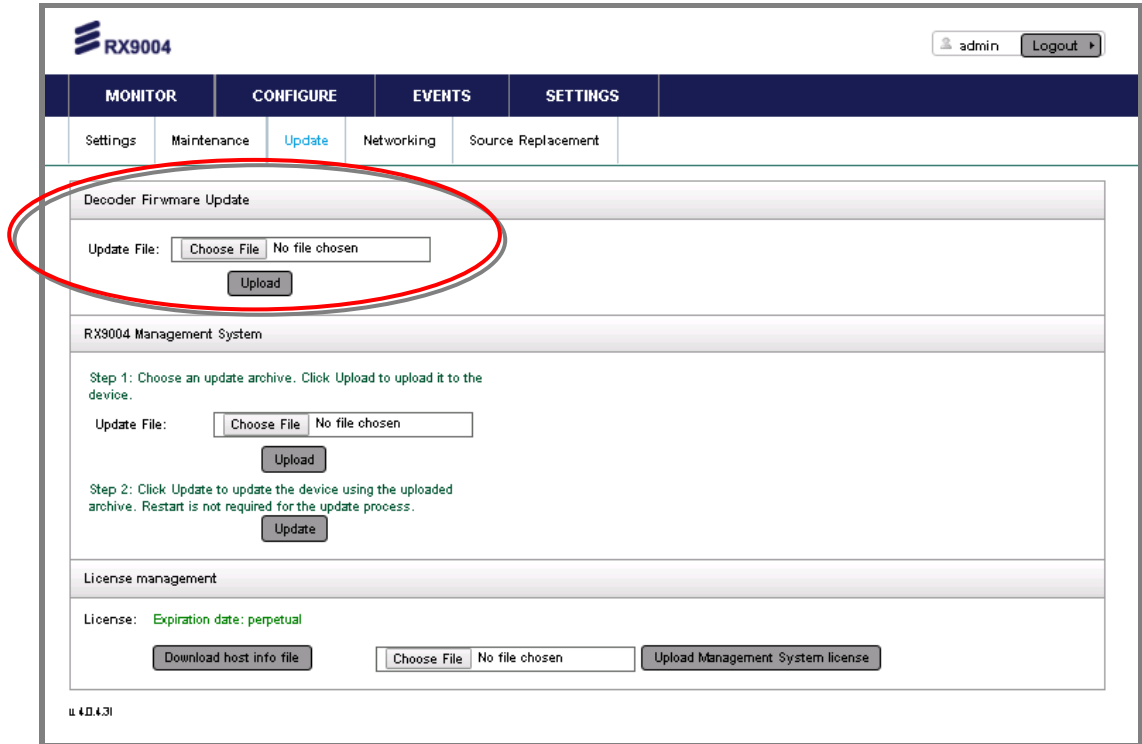

Figure 7.1 Decoder Firmware Upload

3. With the new firmware file selected, and its name displayed in the **Update File** field, click the **Upload** button.

Note: Allow time for the operation to complete before navigating away from this page. Due to the size of the binary (~35 MBs) the firmware upload process may take several minutes (especially over slower network connections).

4. When the firmware is uploaded, go to the **MONITOR > Admin** page to update (apply) the firmware.
5. In the **Device Administration** panel, select the firmware file previously uploaded in the drop-down list and then click the **Update** button.

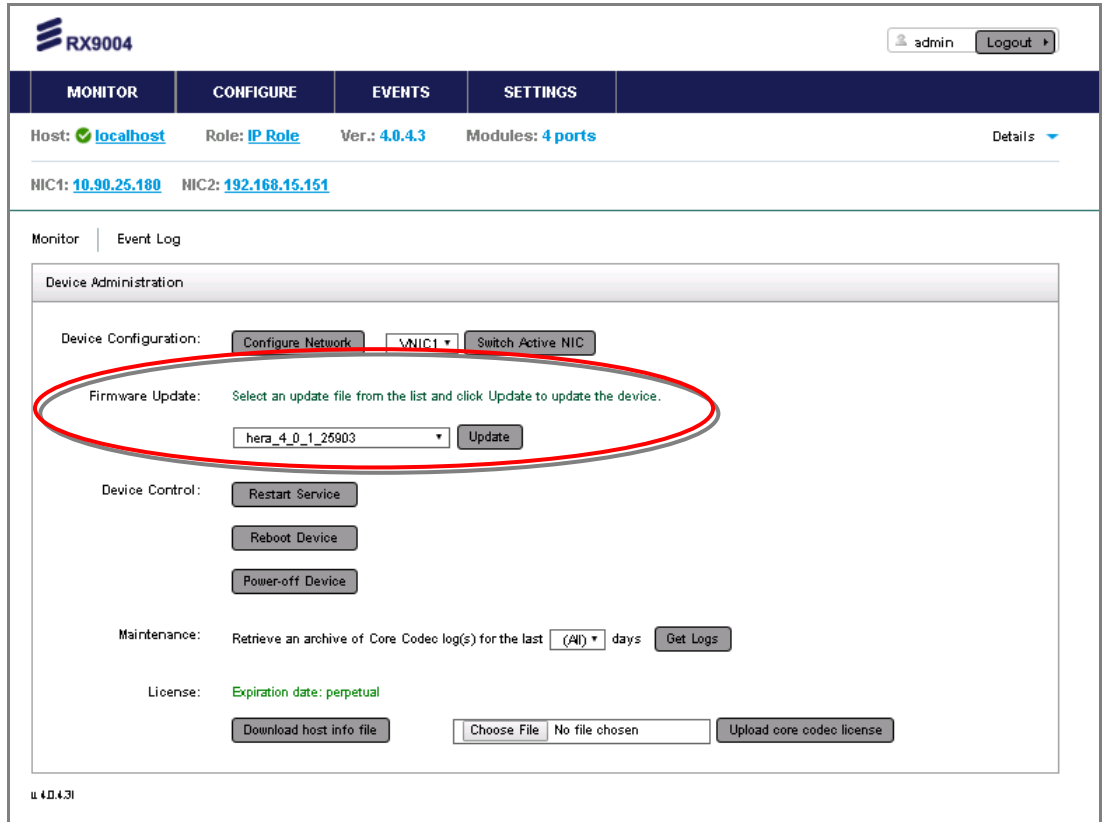

Figure 7.2 Decoder Firmware Update

6. After a few seconds a message will be displayed to indicate the result of the update process. An event log entry is also generated to indicate the completion of the firmware update process.

Note: The firmware update process typically takes less than 10 seconds to complete. No system restart/reboot is required unless stated otherwise in the firmware release notes.

7. Verify that the new Decoder firmware version number is displayed at the top of the **MONITOR** page.

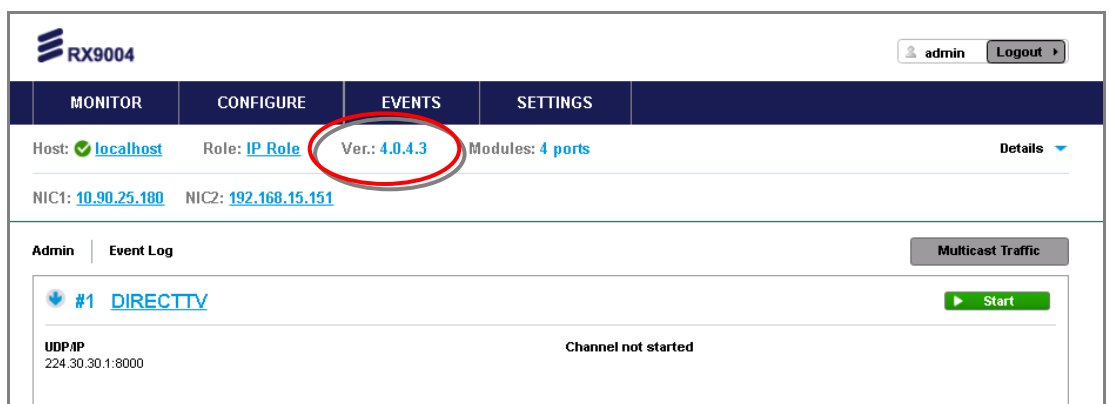

Figure 7.3 Confirming the Decoder Firmware Version Number

7.2.2 Updating the Management System

Management System firmware files are prefixed with 'hms'. Updating this firmware is a two stage process: Upload the file then Update (apply) the file.

Firmware updates are only available only from Ericsson. Always check the validity of the firmware before attempting to upgrade a device.

To update the Management System firmware:

1. Go to the **SETTINGS > Update** page.
2. In the **RX9004 Management System** panel, choose the new firmware file by clicking the **Choose File** button and then navigating to the file location.

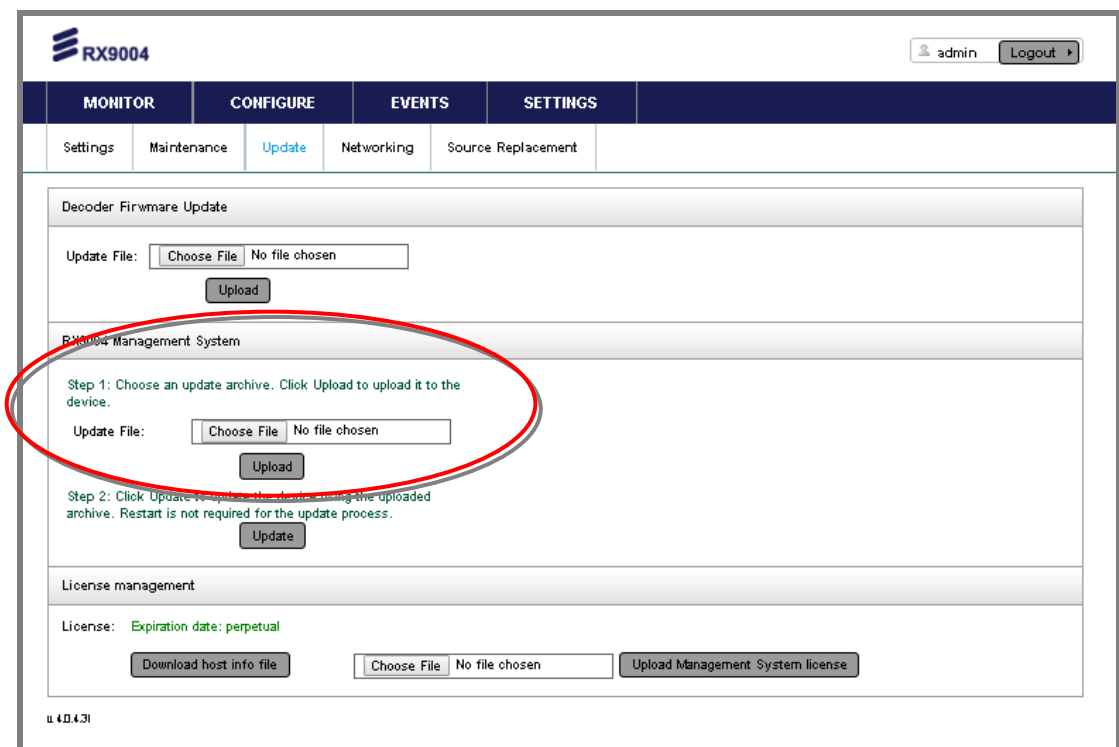

Figure 7.4 Management System Firmware Upload

3. With the new firmware file selected, and its name displayed in the **Update File** field, click the **Upload** button.

Note: Allow time for the operation to complete before navigating away from this page. Due to the size of the binary (~35 MBs) the firmware upload process may take several minutes (especially over slower network connections).

4. When the firmware is uploaded, click the **Update** button.

Note: The firmware update process typically takes less than 10 seconds to complete. No system restart/reboot is required unless stated otherwise in the firmware release notes.

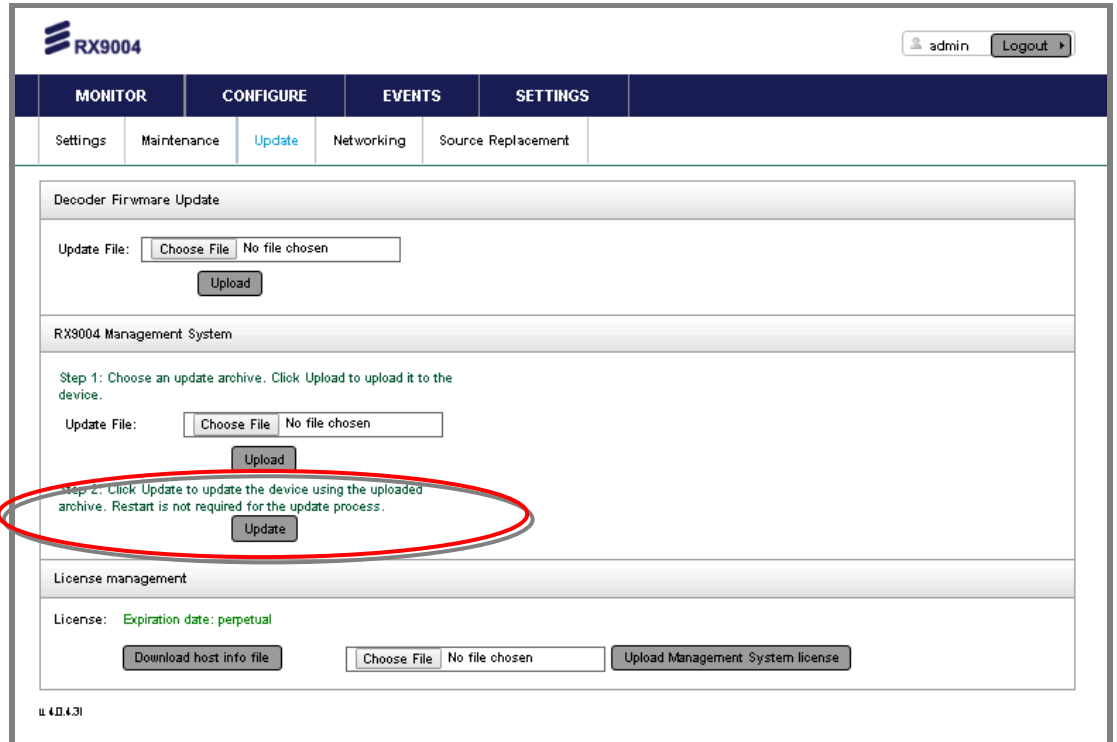

Figure 7.5 Management System Firmware Update

5. Verify that the new Management System firmware version number is displayed at the bottom left-hand corner of the **MONITOR** page.

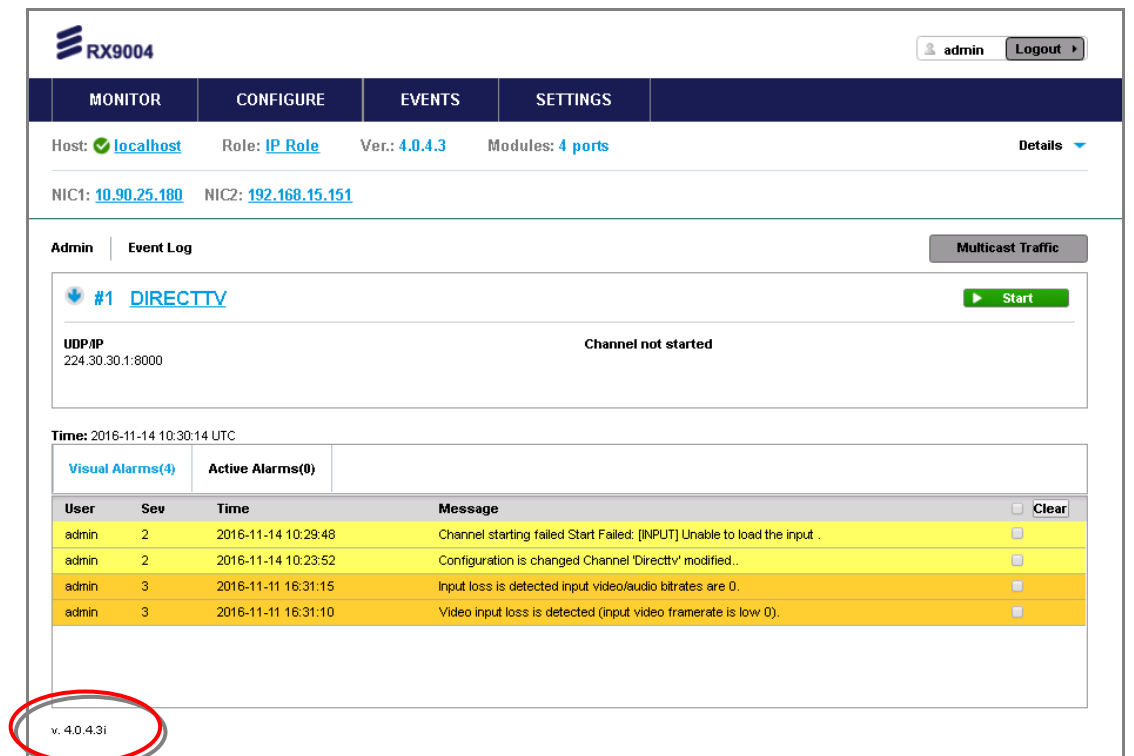

Figure 7.6 Confirming the Management System Firmware Version Number

7.2.3 Updating Core Codec License

Core Codec licenses are only available only from Ericsson. Always check the validity of the licenses before attempting to upgrade a device.

To update the Core Codec License:

1. Go to the **MONITOR > Admin** page.
2. In the **Device Administration** panel, choose the new license file by clicking the **Choose File** button and then navigating to the file location.

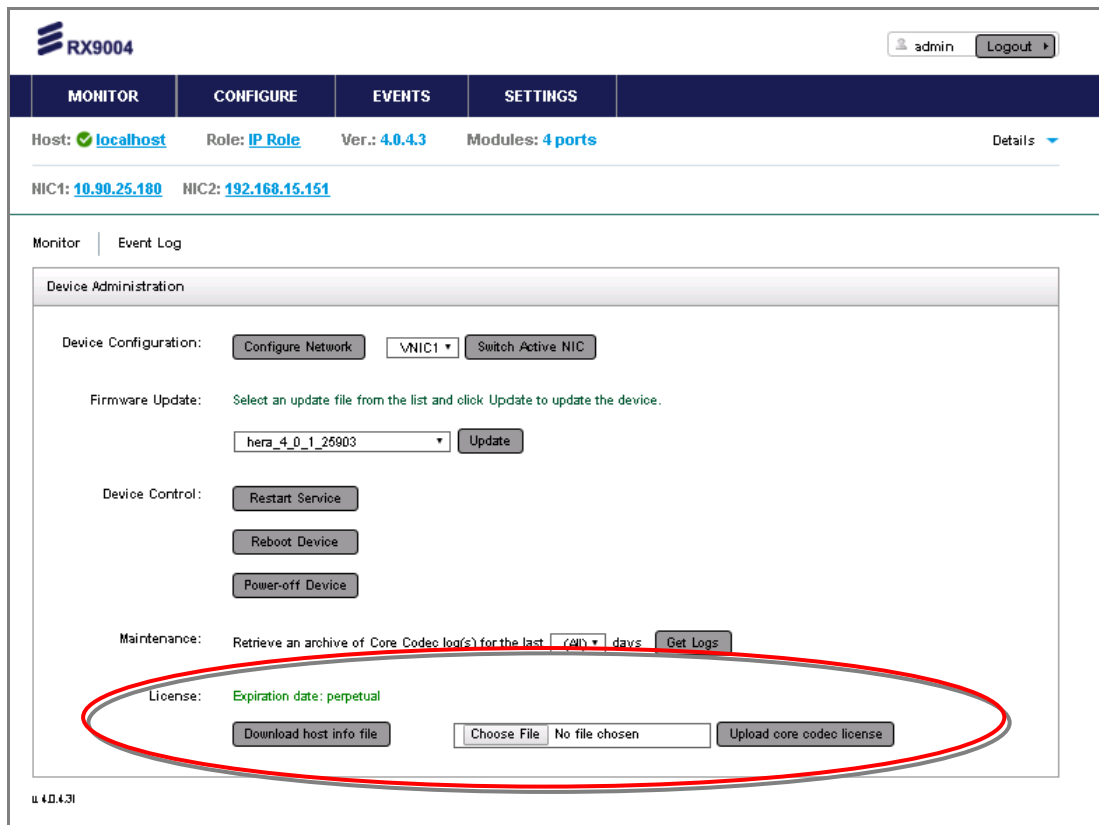

Figure 7.7 Core Codec License Update

3. Click the **Upload core codec license** button to upload the new license file.
4. For the license(s) to take affect perform a system reboot by clicking the **Restart Device** button on this page.

Note: The restart process typically takes less than 1 minute to complete.

7.2.4 Updating Management System License

Management System licenses are only available only from Ericsson. Always check the validity of the licenses before attempting to upgrade a device.

To update the Management System License:

1. Go to the **SETTINGS > Update** page.
2. In the **License Management** panel, choose the new license file by clicking the **Choose File** button and then navigating to the file location.

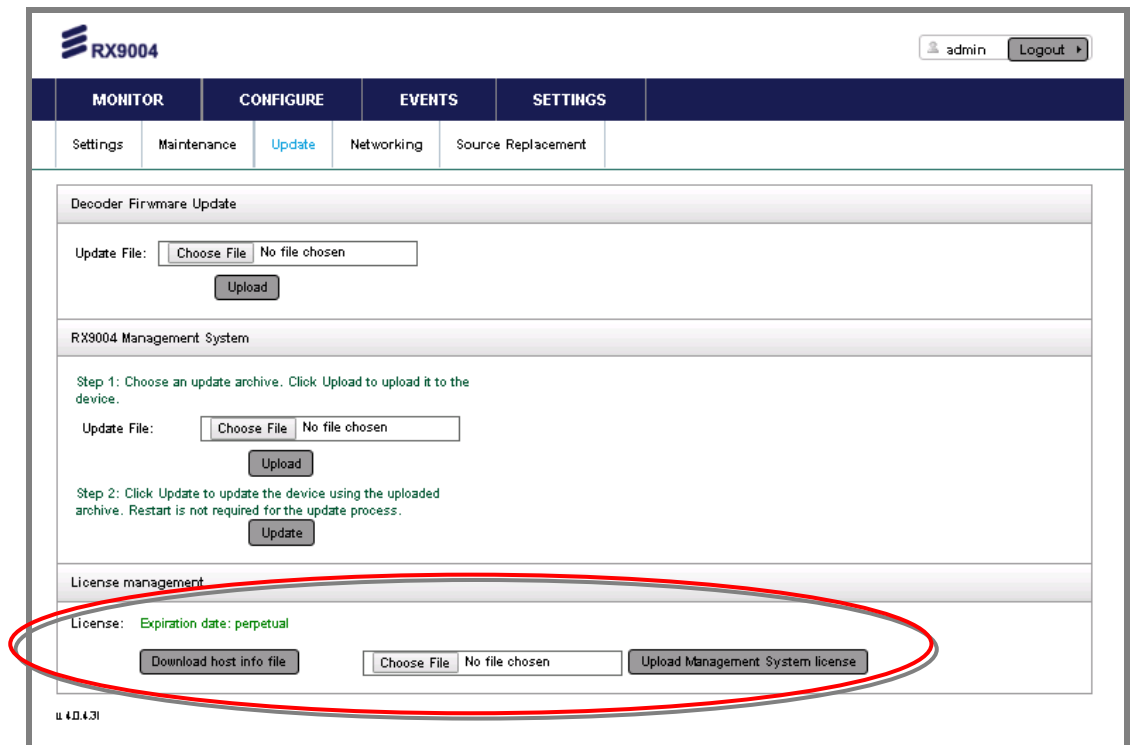

Figure 7.8 Management System License Update

3. Click the **Upload Management System license** button to upload the new license file.
4. For the license(s) to take affect perform a system reboot by clicking the **Restart Device** button on this page.

Note: The restart process typically takes less than 1 minute to complete.

7.3 Removal and Replacement of Modules

This section gives information relating to the handling of option modules as they are inserted or removed from the unit.

7.3.1 Handling Modules



Caution!

Care must be taken to when inserting or withdrawing modules to avoid damage to underside components.

Modules must be kept orthogonal, i.e. at 90 degrees to the unit, to avoid catching underside components on the chassis.

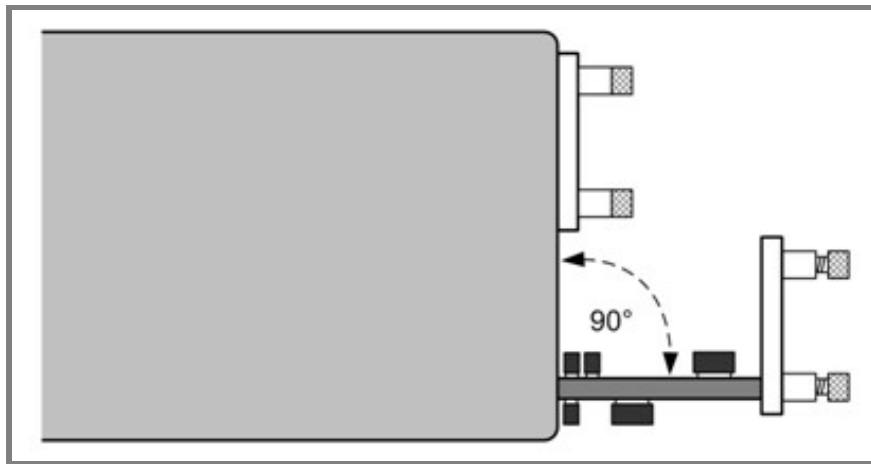

Figure 7.9 Inserting and Withdrawing Modules



Caution!

Do not plug in modules with excessive force as this may result in damage to the module connector or other components. If any significant resistance to inserting a module is felt, withdraw the module slightly and check for obstructions.

7.3.2

Electrostatic Discharge



Warning!

Static electricity can damage electronic components. To avoid damage, keep modules in their static-protective package until you are ready to install them.

To reduce the possibility of electrostatic discharge, observe the following precautions:

- Where possible ensure that antistatic protection is worn (for example an earthed antistatic wrist strap, an ankle or heel strap).
- Handle modules carefully, holding them by edges or rear panels.
- Do not touch solder joints, pins, or exposed printed circuitry.
- Do not leave the modules where others can handle and possibly damage them.
- While the module is still in its anti-static package, touch it to an unpainted metal part of the system unit for at least two seconds. (This drains static electricity from the package and from your body).
- Remove the module from its package and install it directly into your base chassis without setting it down. If it is necessary to set the module down, place it in its static-protective package.
- Take additional care when handling modules during cold weather, because heating reduces indoor humidity and increases static electricity.



BLANK



Preventive Maintenance and Fault-finding

Chapter 8

Contents

8.1	Introduction	8-3
8.2	Preventive Maintenance	8-3
8.2.1	Routine Inspection.....	8-3
8.2.2	Cleaning	8-3
8.2.3	Servicing	8-3
8.2.3.1	Damage Requiring Service.....	8-3
8.2.3.2	Replacement Parts	8-4
8.2.3.3	Checks on Completion of Servicing	8-4
8.3	Maintenance and Support.....	8-4
8.3.1	Introduction	8-4
8.3.2	Warranty.....	8-4
8.3.3	Service Levels Agreements.....	8-4
8.4	Monitoring, Exploring and Managing Alarms	8-5
8.4.1	Monitoring Alarms (and Events).....	8-5
8.4.2	Exploring Alarms (and Events)	8-6
8.4.3	Managing Alarms (and Events)	8-7
8.5	Fault-finding.....	8-8
8.5.1	Fault-finding Philosophy	8-8
8.5.2	Preliminary Checks.....	8-9
8.5.3	Power Supply Problems/Unit Not Working.....	8-10
8.5.3.1	Fuse Replacement	8-10
8.5.3.2	Lithium Battery	8-10
8.5.4	Fan(s) Not Working/Overheating	8-10
8.5.5	Cannot Access Web GUI.....	8-11
8.5.6	Cannot Ping the Unit	8-12
8.5.7	Operational Problems.....	8-12
8.6	SNMP Traps.....	8-14
8.6.1	What Is An SNMP Trap?	8-14
8.6.2	Supported Protocols	8-14
8.6.3	Operation	8-14
8.6.4	SNMP Interface Parameters.....	8-15
8.7	Calling a Service Engineer	8-15
8.7.1	Viewing Management System and Decoder Firmware Version Numbers.....	8-16
8.7.2	Capturing Management System Log Data	8-17
8.7.3	Capturing Device Log Data.....	8-18
8.7.4	Exporting a Channel Configuration File	8-20



List of Figures

Figure 8.1	MONITOR Page.....	8-5
Figure 8.2	CONFIGURE > Events Page	8-6
Figure 8.3	CONFIGURE > Events Page	8-7
Figure 8.4	Management System and Decoder Firmware Version Numbers	8-16
Figure 8.5	Decoder Firmware Version Number	8-17
Figure 8.6	Management System Logs	8-18
Figure 8.7	MONITOR Admin Link	8-19
Figure 8.8	Device Logs	8-19
Figure 8.9	Channel Selection.....	8-20
Figure 8.10	Export Channel Configuration File.....	8-21

List of Tables

Table 8.1	Status LED Unlit Fault-finding	8-10
Table 8.2	Fans Not Working/Overheating	8-11
Table 8.3	Cannot Access Web GUI	8-11
Table 8.4	Unit Cannot be Pinged	8-12
Table 8.5	Operational Problems	8-13
Table 8.6	SNMP Interface Parameters	8-15

8.1 Introduction

This chapter details the schedules and instructions, where applicable, for routine inspection, cleaning and maintenance of the equipment which should be performed by an operator. It also details basic fault-finding procedures.

8.2 Preventive Maintenance

8.2.1 Routine Inspection

Check cooling fan operation regularly. The fans are temperature controlled so may not be on if the ambient temperature is low. Refer to *Annex B, Technical Specification* for more information.

Note: Failure to ensure a free flow of air around the unit may cause overheating and an alarm to be raised.

8.2.2 Cleaning



Caution!

Do not use liquid cleaners or aerosol cleaners.

Unplug the unit from the wall outlet before cleaning the exterior with a damp cloth. Do not use liquid cleaners or aerosol cleaners.

Note: Only the exterior of the case should be cleaned.

8.2.3 Servicing

8.2.3.1 Damage Requiring Service



Warning!

Do not remove the top cover of this equipment. Hazardous voltages are present within this equipment and may be exposed if the top cover is removed. Only Ericsson trained and approved service engineers are permitted to service this equipment.

Unplug the equipment from the wall outlet and refer servicing to qualified service personnel under the following conditions:

- When the power supply cord or plug is damaged.



- If liquid has been spilled, or objects have fallen into the product.
- If the product has been exposed to rain or water.
- If the product does not operate normally by following the operating instructions.
- If the product has been dropped or the case has been damaged.
- When the product exhibits a distinct change in performance.

8.2.3.2 Replacement Parts

When replacement parts are required, be sure the service technician has used parts specified by the manufacturer or which have the same characteristics as the original part. Unauthorized substitutions may result in fire, electric shock or other hazards.

8.2.3.3 Checks on Completion of Servicing

Upon completion of any service or repairs to this product, ask the service technician to perform electrical safety checks to determine that the product is in a safe operating condition. Also, performance and EMC checks may be required.

8.3 Maintenance and Support

8.3.1 Introduction

Ericsson is a leader in the design, integration and implementation of digital broadcasting products and systems. It has a large team dedicated to keeping our customers on-air 24 hours a day, 365 days a year.

With regional offices worldwide, and ultra-modern specialist service facilities in the US, UK, and Asia, Ericsson covers the world. There is a customer service centre open round the clock, every day of the year.

Years of design and support experience enable it to offer a range of service options that will meet your needs at a price that makes sense.

8.3.2 Warranty

All Ericsson products and systems are designed and built to the highest standards and are covered under a comprehensive 12 month warranty.

8.3.3 Service Levels Agreements

Customers may choose one of several Support packages, either as an enhancement during the standard 12-month warranty or as an extension after the warranty has expired.

For standalone equipment, customers may choose either Ericsson’s **Extended Hardware Warranty** or **Secure Basic Support**. Extended Hardware Warranty provides hardware repair of covered equipment after the expiration of the standard warranty. Secure Basic Support provides hardware repair, remote diagnostics and support, and 24x7x365 remote support for emergencies.

For systems, along with Secure Basic Support, customers have the option of either **Secure Advanced Support** or **Secure Superior Support**. These support packages provide higher committed response and resolution times, onsite support where necessary, service performance review and a host of other proactive services to help you get the maximum return on your investment in Ericsson solutions.

Call Ericsson Sales for more details.

8.4 Monitoring, Exploring and Managing Alarms

8.4.1 Monitoring Alarms (and Events)

Alarms and other operational events can be monitored using the MONITOR page.

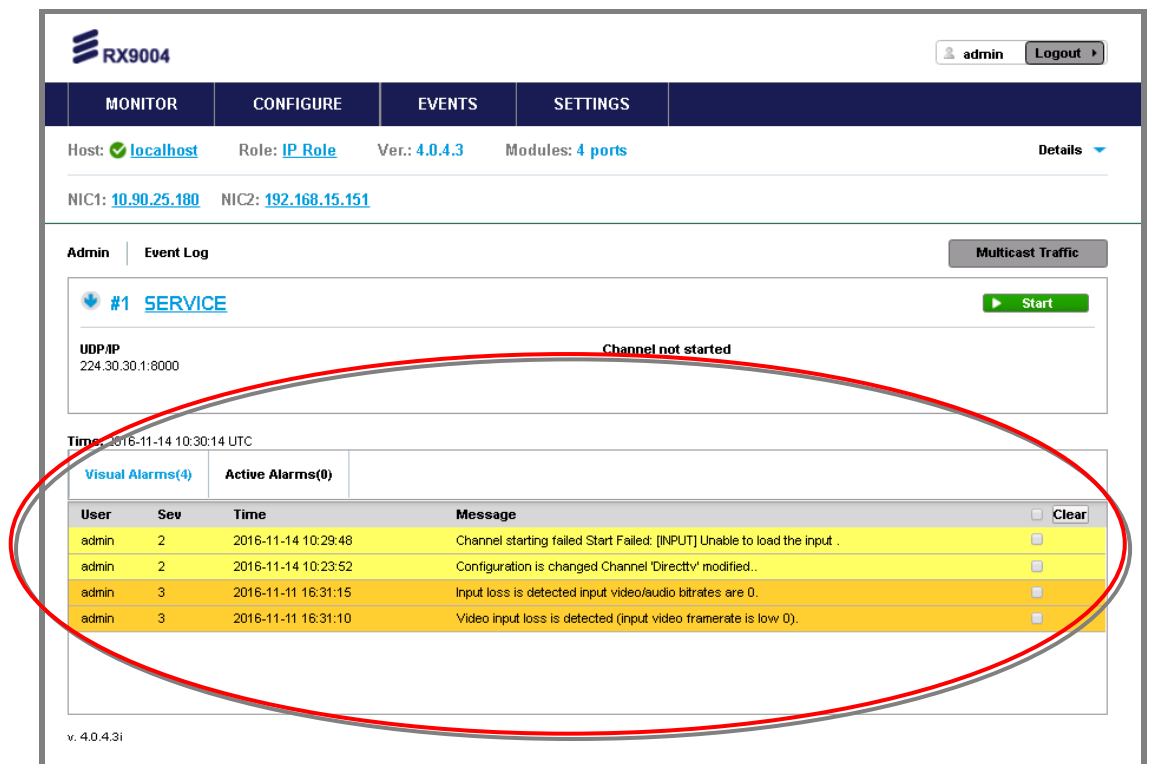

The screenshot shows the MONITOR page for RX9004. The top navigation bar includes MONITOR, CONFIGURE, EVENTS, and SETTINGS. The system status is displayed as follows:

- Host: ✔ localhost
- Role: [IP Role](#)
- Ver.: 4.0.4.3
- Modules: 4 ports
- NIC1: [10.90.25.180](#)
- NIC2: [192.168.15.151](#)

The main content area shows an 'Admin' section with an 'Event Log' tab. A 'Multicast Traffic' button is visible. Below this, there is a section for '#1 SERVICE' with a 'Start' button. The status 'Channel not started' is displayed. A table of Visual Alarms is shown below, with a red oval highlighting it:

User	Sev	Time	Message	Clear
admin	2	2016-11-14 10:29:48	Channel starting failed Start Failed: [INPUT] Unable to load the input .	<input type="checkbox"/>
admin	2	2016-11-14 10:23:52	Configuration is changed Channel 'Directtv' modified..	<input type="checkbox"/>
admin	3	2016-11-11 16:31:15	Input loss is detected input video/audio bitrates are 0.	<input type="checkbox"/>
admin	3	2016-11-11 16:31:10	Video input loss is detected (input video framerate is low 0).	<input type="checkbox"/>

Figure 8.1 MONITOR Page

Viewing Events

The most recent alarms, and other operational events, can be monitored directly from the MONITOR page and are displayed in the lower half of this page. **User Severity, Time** and **Message** are displayed.

Acknowledging Events

Alarms and other operational events can be acknowledged and removed (hidden) from this list by placing a check mark in the check box alongside the relevant event. Alternatively, you can clear all alarms by placing a check mark in the box at the top of the table column.

Visual alarms relate to a video failure.

8.4.2 Exploring Alarms (and Events)

Alarms and other operational events can be explored using the **EVENTS** page.

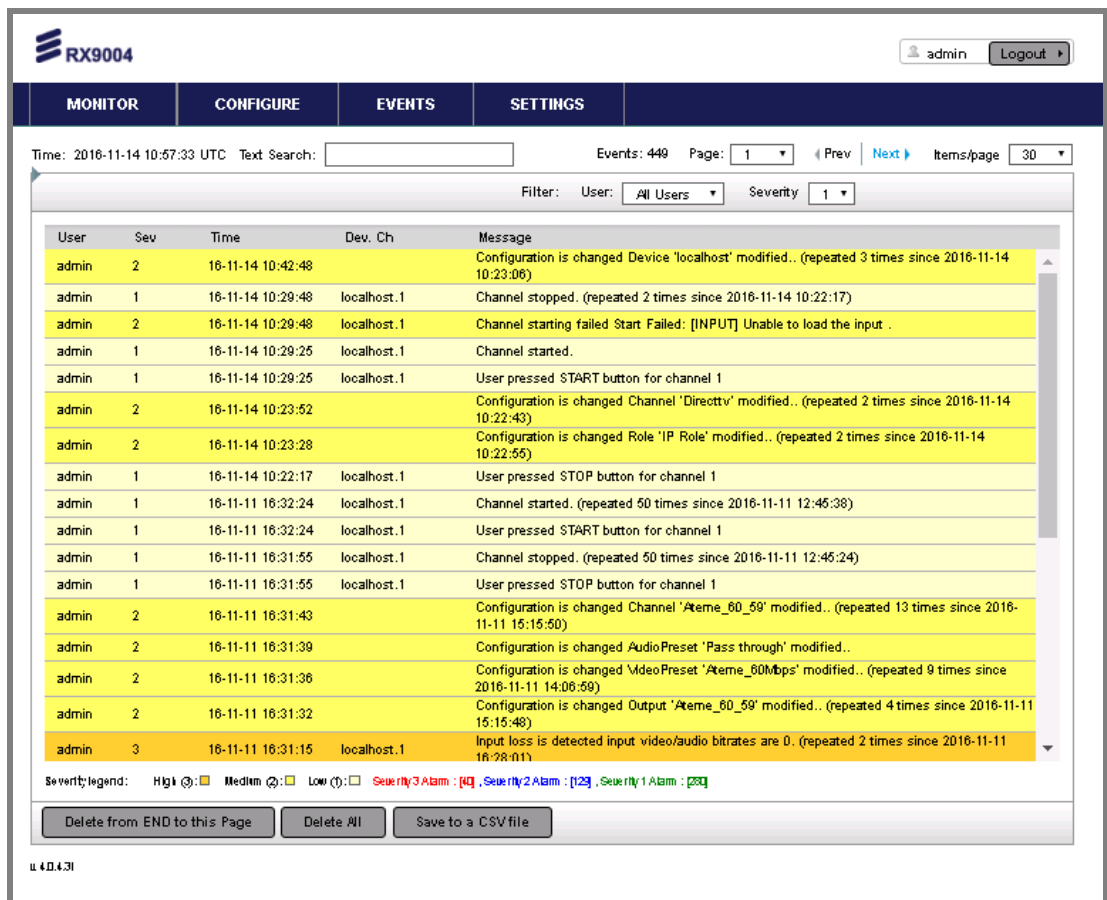

The screenshot shows the 'EVENTS' page in the RX9004 interface. At the top, there are navigation tabs for MONITOR, CONFIGURE, EVENTS, and SETTINGS. The 'EVENTS' tab is active. Below the tabs, there is a header area with 'Time: 2016-11-14 10:57:33 UTC', a 'Text Search:' field, and 'Events: 449'. There are also 'Page: 1', 'Prev', 'Next', and 'Items/page: 30' controls. A filter section shows 'User: All Users' and 'Severity: 1'. The main content is a table with the following columns: User, Sev, Time, Dev. Ch, and Message. The table contains 18 rows of event data. At the bottom of the table, there is a 'Severity legend' and three buttons: 'Delete from END to this Page', 'Delete All', and 'Save to a CSV file'.

User	Sev	Time	Dev. Ch	Message
admin	2	16-11-14 10:42:48		Configuration is changed Device 'localhost' modified.. (repeated 3 times since 2016-11-14 10:23:06)
admin	1	16-11-14 10:29:48	localhost.1	Channel stopped. (repeated 2 times since 2016-11-14 10:22:17)
admin	2	16-11-14 10:29:48	localhost.1	Channel starting failed Start Failed: [INPUT] Unable to load the input .
admin	1	16-11-14 10:29:25	localhost.1	Channel started.
admin	1	16-11-14 10:29:25	localhost.1	User pressed START button for channel 1
admin	2	16-11-14 10:23:52		Configuration is changed Channel 'Directtv' modified.. (repeated 2 times since 2016-11-14 10:22:43)
admin	2	16-11-14 10:23:28		Configuration is changed Role 'IP Role' modified.. (repeated 2 times since 2016-11-14 10:22:55)
admin	1	16-11-14 10:22:17	localhost.1	User pressed STOP button for channel 1
admin	1	16-11-11 16:32:24	localhost.1	Channel started. (repeated 50 times since 2016-11-11 12:45:38)
admin	1	16-11-11 16:32:24	localhost.1	User pressed START button for channel 1
admin	1	16-11-11 16:31:55	localhost.1	Channel stopped. (repeated 50 times since 2016-11-11 12:45:24)
admin	1	16-11-11 16:31:55	localhost.1	User pressed STOP button for channel 1
admin	2	16-11-11 16:31:43		Configuration is changed Channel 'Ateme_60_59' modified.. (repeated 13 times since 2016-11-11 15:15:50)
admin	2	16-11-11 16:31:39		Configuration is changed AudioPreset 'Pass through' modified..
admin	2	16-11-11 16:31:36		Configuration is changed VideoPreset 'Ateme_60Mbps' modified.. (repeated 9 times since 2016-11-11 14:06:59)
admin	2	16-11-11 16:31:32		Configuration is changed Output 'Ateme_60_59' modified.. (repeated 4 times since 2016-11-11 15:15:48)
admin	3	16-11-11 16:31:15	localhost.1	Input loss is detected input video/audio bitrates are 0. (repeated 2 times since 2016-11-11 16:28:01)

Severity legend: High (3) Medium (2) Low (1) Security/3 Alarm : (4) , Security/2 Alarm : (12) , Security/1 Alarm : (23)

Buttons: Delete from END to this Page, Delete All, Save to a CSV file

u 4.0.4.31

Figure 8.2 CONFIGURE > Events Page

Displaying Events

All operational and alarm events are displayed on the **SETTINGS > Events** page. Events are displayed with the most recent at the top of the page, with the list extending to multiple pages when required. The number of events and number of pages of events are displayed at the top of the page. The pages of events can be viewed by clicking the **< Prev** and **Next >** buttons and the number of events displayed on each page can be modified by selecting the required number in the **Items/page** drop-down list on the top right-hand side.

A text search can be performed if looking for key words or, alternatively, the event can be filtered to display only those events by **User** or **Severity**.

Deleting and Saving Events

Older pages of events can be deleted by using either the **Delete from END to this Page** or **Delete All** button. Alternatively, they can be saved as a comma separated variable file by clicking the **Save to a CSV file** button.

8.4.3 Managing Alarms (and Events)

Alarms and other operational events can be managed using the **CONFIGURE > Events** page.

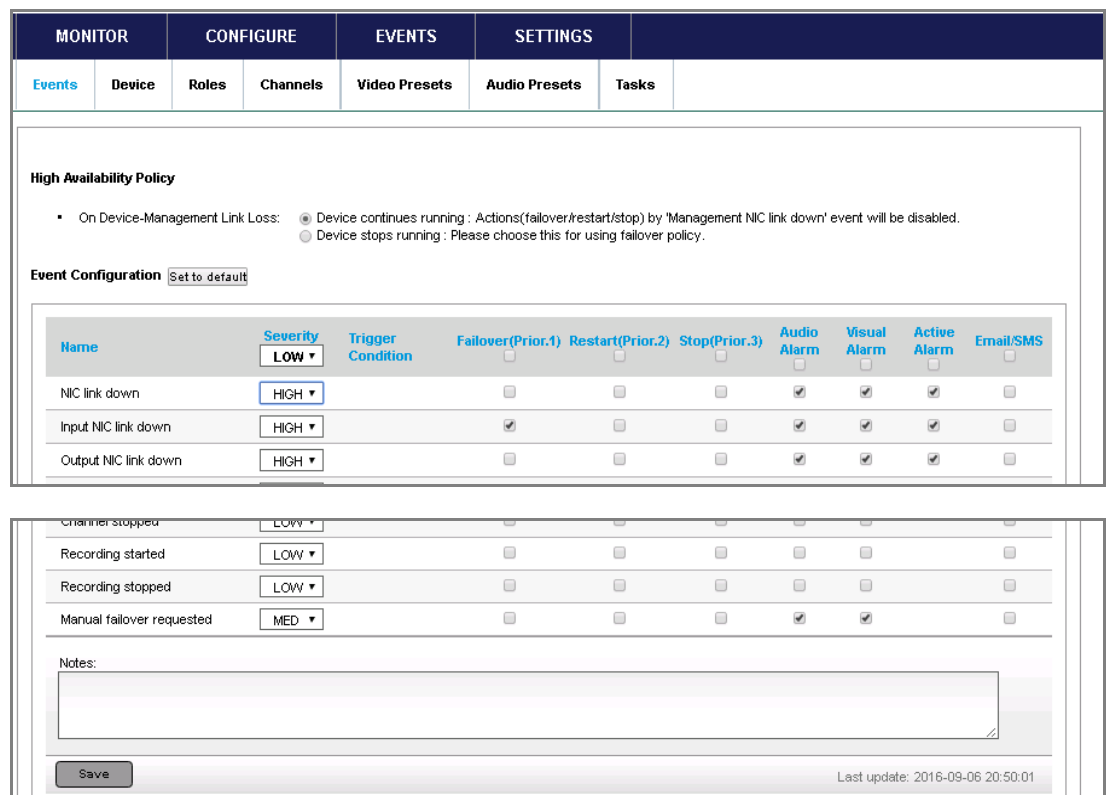

The screenshot shows the 'CONFIGURE > Events' page. At the top, there are navigation tabs: MONITOR, CONFIGURE, EVENTS, and SETTINGS. Under 'CONFIGURE', there are sub-tabs: Events, Device, Roles, Channels, Video Presets, Audio Presets, and Tasks. The 'Events' sub-tab is active.

Below the tabs, there is a section for 'High Availability Policy' with a radio button selection for 'On Device-Management Link Loss':

- Device continues running : Actions(failover/restart/stop) by 'Management NIC link down' event will be disabled.
- Device stops running : Please choose this for using failover policy.

Below this is the 'Event Configuration' section with a 'Set to default' link. It contains a table of events with columns for Name, Severity, Trigger Condition, Failover(Prior.1), Restart(Prior.2), Stop(Prior.3), Audio Alarm, Visual Alarm, Active Alarm, and Email/SMS.

Name	Severity	Trigger Condition	Failover(Prior.1)	Restart(Prior.2)	Stop(Prior.3)	Audio Alarm	Visual Alarm	Active Alarm	Email/SMS
NIC link down	LOW		<input type="checkbox"/>	<input type="checkbox"/>	<input type="checkbox"/>	<input checked="" type="checkbox"/>	<input checked="" type="checkbox"/>	<input checked="" type="checkbox"/>	<input type="checkbox"/>
Input NIC link down	HIGH		<input checked="" type="checkbox"/>	<input type="checkbox"/>	<input type="checkbox"/>	<input checked="" type="checkbox"/>	<input checked="" type="checkbox"/>	<input checked="" type="checkbox"/>	<input type="checkbox"/>
Output NIC link down	HIGH		<input type="checkbox"/>	<input type="checkbox"/>	<input type="checkbox"/>	<input checked="" type="checkbox"/>	<input checked="" type="checkbox"/>	<input checked="" type="checkbox"/>	<input type="checkbox"/>
Channeler stopped	LOW		<input type="checkbox"/>	<input type="checkbox"/>	<input type="checkbox"/>	<input type="checkbox"/>	<input type="checkbox"/>	<input type="checkbox"/>	<input type="checkbox"/>
Recording started	LOW		<input type="checkbox"/>	<input type="checkbox"/>	<input type="checkbox"/>	<input type="checkbox"/>	<input type="checkbox"/>	<input type="checkbox"/>	<input type="checkbox"/>
Recording stopped	LOW		<input type="checkbox"/>	<input type="checkbox"/>	<input type="checkbox"/>	<input type="checkbox"/>	<input type="checkbox"/>	<input type="checkbox"/>	<input type="checkbox"/>
Manual failover requested	MED		<input type="checkbox"/>	<input type="checkbox"/>	<input type="checkbox"/>	<input checked="" type="checkbox"/>	<input checked="" type="checkbox"/>	<input type="checkbox"/>	<input type="checkbox"/>

Below the table is a 'Notes' section with a text area and a 'Save' button. At the bottom right, it says 'Last update: 2016-09-06 20:50:01'.

Figure 8.3 CONFIGURE > Events Page

Modifying Event Severity

The severity of any of the events listed on this page can be modified by changing the setting in the **Severity** column to LOW, MED or HIGH.

Note: If the alarm is masked it will not be displayed on any of the reporting interfaces, and will not produce an SNMP trap message.



Modifying Device Operation When an Event Occurs

By placing a check mark in the appropriate check box, the operation of the Device can be controlled automatically by the occurrence of an event:

- **Failover(Prior.1)** – when priority 1 option is selected, users can use this alarm status to trigger a redundancy switch.
- **Restart(Prior.2)** – when priority 2 option is selected, this causes the Device to perform a restart of decoding.
- **Stop(Prior.3)** – when priority 3 option is selected, this causes the Device operation to stop outputting.

Configuring Alarm Indications

By placing a check mark in the appropriate check box, an alarm indication can be triggered by the occurrence of an event:

- **Audio Alarm** – when selected, this indicates audio issues.
- **Visual Alarm** – when selected, this indicates video issues.
- **Active Alarm** – when selected, this shows which additional alarms are active.
- **Email/SMS** – when selected, this causes an email or SMS to be sent to a predetermined address.

8.5 Fault-finding

8.5.1 Fault-finding Philosophy

It is the objective of this section to provide sufficient information to enable you to rectify apparent faults or else to identify the suspect module, where possible. Some basic procedures are provided to follow in the event of a suspected failure. It is assumed that fault-finding has already been performed at a system level and that other equipment units have been eliminated as the possible cause of the failure.



Warning!

Do not remove the top cover of this equipment. Hazardous voltages are present within this equipment and may be exposed if the top cover is removed. Only Ericsson trained and approved service engineers are permitted to service this equipment.



Caution!

Do not remove the top cover of this equipment as this may invalidate any warranties. Unauthorised maintenance or the use of non-approved replacements may affect the equipment specification and invalidate any warranties.

This Reference Guide does not include any maintenance information or procedures that would require the removal of the top cover.

If the following information fails to clear the abnormal condition, call a Service Engineer or contact Customer Services using the information given in the preliminary pages of this Reference Guide.

8.5.2 Preliminary Checks

Always investigate the failure symptoms fully, prior to taking remedial action. Fault diagnosis for the equipment operator is limited to the following tasks, since the operator should **NOT** remove the covers of the equipment:

1. Check the front panel and web GUI alarm indications to specify the nature of the fault.
2. Confirm that the equipment hardware configuration is suitable for the purpose and has been correctly installed and connected (see *Chapter 2, Installing the Equipment*).
3. Confirm that inappropriate operator action is not causing the problem, and that the equipment software set-up is capable of performing the task being asked of it. If the validity of the configuration, set-up or operation is in doubt, check it (see *Chapter 5, Web GUI Control*).
4. Check that the fans are unobstructed and working correctly.

When the failure condition has been fully investigated, and the symptoms are known, proceed with fault-finding according to the observed symptoms. If the fault persists, and cannot be rectified using the instructions given in this Reference Guide, contact Customer Services. Switch off the equipment if it becomes unusable, or to protect it from further damage.

8.5.3 Power Supply Problems/Unit Not Working

If the unit Status LED is unlit, fault-find the problem as detailed in *Table 8.1*.

Table 8.1 Status LED Unlit Fault-finding

Step	Action	If Result of Action is Yes...	If Result of Action is No...
1	Confirm Display Operation. Is the display inactive but the unit still working?	If the unit is clearly working normally then the Display itself is probably at fault. Call a Service Engineer.	Proceed to next step.
2	Check Power Source. Connect a known-working piece of equipment to the power source outlet. Does it work?	The problem lies within the unit or power cable. Proceed to next step.	The problem lies with the power source. Check building circuit breakers, fuse boxes, etc. If problem persists, contact the electricity supplier.
3	Check Power Cable and Fuse. Unplug the power connector from the unit and try it in another piece of equipment. Does it work?	The problem lies within the unit. Proceed to next step.	The problem lies with either the cable itself, or with the fuse in the plug. Replace the fuse or try to substitute another cable.
4	Check PSU Module(s) and Fuse(s). Ensure the power connector is unplugged. Remove the fuse from the rear panel connector and inspect it. Has the fuse blown?	Replace the fuse with one of the correct type and rating (see <i>Annex B Technical Specification</i>). If the PSU still does not work, unplug the power cable and call a Service Engineer.	Possible problem with the PSU module. Call a Service Engineer.

8.5.3.1 Fuse Replacement

Please refer to the *Installation, Safety and Compliance Information for Ericsson Compression Products Reference Guide* supplied with your product for full details of how to replace the fuse in your product.

8.5.3.2 Lithium Battery

The lithium battery fitted within this product is not user replaceable and as such should only be replaced by qualified service personnel.

8.5.4 Fan(s) Not Working/Overheating

The fan speed can be reduced (set to lowest noise) at low temperatures to allow the unit to quickly attain operational temperature. In the event of overheating problems, refer to *Table 8.2*.

Note: Failure to ensure a free air-flow around the unit may cause overheating. This condition is detected by a temperature sensor; it may be used to trigger an automatic alarm.



Warning!

The fans run at high speeds. DO NOT insert objects into the front of the unit when attempting to confirm fan rotation as this may result in injury or damage to the fans and the unit.

Table 8.2 Fans Not Working/Overheating

Step	Action	If Result of Action is Yes...	If Result of Action is No...
1	Check Fan Rotation. Inspect the fans located at the sides of the enclosure. Are the fans rotating? Check Base Board temperature and fan.	Check that the unit has been installed with sufficient space allowed for air-flow (see <i>Chapter 2, Installing the Equipment</i>). If the ambient air is too hot, additional cooling may be required.	Possible break in the DC supply from the PSU module to the suspect fan(s). Call a Service Engineer.

8.5.5

Cannot Access Web GUI

In the event that you cannot access the web GUI, refer to *Table 8.3*.

Table 8.3 Cannot Access Web GUI

Step	Action	If Result of Action is Yes...	If Result of Action is No...
1	Check IP Connectivity. Ping the unit from another device on the same IP subnet using the device command prompt. Does the unit return the ping?	Ensure you are using an appropriate browser. See <i>Chapter 5, Web GUI Control</i> for details. Proceed to next step.	Check you have the correct IP address. See <i>Cannot Ping the Unit</i> , below.
2	Check other unit web GUIs or websites. Does the browser access other IP addresses?	There is a problem with the unit. Proceed to next step.	There is a problem with the computer you are using to access the network, or with the network.
3	Restart the Unit. Can you access the web GUI now?	Check your configuration. You may need to reload a saved configuration to restore your system.	Possible problem with the unit. Call a Service Engineer.

8.5.6 Cannot Ping the Unit

Pinging a computer is a method of checking if a computer is on the network. Pings send a network request to a computer asking it to respond (ICMP ECHO_REQUEST).

To ping a computer from a Windows/PC machine, use the MSDOS prompt and type the command: **ping <IP address>**

A successful 'ping' consists of receiving back a copy of a short transmitted test message. The reply will display 'ping statistics' (number of packets sent and received and the time taken, in ms, to receive back those packets).

In the event that you cannot ping your unit, refer to *Table 8.4*.

Table 8.4 Unit Cannot be Pinged

Step	Action	If Result of Action is Yes...	If Result of Action is No...
1	Check Connection at back of PC. Is the network connection connected and active?	Possible network or unit problem. Proceed to next step.	Change port/replace cable, if necessary, and check network settings.
2	Check Connection at back of unit. Is the network connection connected and active?	Possible network problem. Proceed to next step.	Change port/replace cable, if necessary, and check network settings.
3	Check network switch operation. Is the network switch connected and active?	Possible network problem. Proceed to next step.	Change port/replace cable/replace network switch, if necessary, and check network settings.
4	Check network operation. Ping other devices on the same IP subnet using the device command prompt. Can you ping other devices?	Network is operational. Possible unit problem. Call a Service Engineer.	Possible problem with IP switch, router or network. Contact your network administrator.

8.5.7 Operational Problems

Refer to the table below to self-diagnose/troubleshoot issues related to operational problems.

Table 8.5 Operational Problems

Problem	Trouble-Shooting Steps
Appliance does not turn on.	Ensure proper power is provided to the unit. (On both PSUs, if applicable).
	1. Ensure that the PSUs are firmly inserted on the rear of the unit. Try to remove and re-insert them.
	2. Press the  button on the front panel for 2 seconds.
	3. Completely unplug the power cable from the unit for 30 seconds and retry.
Appliance is not accessible over the network.	1. Make sure all connected Network Interface plugs are showing a Green light. If not ensure all Ethernet cables and plugs are properly connected.
	2. Ensure the LCD panel displays IP addresses and use the Restart Network option if no IP addresses are shown.
	3. Make sure the network configuration (IP address, subnet, gateway) of the appliance is correct.
	4. Make sure you are in the same subnet as the IP address of the appliance you are trying to access.
	5. If using DHCP, make sure the traffic in the network is not causing DHCP broadcast packets to be dropped and try Restart Network option from the LCD panel a few times.
	6. Make sure no firewalls or other mechanisms are blocking the network traffic to/from the appliance.
	7. Completely unplug the power cable from the unit for 30 seconds and retry.
Channel fails to start.	1. Refer to the error message for more details.
	2. Make sure that the source is connected to the right port and the feed is available.
	3. Make sure that the source is supported.
	4. Try restating the Channel.
No output.	1. Ensure the BNC ports used are correctly connected.
	2. Make sure Audio/Video Presets and Output parameters are configured correctly.
	3. Make sure that the source is supported.



Problem	Trouble-Shooting Steps
Poor audio and/or video quality.	1. Ensure the correct video standard (NTSC/PAL) is configured for the Video Preset.
	2. Ensure the source has good quality and does not present frequent packet loss.
	3. Make sure post-processing tools are configured correctly.
	4. Ensure audio/video presets are configured correctly and within the specifications of each output type.
	5. Try restarting the Channel.

8.6 SNMP Traps

8.6.1 What Is An SNMP Trap?

Simple Network Management Protocol (SNMP) is an application layer protocol that facilitates the exchange of management information between network devices. It is part of the Transmission Control Protocol/Internet Protocol (TCP/IP) protocol suite and is defined in a set of standards (RFC 1065 - RFC 1067, RFC 1155 - RFC 1157, RFC 1213, RFC 1441 - RFC 1452, RFC 1901 - RFC 1910, RFC 2576, RFC 3411 - RFC 3418) published by the Internet Engineering Task Force (IETF).

8.6.2 Supported Protocols

SNMP versions 1, 2c and 3 are supported, primarily for alarm trap handling. The General Ericsson MIB is also supported.

Note: The unit does not support control via SNMP, all remote control is via HTTP.

8.6.3 Operation

The unit's SNMP functionality can be enabled or disabled, with up to five IP addresses assigned for any SNMP Trap message to be sent. The default is 000.000.000.000, which causes the SNMP traps to be sent to the last SNMP master. The SNMP community name can also be set.

The user can control which SNMP traps are generated. The options are;

- Start Messages only.
- Fail and Start Messages only.
- All Traps.

8.6.4 SNMP Interface Parameters

Table 8.6 SNMP Interface Parameters

Parameter	Description
SNMP Read Community	The SNMP community name for read access. default = public
SNMP Location	Textual description of the location of the unit
SNMP Contact	Name of the person responsible for this unit
SNMP Trap Community	The SNMP community name for read access. default = private
SNMP Trap Destination	The destination IP address for SNMP trap messages. Up to five destinations can be defined, but by default none are assigned
SNMP Trap Alarm Level	Defines what events trigger the generation of an SNMP trap message. The options are: Start Messages Only, i.e. only system start up events. Fail and Start Messages only, i.e. start-up events and critical alarms and All traps, i.e. start-up events and all alarms and warnings.

8.7 Calling a Service Engineer

If you cannot resolve a problem with your equipment using the information provided in this chapter, or if you experience technical or operational difficulties, please do not hesitate to contact us to request assistance.

There is a lot of information you can give us that will enable us to diagnose your problem swiftly. When contacting us please provide the following:

- Serial number.
- Software/firmware version number.
- Management System logs.
- Unit logs.
- Configuration, both hardware and software.
- Channel configuration file(s).
- System architecture and environment.
- Description of the symptoms and what diagnosis and tests have already been attempted.
- Any external events that may be related as triggers of the symptoms. If so, at what local time?
- System logs from any controlling application software, if relevant.

- Where applicable, please also capture samples of source and/or output media.

In addition to the above, please do not forget to provide us with your contact details to enable us to get in touch with you swiftly:

- Name(s).
- Telephone and fax numbers.
- Email address.
- Business address.

8.7.1 Viewing Management System and Decoder Firmware Version Numbers

To view the firmware version numbers:

1. Go to the **MONITOR** page on the Web GUI.
2. The Management System firmware version is indicated at the **bottom left-hand corner** of the Web GUI and is available in all pages/views.
3. The Decoder firmware version is indicated at the Device Monitor page as part of the information section at the **top of the page**.

The screenshot shows the RX9004 Web GUI interface. At the top, there is a navigation bar with tabs for MONITOR, CONFIGURE, EVENTS, and SETTINGS. The MONITOR tab is active. Below the navigation bar, the page displays system information including the host name 'idc.dhruva', IP address '192.168.15.151', and the Decoder Firmware Version 'Ver.: 4.0.4.3', which is circled in red. Below this, there is a section for 'Admin | Event Log' with a 'Multicast Traffic' button and a 'Start' button. The event log shows several entries with columns for User, Sev, Time, and Message. At the bottom left of the page, the Management System Firmware Version 'v. 4.0.4.3i' is displayed and circled in red. Labels on the left side of the image point to these two version numbers.

Figure 8.4 Management System and Decoder Firmware Version Numbers

4. The Decoder firmware version number is also displayed on the **CONFIGURE > Devices** page.

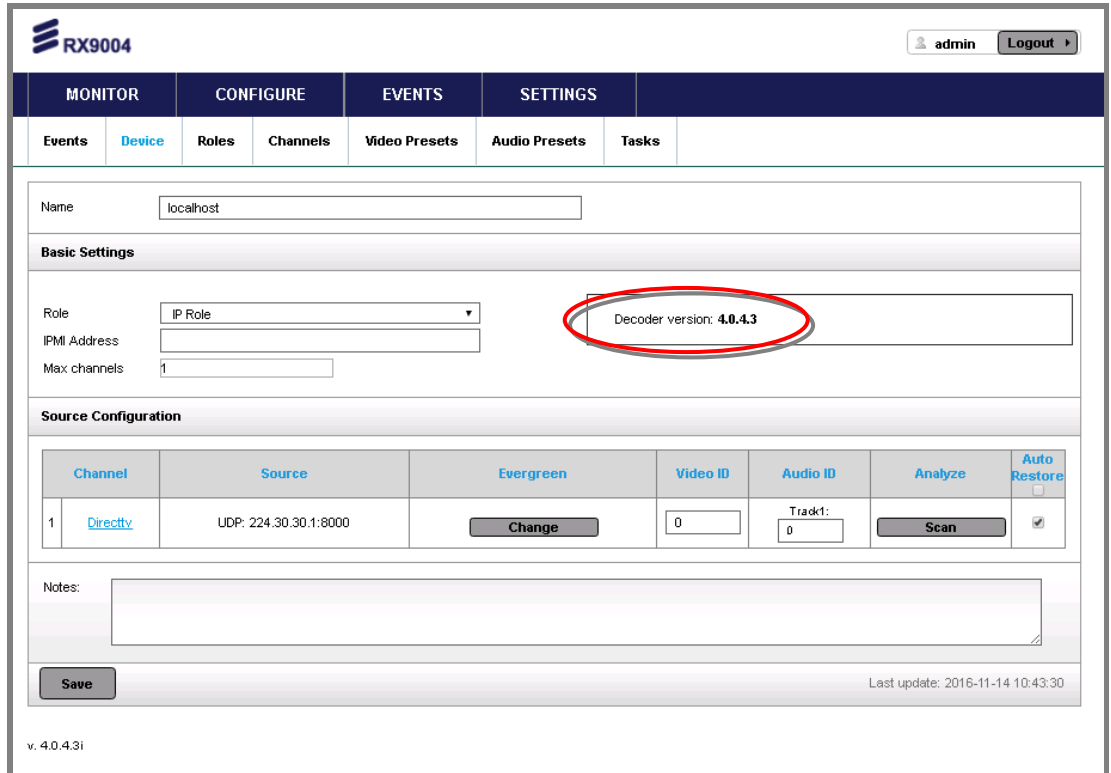

The screenshot shows the RX9004 web GUI interface. At the top, there is a navigation bar with tabs for MONITOR, CONFIGURE, EVENTS, and SETTINGS. The SETTINGS tab is active, and the 'Device' sub-tab is selected. The main content area displays configuration fields for a device named 'localhost'. Under 'Basic Settings', the 'Role' is set to 'IP Role', and the 'Decoder version' is '4.0.4.3', which is circled in red. Below this is the 'Source Configuration' table.

Channel	Source	Evergreen	Video ID	Audio ID	Analyze	Auto Restore
1	Directv UDP: 224.30.30.1:8000	<input type="button" value="Change"/>	<input type="text" value="0"/>	Track1: <input type="text" value="0"/>	<input type="button" value="Scan"/>	<input checked="" type="checkbox"/>

At the bottom, there is a 'Notes' field, a 'Save' button, and a footer indicating 'v. 4.0.4.3i' and 'Last update: 2016-11-14 10:43:30'.

Figure 8.5 Decoder Firmware Version Number

8.7.2 Capturing Management System Log Data

To capture the Management System Log Data:

1. Go to the **SETTINGS** tab on Web GUI
2. Choose the **Maintenance** option.

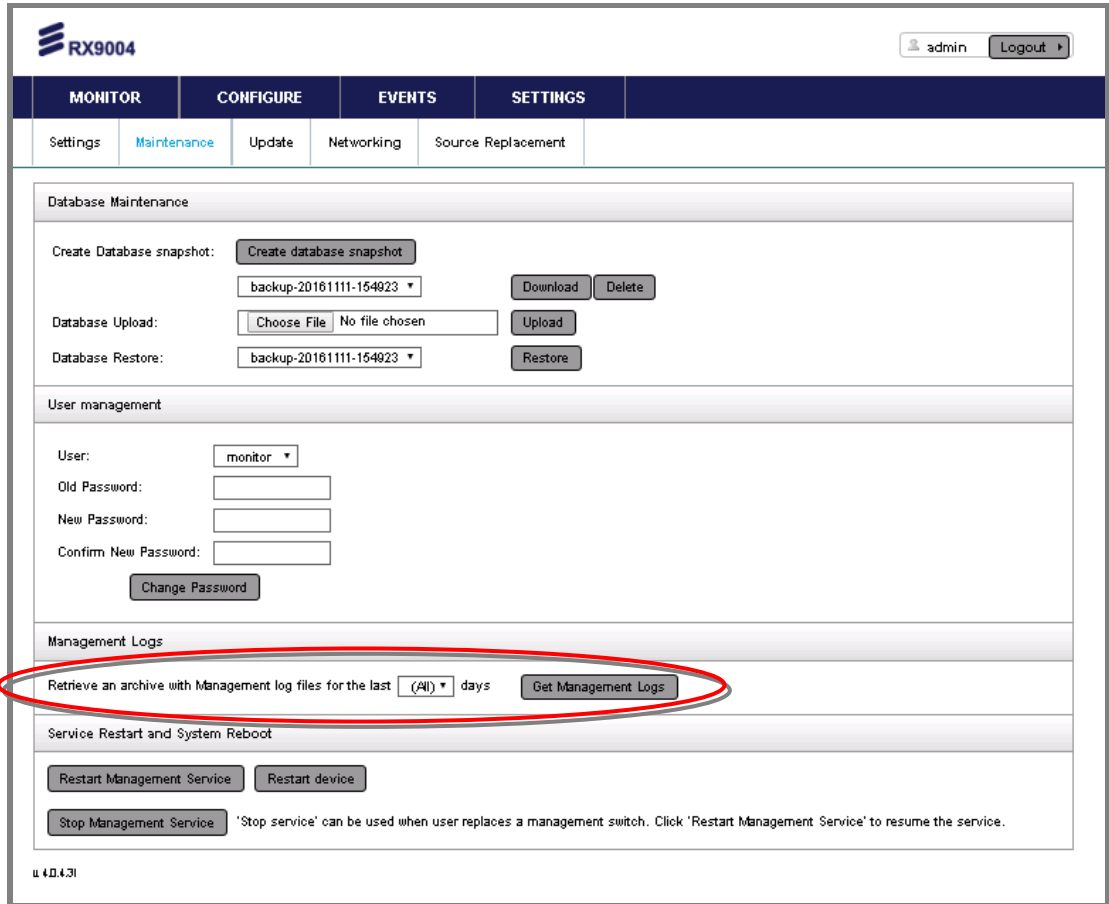

Figure 8.6 Management System Logs

3. Under the **Management Logs** section, select the number of days to capture from the drop-down list and click the **Get Management Logs** button.
4. A download dialog will appear (depending on the Web browser used). Enter the location/name and click **Save** to download the captured logs.

You may choose to capture only a few days of log data, depending upon the timing of the incident being reported.

8.7.3 Capturing Device Log Data

To capture the Device log data:

1. Go to the **MONITOR** tab on HMS Web GUI.
2. Click on the **Admin** link on the top left-hand side of the page.

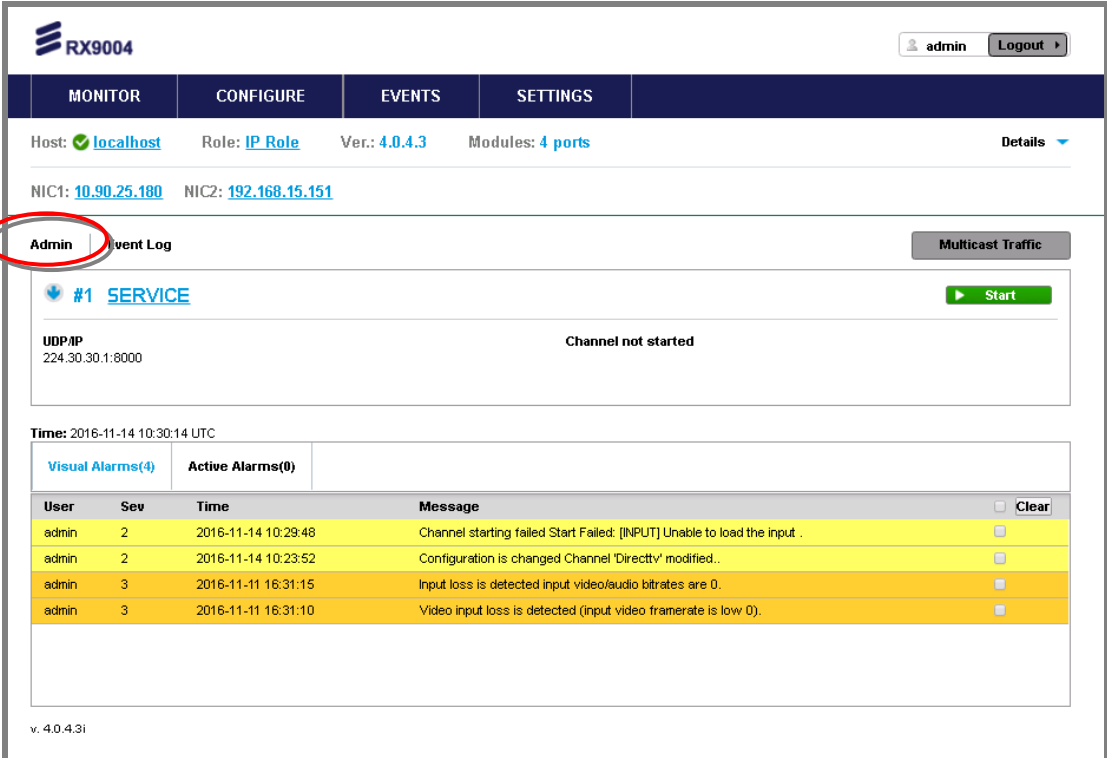

The screenshot shows the RX9004 MONITOR Admin Link interface. The 'Admin' link is circled in red. The interface displays system status (Host: localhost, Role: IP Role, Ver: 4.0.4.3, Modules: 4 ports) and network information (NIC1: 10.90.25.180, NIC2: 192.168.15.151). Below this, there is a service control panel for '#1 SERVICE' with a 'Start' button. A table of Visual Alarms is shown, with the following data:

User	Sev	Time	Message	Clear
admin	2	2016-11-14 10:29:48	Channel starting failed Start Failed: [INPUT] Unable to load the input .	<input type="checkbox"/>
admin	2	2016-11-14 10:23:52	Configuration is changed Channel 'Directv' modified..	<input type="checkbox"/>
admin	3	2016-11-11 16:31:15	Input loss is detected input video/audio bitrates are 0.	<input type="checkbox"/>
admin	3	2016-11-11 16:31:10	Video input loss is detected (input video framerate is low 0).	<input type="checkbox"/>

Figure 8.7 MONITOR Admin Link

3. Under the **Maintenance** section, select the number of days to capture from the drop-down list and press the **Get Logs** button.

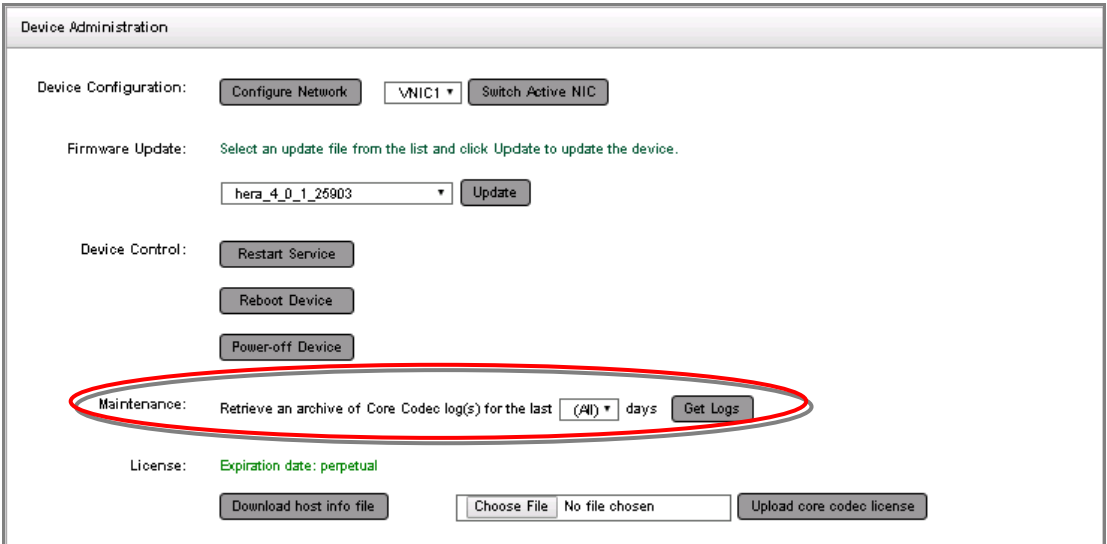

The screenshot shows the Device Administration interface. The 'Maintenance' section is circled in red, showing a dropdown menu for days (set to '(All)') and a 'Get Logs' button. The interface also includes sections for Device Configuration, Firmware Update, Device Control, and License.

Figure 8.8 Device Logs

4. A download dialog will appear (depending on the Web browser used). Enter the location/name and click **Save** to download the captured logs.

You may choose to capture only a few days of log data, depending upon the timing of the incident being reported. Note that log data can be several 100s of MBs big, so it is advised to only capture the needed days and not all of available logs.

8.7.4 Exporting a Channel Configuration File

To export a Channel configuration file:

1. Go to the **MONITOR** tab on Web GUI.
2. Choose the Device (colored box).
3. Then click on the Channel name/link that corresponds to the incident being reported.

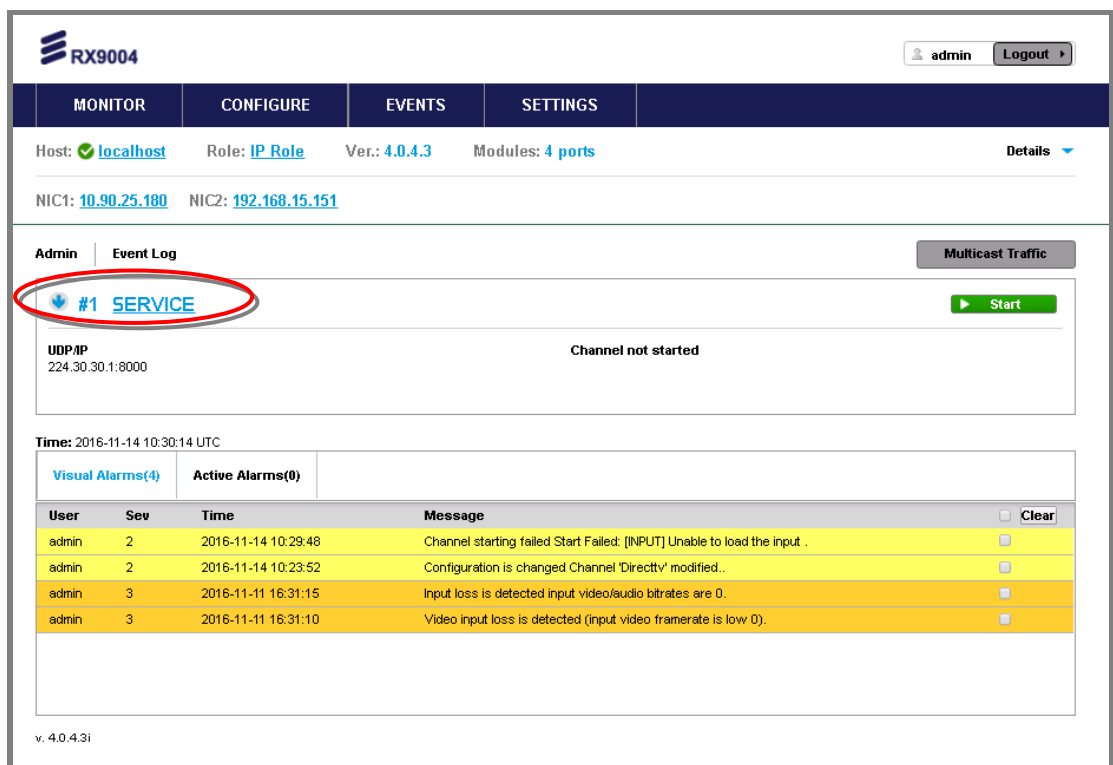

The screenshot shows the RX9004 Web GUI interface. At the top, there are navigation tabs: MONITOR, CONFIGURE, EVENTS, and SETTINGS. The MONITOR tab is selected. Below the tabs, there is a header section with Host: localhost, Role: IP Role, Ver.: 4.0.4.3, and Modules: 4 ports. Below this, there are two NICs listed: NIC1: 10.90.25.180 and NIC2: 192.168.15.151. The main content area is divided into two sections: Admin and Event Log. The Event Log section is active, and a channel named '#1 SERVICE' is highlighted with a red circle. Below the channel name, there is a 'Start' button and the text 'Channel not started'. Below this, there is a table of Visual Alarms(4) with columns for User, Sev, Time, and Message. The table contains four rows of log entries.

User	Sev	Time	Message	Clear
admin	2	2016-11-14 10:29:48	Channel starting failed Start Failed: [INPUT] Unable to load the input .	<input type="checkbox"/>
admin	2	2016-11-14 10:23:52	Configuration is changed Channel 'Directty' modified..	<input type="checkbox"/>
admin	3	2016-11-11 16:31:15	Input loss is detected input video/audio bitrates are 0.	<input type="checkbox"/>
admin	3	2016-11-11 16:31:10	Video input loss is detected (input video framerate is low 0).	<input type="checkbox"/>

Figure 8.9 Channel Selection

4. At the bottom of the Channel Configuration page click the **Export** button save the XML file as prompted.

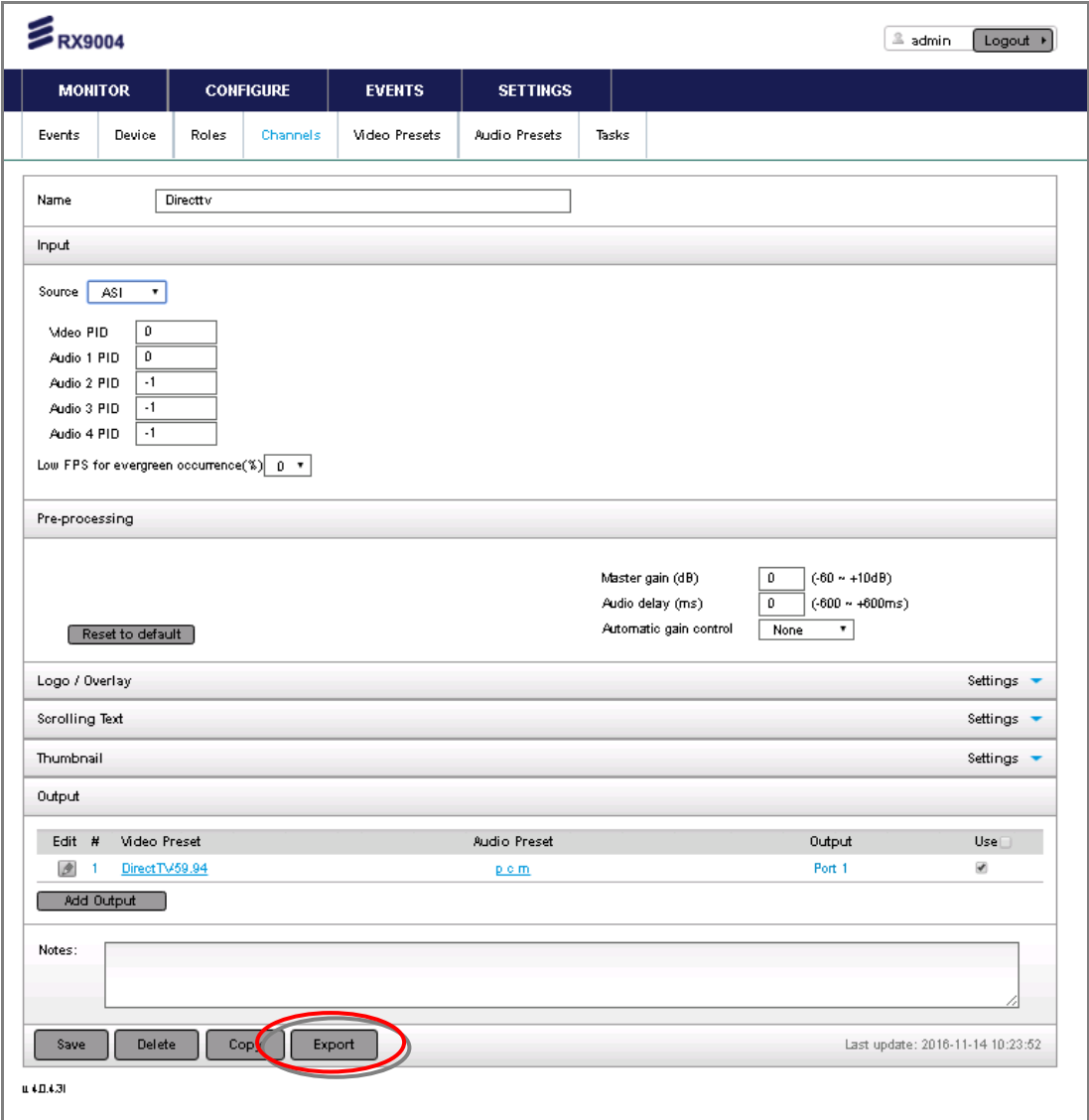

RX9004 admin Logout

MONITOR **CONFIGURE** **EVENTS** **SETTINGS**

Events Device Roles **Channels** Video Presets Audio Presets Tasks

Name: DirectTV

Input

Source: ASI

Video PID: 0
Audio 1 PID: 0
Audio 2 PID: -1
Audio 3 PID: -1
Audio 4 PID: -1

Low FPS for evergreen occurrence(%): 0

Pre-processing

Master gain (dB): 0 (-60 ~ +10dB)
Audio delay (ms): 0 (-600 ~ +600ms)
Automatic gain control: None

Reset to default

Logo / Overlay: Settings
Scrolling Text: Settings
Thumbnail: Settings

Output

Edit	#	Video Preset	Audio Preset	Output	Use
	1	DirectTV59_94	p.e.m.	Port 1	<input checked="" type="checkbox"/>

Add Output

Notes:

Save Delete Copy **Export**

Last update: 2016-11-14 10:23:52

4.0.4.31

Figure 8.10 Export Channel Configuration File



BLANK



Glossary

Annex A

The following list covers most of the abbreviations, acronyms and terms as used in Ericsson Manuals, User and Reference Guides. All terms may not be included in this Reference Guide.

µm	Micrometer (former name - micron): a unit of length equal to one millionth (10^{-6}) of a meter.
1000BaseT	The term for the Electrical Gigabit Ethernet interface. This is the most common interface for Gigabit Ethernet. Most Gigabit-enabled PCs and equipment use this interface.
3:2 pull-down	A technique used when converting film material (which operates at 24 pictures per second) to 525-line video (operating at 30 pictures per second).
4:2:0	Digital video coding method in which the color difference signals are sampled on alternate lines at half the luminance rate.
4:2:2	Digital video coding method in which the color difference signals are sampled on all lines at half the luminance rate.
422P@ML	422 Profile at Main Level: A subset of the MPEG-2 standard, which supports digital video storage (DVD etc.) and transmissions up to 50 Mbps over various mediums. Used for Contribution and Distribution applications.
ABR	Adaptive Bit Rate.
ADPCM	Adaptive Differential Pulse Code Modulation: An advanced PCM technique that converts analogue sound into digital data and vice versa. Instead of coding an absolute measurement at each sample point, it codes the difference between samples and can dynamically switch the coding scale to compensate for variations in amplitude and frequency.
ACC	Authorization Control Computer.
ADT	Audio, Data And Teletext.
AFC	Automatic Frequency Control.
AFS	Automation File Server.
AGC	Automatic Gain Control.

ALC	Automatic Loudness Control: ALC is an audio processing mode for measuring and modifying audio amplitude with the aim of changing the perceived loudness level. It uses a measurement based upon the new standards for measuring audio loudness defined in ITU-R BS.1770-2, this standard forms the measurement basis of the guidelines in EBU R128 and ATSC/A85.
AMOL I and II	Automatic Measure of Line-ups I and II: Used by automated equipment to measure programme-viewing ratings.
ARP	Address Resolution Protocol. A protocol used to "resolve" IP addresses into underlying Ethernet MAC addresses.
ASI	Asynchronous Serial Interface.
ASIC	Application-Specific Integrated Circuit: A customized chip designed to perform a specific function.
Async	Asynchronous.
ATM	Asynchronous Transfer Mode: A connection orientated, cell based, data transport technology designed for Broadband ISDN (B-ISDN). It provides a circuit-switched bandwidth-on-demand carrier system, with the flexibility of packet switching. It offers low end-to-end delays and (negotiable on call set up) Quality of Service guarantees. Asynchronous refers to the sporadic nature of the data being transmitted. Cells are transmitted only when data is to be sent, therefore the time interval between cells varies according to the availability of data.
ATSC	Advanced Television Standards Committee: An organization founded in 1983 to research and develop a digital TV standard for the U.S.A. In late 1996, the FCC adopted the ATSC standard, the digital counterpart of the NTSC standard.
AVC	Advanced Video Coding - see MPEG-4.
AVP	Advanced Video Processor.
B3ZS	Bipolar with Three Zero Substitution: A method of eliminating long zero strings in a transmission. It is used to ensure a sufficient number of transitions to maintain system synchronization when the user data stream contains an insufficient number of 1s to do so. B3ZS is the North American equivalent of the European HDB3.
Backward Compatibility	Refers to hardware or software that is compatible with earlier versions.
BAT	Bouquet Association Table: Part of the service information data. The BAT provides information about bouquets. It gives the name of the bouquet and a list of associated services.
baud rate	The rate of transfer of digital data when the data comprises information symbols that may consist of a number of possible states. Equivalent to bit rate when the symbols only have two states (1 and 0). Measured in Baud.

BER	Bit Error Ratio: A measure of transmission quality. The rate at which errors occur in the transmission of data bits over a link. It is generally shown as a negative exponent, (e.g., 10 ⁻⁷ means that 1 in 10,000,000 bits are in error).
BISS	Basic Interoperable Scrambling System: Non-proprietary encryption from EBU (Tech3290).
Bit rate	The rate of transfer of digital data when the data comprises two logic states, 1 and 0. Measured in bit/s.
Block; Pixel Block	An 8-row by 8-column matrix of luminance sample values, or 64 DCT coefficients (source, quantized, or de-quantized).
Bouquet	A collection of services (TV, radio, and data, or any combination of the three) grouped and sold together, and identified in the SI as a group. A single service may be in several bouquets.
B-Picture; B-Frame	Bi-directionally Predictive Coded Picture/Frame: A picture that is coded using motion-compensated prediction from previous I or P frames (forward prediction) and/or future I or P frames (backward prediction). B frames are not used in any prediction.
BPSK	Binary Phase Shift Keying: A data modulation technique.
Buffer	A memory store used to provide a consistent rate of data flow.
BW	Bandwidth: The transmission capacity of an electronic line such as (among others) a communications network, computer bus, or broadcast link. It is expressed in bits per second, bytes per second or in Hertz (cycles per second). When expressed in Hertz, the frequency may be a greater number than the actual bits per second, because the bandwidth is the difference between the lowest and highest frequencies transmitted. High bandwidth allows fast transmission or high-volume transmission.
Byte-mode	Each byte is delivered separately in the ASI transport stream, with stuffing data added between the Bytes to increase the data rate to 270 Mbps. See DVB Document A010 rev. 1, Section B3.3, (ASI) Layer-2 Transport Protocol.
CA	Conditional Access: The technology used to control the access to viewing services to authorized subscribers through the transmission of encrypted signals and the programmable regulation of their decryption by a system such as viewing cards.
CAT	Conditional Access Table: Part of the MPEG-2 Program Specific Information (PSI) data. Mandatory for MPEG-2 compliance if CA is in use.
C-Band	The portion of the electromagnetic spectrum, which spans the frequency range of approximately 4 GHz to 6 GHz. Used by communications satellites. Preferred in tropical climates because it is not susceptible to fading.
CCIR	See: ITU-R.
CCITT	See: ITU-T.

Channel	<p>a narrow range of frequencies, part of a frequency band, for the transmission of radio and television signals without interference from other channels.</p> <p>In the case of OFDM, a large number of carriers spaced apart at precise frequencies are allocated to a channel.</p>
Channel Coding	<p>A way of encoding data in a communications channel that adds patterns of redundancy into the transmission path in order to improve the error rate. Such methods are widely used in wireless communications.</p>
Chrominance	<p>The color part of a TV picture signal, relating to the hue and saturation but not to the luminance (brightness) of the signal. In a composite-coded color system, the color information (chrominance, often referred to as chroma) is modulated onto a high frequency carrier and added to the monochrome-format video signal carrying the luminance (Y). In a component-coded color system, the two color-difference signals (R-Y)(B-Y) usually referred to as $C_R C_B$ (digital) or $P_R P_B$ (analogue), are used to convey color information. When $C_R C_B$ ($P_R P_B$) is added to the luminance (Y), the complete picture information is conveyed as $Y C_R C_B$ ($Y P_R P_B$).</p>
Closed Captioning	<p>A TV picture subtitling system used with 525-line analogue transmissions.</p>
CODE	<p>Create Once Distribute Everywhere.</p>
Codec	<p>The combination of an Encoder and a complementary Decoder located respectively at the input and output of a transmission path.</p>
COFDM	<p>Coded OFDM: COFDM adds forward error correction to the OFDM transmission consisting of Reed-Solomon (RS) coding followed by convolutional coding to add extra bits to the transmitted signal. This allows a large number of errors at the receive end to be corrected by convolutional (Viterbi) decoding followed by RS decoding.</p>
Composite	<p>CVBS Video Signal, 1 V_{pk-pk}</p>
Compression	<p>Reduction in the number of bits used to represent the same information. For the purposes of a broadcast system, it is the process of reducing digital picture information by discarding redundant portions of information that are not required when reconstituting the picture to produce viewing clarity. Compression allows a higher bite-rate to be transmitted through a given bandwidth.</p>
Compression System	<p>Responsible for compressing and multiplexing the video / audio / data bitstreams, together with the authorization stream. The multiplexed data stream is then ready for transmission.</p>
$C_R C_B$	<p>Digital Color difference signals. These signals, in combination with the luminance signal (Y), define the color and brightness of each picture element (pixel) on a TV line. See: Chrominance</p>
CRC	<p>Cyclic Redundancy Check: A mathematical algorithm that computes a numerical value based on the bits in a block of data. This number is transmitted with the data and the receiver uses this information and the same algorithm to ensure the accurate delivery of data by comparing the results of algorithm and the number received. If a mismatch occurs, an error in transmission is presumed.</p>

CVBS	Chroma Video Burst and Sync: An analogue Video SD resolution signal, such as NTSC or PAL.
dB	Decibels: A ratio of one quantity to another using logarithmic scales to give results related to human aural or visual perception. dB is a ratio whereas dBm, for example, is an absolute value, quoted as a ratio to a fixed point of 0 dBm. 0 dBm is 1 mW at 1 kHz terminated in 600 Ω . 0 dBmV is 1 mV terminated in 75 Ω .
DCE	Data Communications Equipment: Typically a modem. It establishes, maintains and terminates a session on a network but in itself is not the source (originator) or destination (end receiving unit) of signals (e.g. a computer, see DTE). A DCE device may also convert signals to comply with the transmission path (network) format.
DCT	Discrete Cosine Transform: A technique for expressing a waveform as a weighted sum of cosines. Raw video data is not readily compressible. DCT is not in itself a compression technique but is used to process the video data so that it is compressible by an encoder. DCT processes the picture on an 8x8-pixel block basis, converting the data from an uncompressible X Y form (as displayed by an oscilloscope) to a compressible frequency domain form (as displayed by a spectrum analyzer). Can be forward DCT or inverse DCT.
DDS	Direct Digital Synthesiser.
Decoder	The unit containing the electronic circuitry necessary to decode encrypted signals. Some Decoders are separate from the receiver but in satellite TV broadcasting, the term is often used interchangeably as a name for an Integrated Receiver Decoder (IRD). The term IRD, or IRD / Decoder, is usually associated with satellite TV broadcasting while Cable systems are based on Converters or on Set-Top Boxes / Converters.
Decoding Time stamp	A field that may be present in a PES packet header that indicates the time that an access unit is to be decoded in the system target Decoder.
DENG	Digital Electronic News Gathering
DID	Data Identifier.
Differential Coding	Method of coding using the difference between the value of a sample and a predicted value.
DiffServ	Differentiated Services. A mechanism used on layer 3 - e.g. the IP layer - to differentiate between traffic of various types. DiffServ is based on the ToS field and provides a mechanism for the network to give e.g. video traffic higher priority than other traffic (for example Internet traffic).
DIL	Dual In Line: The most common type of package for small and medium scale integrated circuits. The pins hang vertically from the two long sides of the rectangular package, spaced at intervals of 0.1 inch.
DIN	Deutsches Institut für Normung: German Standards Institute.

Downlink	The part of the satellite communications circuit that extends from the satellite to an Earth station.
Downconvert	The process by which the frequency of a broadcast transport stream is shifted to a lower frequency range.
DPCM	Differential Pulse Code Modulation: An audio digitization technique that codes the difference between samples rather than coding an absolute measurement at each sample point.
DSNG	Digital Satellite News-Gathering.
DSP	Digital Signal Processor.
DTE	Data circuit Terminating Equipment: A communications device that originates (is the source) or is the end receiving unit (destination) of signals on a network. It is typically a terminal or computer.
DTH	Direct-To-Home. The term used to describe uninterrupted transmission from the satellite directly to the subscriber, that is, no intermediary cable or terrestrial network utilized.
DTMF	Dual-Tone MultiFrequency
DVB	Digital Video Broadcasting: A European project which has defined transmission standards for digital broadcasting systems using satellite (DVB-S), cable (DVB-C) and terrestrial (DVB-T) medium, created by the EP-DVB group and approved by the ITU. Specifies modulation, error correction, etc. (see EN 300 421 for satellite, EN 300 429 for cable and EN 300 744 for terrestrial).
DVB SI	Digital Video Broadcasting Service Information.
DVB-PI	DVB-Professional Interfaces
DWDM	Dense Wavelength Division Multiplexing. A mechanism to utilize existing fiber with even more bandwidth by adding extra signals using other wavelengths/colors
Earth	Technical Earth: Ensures that all equipment chassis within a rack are at the same potential, usually by connecting a wire between the Technical earth terminal and a suitable point on the rack. This is sometimes known as a Functional earth. Protective Earth: Used for electric shock protection. This is sometimes known as a safety earth.
EBU	European Broadcast Union.
ECM	Entitlement Control Message.
EDI	Ethernet Data Input
EIA	Electronics Industries Association (USA).

EIT	<p>Event Information Table: Equipment: A component of the DVB-Service Information (SI) stream generated within an Encoder, containing information about events or programmes such as event name, start time, duration, etc.</p> <p>System: EIT (Present/Following) contains the name of the current and next event. It may include an optional descriptor (synopsis) giving brief details of content. EIT (Schedule) is used to produce a full EPG. The EIT is the only DVB-SI table, which can be encrypted.</p>
Elementary Stream	A generic term for a coded bitstream, be it video, audio or other.
EMC	Electromagnetic Compatibility.
EMM	Entitlement Management Message.
Encryption	Encoding of a transmission to prevent access without the appropriate decryption equipment and authorization.
EPG	Electronic Programme Guide: On-screen programme listing using thumbnail pictures and/or text.
Ethernet	The most widely used local area network (LAN) defined by the IEEE as the 802.3 standard. Transmission speeds vary according to the configuration. Ethernet uses copper or fiber-optic cables.
ETS	European Telecommunications Standard.
ETSI	European Telecommunications Standards Institute.
FBAS	German for CVBS
FCC	Federal Communications Commission.
FDM	Frequency Division Multiplex: A common communication channel for a number of signals, each with its own allotted frequency.
FEC	Forward Error Correction: A method of catching errors in a transmission. The data is processed through an algorithm that adds extra bits and sends these with the transmitted data. The extra bits are then used at the receiving end to check the accuracy of the transmission and correct any errors.
FFT	Fast Fourier Transformation: A fast algorithm for performing a discrete Fourier transform.
FIFO	First In, First Out: A data structure or hardware buffer from which items are taken out in the same order they were put in. Also known as a shelf from the analogy with pushing items onto one end of a shelf so that they fall off the other. A FIFO is useful for buffering a stream of data between a sender and receiver that are not synchronized - i.e. they not sending and receiving at exactly the same rate.
FM	Frequency Modulation: Analogue modulation procedure
Footprint	The area of the Earth's surface covered by a satellite's downlink transmission. Also (generally) the area from which the satellite can receive uplink transmissions.

FTP	File Transfer Protocol: A protocol used to transfer files over a TCP/IP network (Internet, UNIX, etc.). For example, after developing the HTML pages for a Web site on a local machine, they are typically uploaded to the Web server, using FTP. Unlike e-mail programs in which graphics and program files have to be attached, FTP is designed to handle binary files directly and does not add the overhead of encoding and decoding the data.
G.703	The ITU-T standard which defines the physical and electrical characteristics of hierarchical digital interfaces.
GOP	Group of Pictures: MPEG video compression works more effectively by processing a number of video frames as a block. The Ericsson AB Encoder normally uses a 12 frame GOP; every twelfth frame is an I frame.
GUI	Graphical User Interface: The use of pictures rather than just words to represent the input and output of a program. A program with a GUI runs under a windowing system and has a screen interface capable of displaying graphics in the form of icons, drop-down menus and a movable pointer. The on-screen information is usually controlled / manipulated by a mouse or keyboard.
H.264	ITU-T H.264 which has been incorporated into MPEG-4 Part 10, Advanced Video Coding - see MPEG-4.
HDTV	High Definition Television.
HPA	High Power Amplifier: Used in the signal path to amplify the modulated and up-converted broadcast signal for feeding to the uplink antenna.
HSYNC	Horizontal (line) SYNCs.
HTTP	HyperText Transfer Protocol. The fundamental protocol used on the Internet for transmission of WEB pages and other data between servers and PCs
HU	Height Unit
Hub	A device in a multi-point network at which branch nodes interconnect.
ICAM	Integrated Conditional Access Module: Embedded in the IRD and responsible for descrambling, plus packet filtering and reception. It also contains the physical interface to the subscriber's viewing card.
ICMP	Internet Control Message Protocol. ICMP messages, delivered in IP packets, are used for out-of-band messages related to network operation or mis-operation
IGMP	Internet Group Management Protocol. IGMP is a protocol used to manage multicasts on the Internet. For a host (receiver unit) to receive a multicast, it needs to transmit IGMP "join" messages on the right format. Three versions exist. IGMPv2 is common today but IGMPv3 is the next step.
IDU	Indoor unit
IEC	International Electrotechnical Committee.

IF	Intermediate Frequency: Usually refers to the 70 MHz or 140 MHz output of the Modulator in cable, satellite and terrestrial transmission applications.
Interframe Coding	Compression coding involving consecutive frames. When consecutive frames are compared, temporal redundancy is used to remove common elements (information) and arrive at difference information. MPEG-2 uses B and P frames, but since they are individually incomplete and relate to other adjacent frames, they cannot be edited independently.
Intraframe Coding	Compression coding involving a single frame. Redundant information is removed on a per frame basis. All other frames are ignored. Coding of a macroblock or picture that uses information only from that macroblock or picture. Exploits spatial redundancy by using DCT to produce I frames; these are independent frames and can be edited.
IP	Internet Protocol: The IP part of TCP/IP. IP implements the network layer (layer 3) of the protocol, which contains a network address and is used to route a message to a different network or sub-network. IP accepts packets from the layer 4 transport protocol (TCP or UDP), adds its own header to it and delivers a datagram to the layer 2 data link protocol. It may also break the packet into fragments to support the Maximum Transmission / Transfer Unit (MTU) of the network.
I-picture; I-frame	Intracoded Picture/Frame: A picture / frame, which is coded using purely intracoding with reference to no other field or frame information. The I frame is used as a reference for other compression methods.
IPPV	Impulse Pay Per View: One-time events, purchased at home (on impulse) using a prearranged SMS credit line.
IRD	Integrated Receiver Decoder: The Receiver with an internal MPEG Decoder, which is connected to the subscriber's TV. The IRD is responsible for receiving and de-multiplexing all signals. The unit receives the incoming signal and if CA is active, decodes the signal when provided with a control word by the viewing card. Domestic IRDs are also known as Set-Top Units or Set-Top Boxes.
IRE	Institute of Radio Engineers: No longer in existence but the name lives on as a unit of video amplitude measurement. This unit is 1% of the range between blanking and peak white for a standard amplitude signal.
ISDN	Integrated Services Digital Network: The basic ISDN service is BRI (Basic Rate Interface), which is made up of two 64 kbps B channels and one 16 kbps D channel (2B+D). If both channels are combined into one, called bonding, the total data rate becomes 128 kbps and is four and a half times the bandwidth of a V.34 modem (28.8 kbps). The ISDN high speed service is PRI (Primary Rate Interface). It provides 23 B channels and one 64 kbps D channel (23B+D), which is equivalent to the 24 channels of a T1 line. When several channels are bonded together, high data rates can be achieved. For example, it is common to bond six channels for quality videoconferencing at 384 kbps. In Europe, PRI includes 30 B channels and one D channel, equivalent to an E1 line.

ISO	International Standards Organisation.
ISOG	Inter-union Satellite Operations Group.
ITS	Insertion Test Signal: A suite of analogue test signals placed on lines in the VBI. Also known as VITS.
ITT	Invitation To Tender.
ITU-R	International Telecommunications Union - Radiocommunications Study Groups (was CCIR).
ITU-T	International Telecommunications Union - Telecommunications Standardization Sector (was CCITT).
JPEG	Joint Photographic Experts Group: ISO/ITU standard for compressing still images. It has a high compression capability. Using discrete cosine transform, it provides user specified compression ratios up to around 100:1 (there is a trade-off between image quality and file size).
kbps	1000 bits per second.
Kbit	1024 bits, usually refers to memory capacity or allocation.
Ku-band	The portion of the electromagnetic spectrum, which spans the frequency range of approximately 12 GHz to 14 GHz. Used by communications satellites. Preferred for DTH applications because this range of frequency is less susceptible to interference.
LAN	Local Area Network: A network, which provides facilities for communications within a defined building or group of buildings in close proximity.
L-band	The frequency band from 950 MHz to 2150 MHz, which is the normal input-frequency-range of a domestic IRD. The incoming signal from the satellite is down-converted to L-band by the LNB.
LED	Light Emitting Diode.
LNB	Low Noise Block Down-Converter: The component of a subscriber satellite transmission receiving dish which amplifies the incoming signal and down-converts it to a suitable frequency to input to the IRD (typically 950 MHz - 1600 MHz).
LO	Local Oscillator.
lsb	Least significant bit.
Luminance	The television signal representing brightness, or the amount of light at any point in a picture. The Y in $Y C_R C_B$.
LVDS	Low Voltage Differential Signal: LVDS is a generic multi-purpose Interface standard for high speed / low power data transmission. It was standardized in ANSI/TIA/EIA-644-1995 Standard (aka RS-644).

Macroblock	A 16x16-pixel area of the TV picture. Most processing within the MPEG domain takes place with macro blocks. These are converted to four 8x8 blocks using either frame DCT or field DCT. Four 8 x 8 blocks of luminance data and two (4:2:0 chrominance format), four (4:2:2) or eight (4:4:4) corresponding 8 x 8 blocks of chrominance data coming from a 16 x 16 section of the luminance component of the picture. Macroblock can be used to refer to the sample data and to the coded representation of the sample values and other data elements.
Mbps	Million bits per second.
MCC	Multiplex Control Computer: A component of a System 3000 compression system. The MCC sets up the configuration for the System 3000 Multiplexers under its control. The MCC controls both the main and backup Multiplexer for each transport stream.
MCPC	Multiple Channels Per Carrier.
Meta-data	Meta-data is descriptive data that is "tagged" to a movie or audio clip. Meta-data is essential for the broadcaster.
MMDS	Multichannel Microwave Distribution System: A terrestrial microwave direct-to-home broadcast transmission system.
Motion Compensation	The use of motion vectors to improve the efficiency of the prediction of sample values. The prediction uses motion vectors to provide offsets into the past and/or future reference frames or fields containing previously decoded sample values that are used to form the prediction error signal.
Motion Estimation	The process of estimating motion vectors in the encoding process.
Motion Vector	A two-dimensional vector used for motion compensation that provides an offset from the coordinate position in the current picture or field to the coordinates in a reference frame or field.
MP@ML	Main Profile at Main Level: A subset of the MPEG-2 standard, which supports digital video storage (DVD etc.) and transmissions up to 15 Mbps over various mediums.
MP@HL	Main Profile at High Level: A subset of the MPEG-2 standard, which supports digital video storage (DVD etc.) and transmissions up to 80 Mbps over various mediums.
MPEG	Moving Pictures Experts Group: The name of the ISO/IEC working group which sets up the international standards for digital television source coding.
MPEG-2	Industry standard for video and audio source coding using compression and multiplexing techniques to minimize video signal bit rate in preparation for broadcasting. Specified in ISO/IEC 13818. The standard is split into layers and profiles defining bit rates and picture resolutions.
MPEG-4	Industry standard for video and audio source coding, an improvement over MPEG-2. Specified in ISO/IEC 14496. This product does not necessarily support all parts of the specification.

MPLS	Multi-protocol Label Switching. A Quality of Service mechanism for IP networks that allow IP packets to flow along a predefined path in a network, improving the reliability and robustness of the transmission.
MPM	Media Processing Module.
MPTS	Multi-Program Transport Streams. Transport Streams that carry multiple TV/Radio services.
msb	Most significant bit.
Msymbol/s	(Msym/s) Mega (million) Symbols per second (10^6 Symbols per second).
Multiplex	A number of discrete data streams (typically 8 to 12), from encoders, that are compressed together in a single DVB compliant transport stream for delivery to a Modulator.
Multicast	An IP mechanism that allows transmission of data to multiple receivers. A multicast can also have several transmit sources simultaneously. In video applications, multicast is typically used to distribute a video signal from a central source to multiple destinations.
MUSICAM	Masking pattern adapted Universal Sub-band Integrated Coding And Multiplexing: An audio bit rate reduction system relying on sub-band coding and psychoacoustic masking.
Mux	<p>Multiplexer: Transmission Multiplexer: receives EMMs from the ACC, ECMs from the BCC, video/audio data from the encoders, and the SI stream from the SIC. It then multiplexes them all into a single DVB-compliant transport stream, and delivers the signal to the uplink after modulation.</p> <p>The Multiplexer also contains the cipher card, which scrambles the services according to the control words supplied by the BCC.</p>
Network	In the context of broadcasting: a collection of MPEG-2 transport stream multiplexes transmitted on a single delivery system, for example, all digital channels on a specific cable system.
NICAM	Near Instantaneously Companded Audio Multiplex: Official name is NICAM 728. Used for digital stereo sound broadcasting in the UK employing compression techniques to deliver very near CD quality audio. 728 refers to the bit rate in kbps.
NIT	Network Information Table: Part of the service information data. The NIT provides information about the physical organization of each transport stream multiplex, and the characteristics of the network itself (such as the actual frequencies and modulation being used).
nm	Nanometer: a unit of length equal to one thousand millionth (10^{-9}) of a meter.
NMS	Network Management System. A system used to supervise elements in an IP network. When a device reports an alarm, the alarm will be collected by the NMS and reported to the operator. NMS systems typically collect valuable statistics information about the network performance and can warn the operator early.

NTSC	National Television Systems Committee: The group, which developed analogue standards used in television broadcast systems in the United States. Also adopted in other countries (e.g. Mexico, Canada, Japan). This system uses 525 picture lines and a 59.97 Hz field frequency.
NVOD	Near Video On-Demand: Method of offering multiple showings of movies or events. The showings are timed to start at set intervals, determined by the broadcaster. Each showing of a movie or event can be sold to subscribers separately.
NVRAM	Non-volatile Random Access Memory: Memory devices (permitting random read / write access) that do not lose their information when power is removed. Stores the default configuration parameters set by the user.
ODU	Outdoor Unit
OFDM	Orthogonal Frequency Division Multiplex: A modulation technique used for digital TV transmission in Europe, Japan and Australia; more spectrally efficient than FDM. In OFDM, data is distributed over a large number of carriers spaced apart at precise frequencies. The carriers are arranged with overlapping sidebands in such a way that the signals can be received without adjacent channel interference.
OPPV	Order ahead Pay Per View: An advance purchase of encrypted one-time events with an expiry date.
OSD	On-screen display: Messages and graphics, typically originating from the SMS, and displayed on the subscriber's TV screen by the IRD, to inform the subscriber of problems or instruct the subscriber to contact the SMS.
Packet	A unit of data transmitted over a packet switching network. A packet consists of a header followed by a number of contiguous bytes from an elementary data stream.
PAL	Phase Alternating Line: A color TV broadcasting system where the phase of the R-Y color-difference signal is inverted on every alternate line to average out errors providing consistent color reproduction.
PAT	Program Association Table: Part of the MPEG-2 Program Specific Information (PSI) data and is mandatory for MPEG-2 compliance. The PAT points (maps) to the PMT.
PCM	Pulse Code Modulation: A process in which a signal is sampled, each sample is quantized independently of other samples, and the resulting succession of quantized values is encoded into a digital signal.
PCR	Program Clock Reference: A time stamp in the transport stream from which the Decoder timing is derived.
PDC	Program Delivery Control: A Teletext service allowing simple programming (i.e. VideoPlus) of VCR recording times. If the desired program is rescheduled, PDC updates the programming information in the VCR.

Pel	Picture Element: Also known as a pixel. The smallest resolvable rectangular area of an image either on a screen or stored in memory. On-screen, pixels are made up of one or more dots of color. Monochrome and grey-scale systems use one dot per pixel. For grey-scale, the pixel is energized with different intensities, creating a range from dark to light (a scale of 0-255 for an eight-bit pixel). Color systems use a red, green and blue dot per pixel, each of which is energized to different intensities, creating a range of colors perceived as the mixture of these dots. If all three dots are dark, the result is black. If all three dots are bright, the result is white.
PES	Packetized Elementary Stream: A sequential stream of data bytes that has been converted from original elementary streams of audio and video access units and transported as packets. Each PES packet consists of a header and a payload of variable length and subject to a maximum of 64 kbytes. A time stamp is provided by the MPEG-2 systems layer to ensure correct synchronization between related elementary streams at the Decoder.
PID	Packet Identifier: the header on a packet in an elementary data stream, which identifies that data stream. An MPEG-2 / DVB standard.
PIN	Personal Identification Number: A password used to control access to programming and to set purchase limits. Each subscriber household can activate several PINs and may use them to set individual parental rating or spending limits for each family member.
Pixel	PIX (picture) Element: The digital representation of the smallest area of a television picture capable of being delineated by the bit-stream. See Pel for more information.
pk-pk	peak to peak: Measurement of a signal or waveform from its most negative point to its most positive point.
PLL	Phase-Locked Loop. A phase-locked loop is a control system which controls the rotation of an object by comparing its rotational position (phase) with another rotating object as in the case of a sine wave or other repeating signal. This type of control system can synchronize not only the speed, but also the angular position of two waveforms that are not derived from the same source.
PMT	Program Map Table: Part of the MPEG-2 Program Specific Information (PSI) data and is mandatory for MPEG-2 compliance. Each service has a PMT, which lists the component parts (elementary streams of video, audio, etc.) for the various services being transmitted.
P-picture/P-frame	A picture / frame produced using forward prediction. It contains predictions from either previous I frames or previous P frames. The P frame is used as a reference for future P or B frames.
ppm	Parts per million.
PPV	Pay Per View: A system of payment for viewing services based on a usage / event basis rather than on on-going subscription. Subscribers must purchase viewing rights for each PPV event that they wish to view. PPV events may be purchased as IPPV or OPPV.

Program	PC - A sequence of instructions for a computer. TV - A concept having a precise definition within ISO 13818-1 (MPEG-2). For a transport stream, the timebase is defined by the PCR. The use of the PCR for timing information creates a virtual channel within the stream.
Programme	A linking of one or more events under the control of a broadcaster. For example, football match, news, film show. In the MPEG-2 concept, the collection of elementary streams comprising the programme, have a common start and end time. A series of programmes are referred to as events.
P_RP_B	Analogue Color difference signals. Refer to C _R C _B for an explanation.
PS	Program Stream: A combination of one or more PESs with a common timebase.
PSI	Program Specific Information: Consists of normative data, which is necessary for the de-multiplexing of transport streams and the successful regeneration of programs (see also: SI).
PSIP	Program System Information Protocol: The ATSC equivalent of SI for DVB.
PSK	Phase Shift Keying: A method of modulating digital signals particularly suited to satellite transmission.
PSR	Professional Satellite Receiver: See also: IRD.
PSU	Power Supply Unit.
QAM	Quadrature Amplitude Modulation: A method of modulating digital signals, which uses combined techniques of phase modulation and amplitude modulation. It is particularly suited to cable networks.
QoS	Quality of Service. A common term for a set of parameters describing the quality you get from an IP network: Throughput, availability, delay, jitter and packet loss.
QPSK	Quadrature Phase Shift Keying: A form of phase shift keying modulation using four states.
QSIF	Quarter Screen Image Format.
Quantise	A process of converting analogue waveforms to digital information. 8-bit quantization as set out in ITU-R Rec. 601. Uses 256 levels in the range 0 – 255 to determine the analogue waveform value at any given point. The value is then converted to a digital number for processing in the digital domain.
RAM	Random Access Memory: A volatile storage device for digital data. Data may be written to, or read from, the device as often as required. When power is removed, the data it contains is lost.
RAS	Remote Authorization System: A Ericsson AB proprietary public-key encryption system used to prevent unauthorized viewing of a TV programme or programmes.

Reflex™	<p>An Ericsson AB proprietary system to provide efficient use of bandwidth by a set of encoders without sacrificing picture quality. A group bit rate is allocated to a set of Encoders and the bit rate for each encoder is allocated according to the requirements of the picture encoding process.</p> <p>The bit rate allocation can be performed externally by a multiplexer, or internally in a unit fitted with multiple VCM's.</p>
RF	Radio Frequency.
RGB	Red, Green, Blue: The Chroma information in a video signal.
RIP2	Routing Information Protocol v2. A protocol used between network routers to exchange routing tables and information.
ROM	Read Only Memory: A non-volatile storage device for digital data. Data has been stored permanently in this device. No further information may be stored (written) there and the data it holds cannot be erased. Data may be read as often as required.
RS	Reed-Solomon coding: An error detection and correction, coding system. 16 bytes of Reed-Solomon Forward Error Correction code are appended to the packet before transmission bringing the packet length to 204 bytes. The 16 bytes are used at the receiving end to correct any errors. Up to eight corrupted bytes can be corrected.
RSVP	ReSerVation Protocol. A Quality-of-service oriented protocol used by network elements to reserve capacity in an IP network before a transmission takes place.
RTP	Real-time Transfer Protocol. A protocol designed for transmission of real-time data like video and audio over IP networks. RTP is used for most video over IP transmissions.
RLC	Run Length Coding: Minimization of the length of a bit-stream by replacing repeated characters with an instruction of the form 'repeat character x y times'.
SBR	Spectral Band Replication.
SCPC	Single Channel Per Carrier.
Spectral Scrambling	A process (in digital transmission) used to combine a digital signal with a pseudo-random sequence, producing a randomized digital signal that conveys the original information in a form optimized for a broadcast channel.
Scrambling	Alteration of the characteristics of a television signal in order to prevent unauthorized reception of the information in clear form.
SDI	Serial Digital Interface.
SDT	Service Description Table: Provides information in the SI stream about the services in the system; for example, the name of the service, the service provider, etc.

SDTI	Serial Data Transport Interface. A mechanism that allows transmission of various types of data over an SDI signal. This may be one or more compressed video signals or other proprietary data types. The advantage of SDTI is that existing SDI transmission infrastructure can be used to transport other types of data.
SELV	Safety Extra Low Voltage (EN 60950).
SFP	Small Form-factor Pluggable module. A standardized mechanism to allow usage of various optical interfaces for Gigabit Ethernet. Several types of SFP modules exist: Single-mode fiber modules for long-distance transmission and multi-mode fiber modules for shorter distances. SFP is also known as "mini-GBIC".
SIP	Session Initiation Protocol. A common acronym for the ongoing effort to standardize signaling over IP networks, i.e. connection set-up and tear-down. SIP makes it possible to "dial" a remote receiver of data and set-up the connection in this way.
STB	Set-Top Box: A box that sits on top of a television set and is the interface between the home television and the cable TV company. New technologies evolving for set-top boxes are video-on-demand, video games, educational services, database searches, and home shopping. The cable equivalent of the IRD.
SFN	Single Frequency Network: The SFN technique allows large geographic areas to be served with a common transmission multiplex. All transmitters in the network are synchronously modulated with the same signal and they all radiate on the same frequency. Due to the multi-path capability of the multi-carrier transmission system (COFDM), signals from several transmitters arriving at a receiving antenna may contribute constructively to the total wanted signal. The SFN technique is not only frequency efficient but also power efficient because fades in the field strength of one transmitter may be filled by another transmitter.
SI	Service Information: Digital information describing the delivery system, content and scheduling (timing) of broadcast data streams. DVB-SI data provides information to enable the IRD to automatically demultiplex and decode the various streams of programmes within the multiplex. Specified in ISO/IEC 13818[1]. (DVB)
Single Packet Burst Mode	A burst of ASI bytes (either 188 or 204, depending on packet length) is contiguously grouped into an MPEG-2 transport stream packet. Stuffing data is added between the packets to increase the data rate to 270 Mbps. See DVB Document A010 rev. 1, Section B3.3, (ASI) Layer-2 Transport Protocol.
Smart Card	A plastic card with a built-in microprocessor and memory used for identification, financial transactions or other authorizing data transfer. When inserted into a reader, data is transferred to and from the host machine or a central computer. It is more secure than a magnetic stripe card and it can be disabled if the wrong password is entered too many times. As a financial transaction card, it can be loaded with digital money and used in the same way as cash until the balance reaches zero. The file protocol is specific to its intended application.

SMATV	Satellite Mast Antenna Television: A distribution system, which provides sound and television signals to the households of a building or group of buildings, typically used to refer to an apartment block.
SMPTE	Society of Motion Picture and Television Engineers.
SMS	Subscriber Management System: A system which handles the maintenance, billing, control and general supervision of subscribers to conditional access technology viewing services provided through cable and satellite broadcasting. An SMS can be an automatic (e.g. Syntellect) system where subscribers order entitlements by entering information via a telephone. Alternatively, an SMS can be a manual system, which requires subscribers to speak with an operator who then manually enters their entitlement requests. Some systems support multiple SMSs.
SNG	Satellite News-Gathering.
SNMP	Simple Network Management Protocol.
SNTP	Simple Network Time Protocol is an Internet protocol used to synchronize the clocks of computers to some time reference. It is a simplified version of the protocol NTP protocol which is too complicated for many systems.
Spatial Redundancy	Information repetition due to areas of similar luminance and/or chrominance characteristics within a single frame. Removed using DCT and Quantization (Intra-Frame Coding).
SPI	Synchronous Parallel Interface.
Statistical Redundancy	Data tables are used to assign fewer bits to the most commonly occurring events, thereby reducing the overall bit rate. Removed using Run Length Coding and Variable Length Coding.
TCP / IP	Transmission Control Protocol/Internet Protocol: A set of communications protocols that may be used to connect different types of computers over networks.
TDM	Time Division Multiplex: One common, communications channel carrying a number of signals, each with its own allotted time slot.
TDT	Time and Date Table: Part of the DVB Service Information. The TDT gives information relating to the present time and date.
Temporal Redundancy	Information repetition due to areas of little or no movement between successive frames. Removed using motion estimation and compensation (Inter-Frame Coding).
Time stamp	A term that indicates the time of a specific action such as the arrival of a byte or the presentation of a presentation unit.
TNS	Temporal Noise Shaping.
TOT	Time Offset Table: This optional SI table supports the use of local offsets as well as the UTC time/date combination. The purpose of the table is to list by country the current offset from UTC and the next expected change to that offset (to track when daylight saving occurs). The offset resolution is to within 1 minute over a range of ± 12 hours from UTC.

Transport Stream	A set of packetized elementary data streams and SI streams, which may comprise more than one programme, but with common synchronization and error protection. The data structure is defined in ISO/IEC 13818-1 [1] and is the basis of the ETSI Digital Video Broadcasting standards.
Transport Stream Packet Header	A data structure used to convey information about the transport stream payload.
TS	Transport Stream.
TSDT	Transport Stream Descriptor Table: A component of the MPEG-2 PSI data. This table describes which type of Transport stream it is in (i.e. DVB, ATSC etc.). It may also contain other descriptors.
TSP	Transport Stream Processor.
U	44.45 mm (rack height standard).
UART	Universal Asynchronous Receiver Transmitter: A device providing a serial interface for transmitting and receiving data.
UDP	User Datagram Protocol. A protocol above the IP layer that provides port multiplexing in addition. In essence, you can transmit IP data packets to several receiving processes in the same unit/device.
Unicast	Point-to-point connection, i.e. the "opposite" of multicast which is one to many (or many to many). In this mode, a transmit unit sends video data direct to a unique destination address.
Upconvert	The process by which the frequency of a broadcast transport stream is shifted to a higher frequency range.
Uplink	The part of the communications satellite circuit that extends from the Earth to the satellite.
UPS	Uninterruptable Power Supply: A method of supplying backup power when the electrical power fails or drops to an unacceptable voltage level. Small UPS systems provide battery power for a few minutes; enough to power down the computer in an orderly manner. This is particularly important where write back cache is used. Write back cache is where modified data intended for the disk is temporarily stored in RAM and can be lost in the event of a power failure. Sophisticated systems are tied to electrical generators that can provide power for days. UPS systems typically provide surge suppression and may provide voltage regulation.
UTC	Universal Time Coordinated: The Coordinated Universal Time synonymous with Greenwich Mean Time (GMT).
VCM	Video Compression Module.
VITC	Vertical Interval Time Code.
VITS	Vertical Interval Test Signal: See: ITS.
VLAN	Virtual LAN, a network of units that behave as if they are connected to the same wire even though they may actually be physically located on different segments of a LAN.
VPS	Video Programming System: A German precursor to PDC



WSS	Wide Screen Switching: Data used in wide-screen analogue services, which enables a receiver to select the appropriate picture display mode.
WST	World System Teletext: System B Teletext. Used in 625 line / 50 Hz television systems (ITU-R 653).
XLR	Audio connector featuring three leads, two for signal and one for GND.
XML	eXtensible Markup Language. A very common self-describing text-based data format. Used for many purposes: Meta-data, configuration files, documents, etc. The readability of the format has made it very popular and is now the fundament for many types of WEB services.
XPO	The name given to the second generation Ericsson standard for web pages and additional supporting interfaces.
Y (Luminance)	Defines the brightness of a particular point on a TV line. The only signal required for black and white pictures.
Y/C	Broadcast video with separate color, Y (luminance) and C (Chroma) (sometimes called S-Video).
YUV	Y: Luminance component (Brightness), U and V: Chrominance (Color difference)



Technical Specification

Annex B

Contents

B.1	Other Specification	B-3
B.2	DCA-2154 Option Card Specification	B-3
B.2.1	General Specification	B-3
B.2.2	Supported Video Formats.....	B-3
B.3	DCA-2174 Option Card Specification	B-4
B.3.1	General Specification	B-4
B.3.2	Supported Video Formats.....	B-4
B.4	Chassis Connectors	B-5
B.5	Physical.....	B-5
B.6	Power Supply	B-5
B.7	Environmental	B-5

List of Tables

Table B.1	DCA-2154 General Specification	B-3
Table B.2	DCA-2154 Supported Video Formats	B-3
Table B.3	DCA-2174 General Specification	B-4
Table B.4	DCA-2174 Supported Video Formats	B-4
Table B.5	Chassis Connector Specification	B-5
Table B.6	Chassis Physical Specification	B-5
Table B.7	Chassis Power Supply Specification.....	B-5
Table B.8	Environmental Specification	B-6



BLANK

B.1 Other Specification

B.2 DCA-2154 Option Card Specification

B.2.1 General Specification

The DCA-2154 has the following general specification.

Table B.1 DCA-2154 General Specification

Parameter	Value
Physical layer	DVB-ASI : EN50083-9 SD-SDI : SMPTE 259M HD-SDI : SMPTE 292M
Connectors	5x 75 Ω 1.0/2.3 DIN
Return loss	≥ 12 dB @ 0 to 1.5 GHz
Matrix API features	8/10/16-bit conversion Audio/video/ANC extraction Hardware scaling: 1/4 or 1/16 Multiple stream synchronisation
PCI Express	PCIe3 x4 low profile
OS	XP, Vista, 2k8, Win7, Win8 Linux $\geq 2.6.18$, 3.x

B.2.2 Supported Video Formats

The DCA-2154 supports the following video formats.

Table B.2 DCA-2154 Supported Video Formats

Parameter	Value
Video format	525i, 625i 720p23.98/24/25/29.97/30/50/59.94/60 1080p(sf)23.98/24/25/29.97/30 1080i50/59.94/60

B.3 DCA-2174 Option Card Specification

B.3.1 General Specification

The DCA-2174 has the following general specification.

Table B.3 DCA-2174 General Specification

Parameter	Value
Physical layer	DVB-ASI : EN50083-9 SD-SDI : SMPTE 259M HD-SDI : SMPTE 292M 3G-SDI : SMPTE 424M
4K multi-link	SMPTE 425-5 quad 3G-link, with support for Annex B
Connectors	5x 75 Ω 1.0/2.3 DIN
Return loss	≥ 12 dB @ 0 to 3 GHz
DekTec Matrix API	8/10/16-bit conversion Audio/video/ANC extraction Hardware scaling: 1/4 or 1/16
PCI Express	PCIe3 x4 low profile
OS	XP, Vista, 2k8, Win7, Win8 Linux $\geq 2.6.18$, 3.x

B.3.2 Supported Video Formats

The DCA-2174 supports the following video formats.

Table B.4 DCA-2174 Supported Video Formats

Parameter	Value
Video format	525i, 625i 720p23.98/24/25/29.97/30/50/59.94/60 1080p(sf)23.98/24/25/29.97/30 1080i50/59.94/60 1080p50/59.94/60 2160p50/59.94/60

B.4 Chassis Connectors

The chassis has the following connector specification.

Table B.5 Chassis Connector Specification

Item	Specification
Gigabit Ethernet	RJ45 ports (up to 6)
BNC ports	75Ω (up to 4) for 12G/3G/HD/SD-SDI (SMPTE 259M 625/525, SMPTE 292M) with embedded audio

B.5 Physical

The chassis has the following physical specification.

Table B.6 Chassis Physical Specification

Item	Specification
Rack	Steel chassis
Height	1U (44 mm)
Width	19" (482.6 mm)
Depth	28.2" (716 mm) or 23.5" (597 mm) (depending upon configuration)
Weight	38 lbs (17.2 kg)

B.6 Power Supply

The chassis, without option cards fitted, does not exceed the following total power requirements.

Table B.7 Chassis Power Supply Specification

Item	Specification
Power Supply	90-264 VAC / 47- 63 Hz, auto-switching
Power Consumption	1400 W

B.7 Environmental

The RX9004 is for use in non-hostile environments, (i.e. designed for indoor use only with no protection against dust or water ingress).

*Table B.8 Environmental Specification*

Item	Specification
Operating Temperature	0 to 50° C, 32 to 122° F
Storage Temperature	-20 to 65° C, -5 to 150° F
Humidity	8% to 90% (non-condensing)
Cooling System	Chassis: 2 x 40x40 mm fans CPU: 1 x 60x60 mm fan Power Supply: 2 x 40x40 mm fan
Handling Movement	Designed for stationary or fixed use when in operation
Shock	10G / 11ms in all axis
Vibration	0.8G / -304.8 m to 3,048 m (-1,000 ft to 10,000+ ft) 5 to 100 Hz
Operating Altitude	-304.8 m to 3,048 m (-1,000 ft to 10,000+ ft)
Non-operating Altitude	-304.8 m to 12,192 m (-1000 ft to 40,000+ ft)

The product requires no special handling or packaging other than normal procedures for Ericsson equipment and is suitable for lifting by one person.



Compliance

Annex C

Contents

C.1	Something	C-3
C.2	Compliance	C-3
C.2.1	Safety	C-3
C.2.2	EMC	C-4
C.2.3	Telecommunications.....	C-4
C.2.4	CE Marking	C-4
C.2.5	C-Tick Mark	C-5
C.2.6	Packaging Statement	C-5
C.2.7	Packaging Markings	C-5
C.2.8	Materials Declarations	C-6
C.2.8.1	For the European Union	C-6
C.2.8.2	For China	C-6
C.2.9	Equipment Disposal.....	C-7
C.2.9.1	General	C-7
C.2.9.2	For the European Union	C-7
C.2.10	Lithium Batteries.....	C-7
C.2.11	Recycling.....	C-7

List of Figures

No table of figures entries found.

BLANK

C.1 Something

C.2 Compliance¹

C.2.1 Safety

This equipment has been designed and tested to meet the requirements of the following:

EN 60950-1	European	Information technology equipment - Safety.
IEC 60950-1	International	Information technology equipment - Safety.
UL 60950-1	USA	Information technology equipment - Safety.

UE 73/23/EEC, EN60950: 2000, UL, CUL, TUV

¹ The version of the standards shown is that applicable at the time of manufacture.

C.2.2 EMC²

The equipment has been designed and tested to meet the following:

EN 55022 and CISPR22	European International	Emission Standard Limits and methods of measurement of radio frequency interference characteristics of information technology equipment - Class A.
EN 61000-3-2 ³	European	Electromagnetic Compatibility (EMC), Part 3 Limits; Section 2. Limits for harmonic current emissions (equipment input current \leq 16 A per phase).
EN 61000-3-3 ³	European	Electromagnetic Compatibility (EMC), Part 3. Limits; Section 3. Limitation of voltage fluctuations and flicker in low voltage supply systems for equipment with rated current \leq 16 A.
EN 55024	European	Information technology equipment - Immunity characteristics - Limits and methods of measurement.
FCC	USA	Conducted and radiated emission limits for a Class A digital device, pursuant to the Code of Federal Regulations (CFR) Title 47-Telecommunications, Part 15: Radio frequency devices, subpart B - Unintentional Radiators.

FCC Class A, CE compliance, UE 89/336/EEC

EN61000-6-2, EN55022, EN55024

C.2.3 Telecommunications

If certain Option Modules (telecom interfaces) are fitted, this equipment comes within the scope of the RTTE Directive, 1999/5/EC. Compliance with the applicable essential requirements of this Directive (safety and EMC) are met by conformance with the safety and EMC standards listed above.

C.2.4 CE Marking



The CE mark is affixed to indicate compliance with the following directives:

DIRECTIVE 2006/95/EC OF THE EUROPEAN PARLIAMENT AND OF THE
COUNCIL of 12 December 2006 on the harmonisation of the laws of Member

² The EMC tests were performed with the Technical Earth attached, and configured using recommended cables).

³ Applies only to models of the Product using AC power sources.

States relating to electrical equipment designed for use within certain voltage limits.

DIRECTIVE 2004/108/EC OF THE EUROPEAN PARLIAMENT AND OF THE COUNCIL of 15 December 2004 on the approximation of the laws of the Member States relating to electromagnetic compatibility

1999/5/EC of 9 March 1999 on radio equipment and telecommunications terminal equipment and the mutual recognition of their conformity. (If fitted with telecom type interface modules).

Note: The CE mark was first affixed to this product in 2012.

C.2.5

C-Tick Mark



The C-Tick mark is affixed to denote compliance with the Australian Radiocommunications (Compliance and Labelling – Incidental Emissions) Notice made under s.182 of Radiocommunications Act 1992.

Note: The C-Tick mark was first affixed to this product in 2012.

C.2.6

Packaging Statement

The outer carton and any cardboard inserts are made from 82% recycled material and are fully recyclable.

C.2.7

Packaging Markings

The symbols printed on the outer carton are described below:



Handle with care.



This way up.



Fragile.



Protect from moisture.



See *B.7.4* for compliance with directives details.



See *B.7.5* for compliance details.



Defines country of origin.



The packaging is reusable per GB 18455-2001.



This symbol guarantees that packaging with this symbol is recyclable and will be accepted by cardboard recyclers.



Recyclable per GB 18455-2001.

C.2.8 Materials Declarations

Ericsson's products are designed and manufactured in keeping with good environmental practise. Our component and materials selection policy prohibits the use of a range of potentially hazardous materials. In addition, we comply with relevant environmental legislation.

C.2.8.1 For the European Union

For products sold into the EU after 1st July 2006, we comply with the EU RoHS Directive. We also comply with the WEEE Directive.

C.2.8.2 For China

For product sold into China after 1st March 2007, we comply with the "Administrative Measure on the Control of Pollution by Electronic Information Products". In the first stage of this legislation, content of six hazardous materials has to be declared together with a statement of the "Environmentally Friendly Use Period (EFUP)": the time the product can be used in normal service life without leaking the hazardous materials. Ericsson expects the normal use environment to be in an equipment room at controlled temperatures (around 22°C) with moderate humidity (around 60%) and clean air, near sea level, not subject to vibration or shock.

Where an Ericsson product contains potentially hazardous materials, this is indicated on the product by the appropriate symbol containing the EFUP. For Ericsson products, the hazardous material content is limited to lead (Pb) in some solders. This is extremely stable in normal use and the EFUP is taken as 50 years, by comparison with the EFUP given for Digital Exchange/Switching Platform in equipment in Appendix A of "General Rule of Environment-Friendly Use Period of Electronic Information Products". This is indicated by the product marking:



It is assumed that while the product is in normal use, any batteries associated with real-time clocks or battery-backed RAM will be replaced at the regular intervals.

The EFUP relates only to the environmental impact of the product in normal use, it does not imply that the product will continue to be supported for 50 years.

C.2.9 Equipment Disposal

C.2.9.1 General

Dispose of this equipment safely at the end of its life. Local codes and/or environmental restrictions may affect its disposal. Regulations, policies and/or environmental restrictions differ throughout the world. Contact your local jurisdiction or local authority for specific advice on disposal.

C.2.9.2 For the European Union



"This product is subject to the EU Directive 2002/96/EC on Waste Electrical and Electronic Equipment (WEEE) and should not be disposed of as unsorted municipal waste."

C.2.10 Lithium Batteries

The equipment uses the Dallas Semiconductor NVRAM DS1746WP which contains a Dallas DS9034PCX Power Cap Lithium battery. This cell is not a USA Environmental Protection Agency listed hazardous waste. It is fully encapsulated and should not be tampered with.

C.2.11 Recycling

Ericsson SA TV Recycling has a process facility that enables customers to return Old and End-of-Life Products for recycling if it is required.

Ericsson provides assistance to customers and recyclers through our Ericsson and SATV Recycling eBusiness Portal.

This can be reached at: <https://ebusiness.ericsson.net/>.

To gain access to the Recycling site, you must be set up with a unique login and password.

To request the login, please contact tvtechpubs@ericsson.com, and include the information below:

- First/Last name
- Password request (6 numbers/characters). If you do not include this information one will be created for you.
- Phone
- Location (Country)
- Company
- Work Area (select one of the below)
 - Executive Management
 - Marketing and Sales
 - Planning/Engineering
 - Procurement/Supply
 - Project & Programme
 - Implementation
 - Operations and Maintenance
 - R&D
 - Other



Replace Source Automation

Annex D

Contents

D.1	Dynamic Source Replacement	D-3
D.2	Architecture - Usage.....	D-3

List of Figures

Figure D.1: Image Replacement Dialog	D-4
--	-----



BLANK

D.1 Dynamic Source Replacement

RX9004's management system allows for the dynamic replacement of live source/feeds with static images or playlists. This is to facilitate block-out periods where the carrier has not acquired the rights for broadcasting a specific program/event. Further, this feature can be used for advertisement purposes. The paragraphs below present how this can be done using a simple HTTP GET based automation. More detailed control over this functionality is provided by the SOAP and REST APIs, contact your Ericsson Representative for access to the API documentation.

D.2 Architecture - Usage

The automation is available over HTTP GET and uses the following syntax:

```
http://<IP_address>/replacesource.php?  
channelname=<channel_name>&  
op=replacesource | restoresource&  
selectedimage=<image_filename>
```

Where:

- `IP_address`: is the IP address of the RX9004 Management System
- `channel_name`: is the exact name of the channel that needs to have the source replaced. Use the **CONFIGURATION** tab and navigate to Channels list view for a list of all the available channels and their respective names.
- `replacesource`: indicates that the live source is to be replaced with a static image.
- `restoresource`: indicates that the channel is to be restored to the live source.
- `image_filename`: is the exact filename of the blank-out image. Use the **SETTINGS** tab and navigate to **Image Upload** dialog to upload an image.

Return values:

- `Invalid channel`: Channel name is not found.
- `Operation failed`: Channel not currently running or invalid image filename.
- `Operation succeeded`: Operation completed successfully.

Examples:

- Replace the live source of channel "ch_BBC1" with the image unavailable.png

```
http://192.168.1.2/replacesource.php?channelname=ch_BBC1&op=replace  
source&selectedimage=unavailable.png
```

- Restore channel "ch_BBC1" to the original live source

http://192.168.1.2/replacesource.php?channelname=ch_BBC1&op=restoresource

Remarks:

- Both `channel_name` and `image_filename` should be properly encoded for HTTP GET requests.
- Replace and restore requests should not be executed immediately one after the other on the same channel. Allow at least 5 seconds between those requests and ensure each operation is completed successfully before issuing the next one.

Integration:

- Typically, this automation is to be integrated with an Electronic Program Guide (EPG) or middleware that keeps track of block-out periods for each channel.
- The automation can be initiated manually, using the **Replace Source** link in the **Device/Channel Monitor** page. The related dialog is shown below.

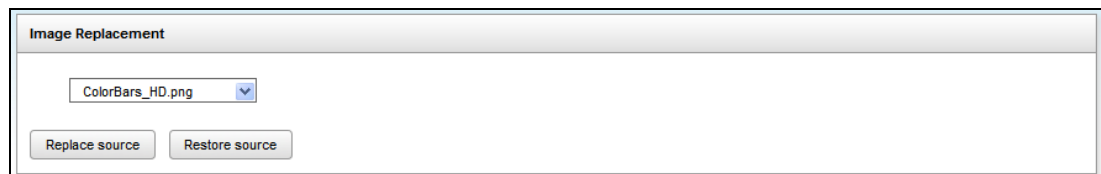

Figure D.1: Image Replacement Dialog



Network Configuration

Annex E

Contents

E.1	Netconfig	E-3
E.2	NIC Tab.....	E-3
E.3	Advanced Tab	E-4
E.4	VLAN Tab.....	E-5

List of Figures

Figure E.1	NIC Configuration Tab.....	E-3
Figure E.2	Advanced Network Configuration Tab	E-4
Figure E.3	NIC Tab with an Additional (Virtual) NIC.....	E-5
Figure E.4	Virtual LAN Configuration Tab	E-5



BLANK

E.1 Netconfig

The purpose of this Annex is to provide additional information and guidance regarding the configuration of the network for RX9004 Devices.

The network configuration interface (netconfig) is available at:

http://<HERO_IP>/hera/netconfig/

E.g.: <http://10.0.0.162/hera/netconfig/>

E.2 NIC Tab

The initial tab ('NIC') presents the available Ethernet interfaces and a summary of their configuration. To modify the configuration press **Configure**.

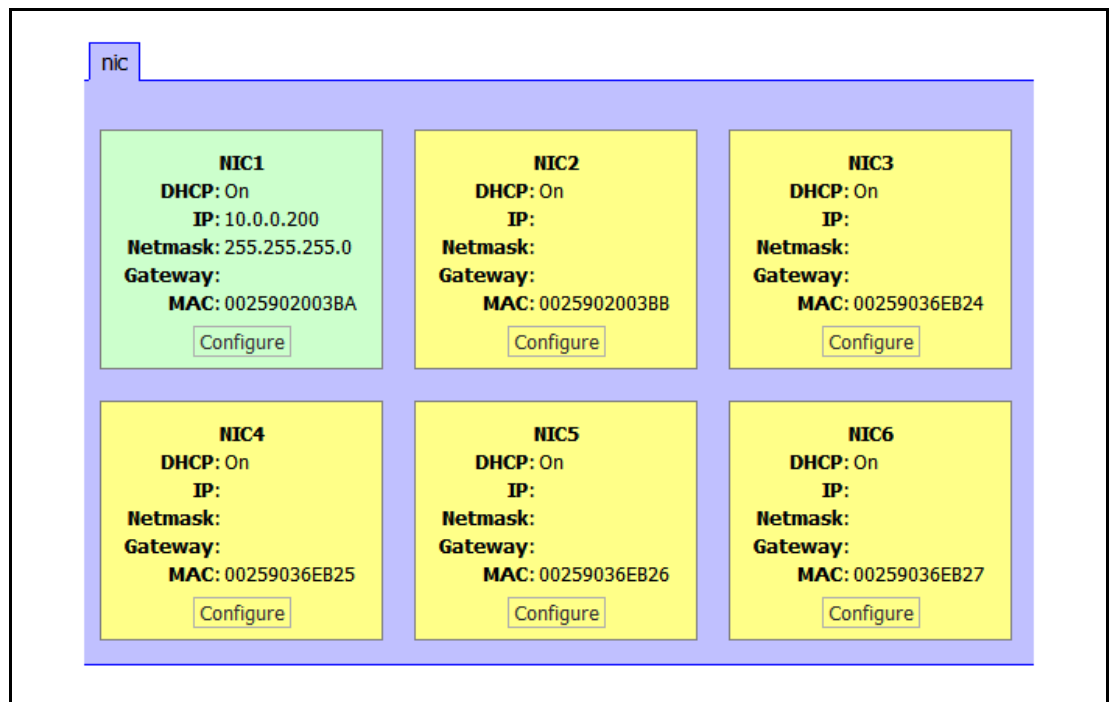

Figure E.1 NIC Configuration Tab

Ethernet interfaces provide the following configurable options:

- **DHCP** – If enabled, all other options are discarded and DHCP protocol is used to obtain IP/Netmask/Gateway.
- **IP** – A valid host IP address.
- **Netmask** – The appropriate network mask.
- **Gateway** – A single gateway IP address, for this interface only.

The **Save** button will apply the changes immediately.

Note: The network configuration process may take some time to complete, especially when DHCP is used. Please wait until the process is done. If the node is not responding use the front panel menu to restart the network or restart the node.

E.3 Advanced Tab

Advanced network configuration options are available for review and modification under the tab 'advanced'.

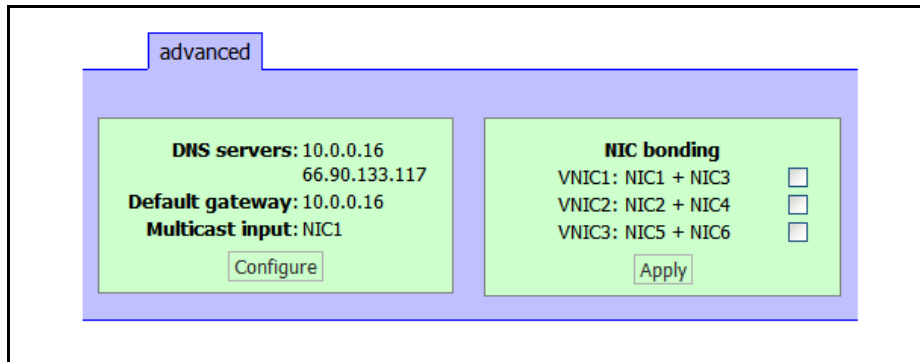

Figure E.2 Advanced Network Configuration Tab

These options are:

- **DNS servers** – A list of available DNS servers separated by comma.
- **Default gateway** – The default gateway for all interfaces.
- **Multicast input** – The NIC which will be used to capture IP multicast input.

Press **Configure** to modify any of these options.

Furthermore, when more than 2 NICs are available, the **NIC bonding** options will appear. NIC bonding allows the logical bonding of two physical NICs in order to provide high availability in network connectivity. Specifically, a pair of physical NICs is replaced by a virtual NIC (VNIC).

Note: When both Ethernet cables are removed from a bonded VNIC, for the unit to recover fully, the cables have to be replaced in a specific order (LOFI: last cable removed needs to be replaced first). Alternatively, the cables can be reconnected in any order and the network service needs to be restarted (either through the front panel or through the console).

To configure a VNIC, check the appropriate checkbox and press 'Apply'.

Note: Only one VNIC can be created each time.

You will be redirected to the 'NIC' tab where an extra NIC (VNIC1, VNIC2 or VNIC3) will be available. Press **Configure** and configure it as a regular interface.

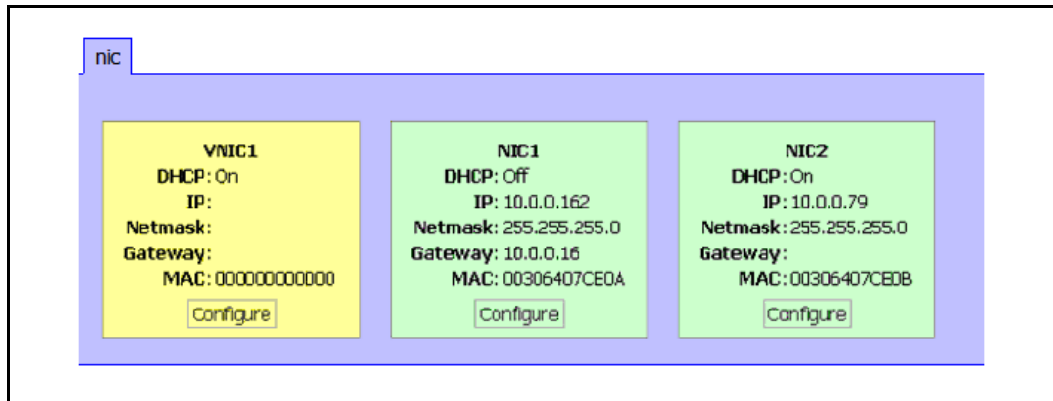

Figure E.3 NIC Tab with an Additional (Virtual) NIC

Accordingly, to decompose a VNIC and make its NICs available, uncheck its checkbox and **Apply**. You will be redirected to the 'NIC' tab where the two bonded NICs are now available for configuration.

Note: You need to configure at least one of the NICs for the decompose process to be completed. Decompose one VNIC at the time.

E.4 VLAN Tab

On the tab 'VLAN' five VLAN interfaces are available. VLAN interfaces can be configured for both Ethernet interfaces and VNICs.

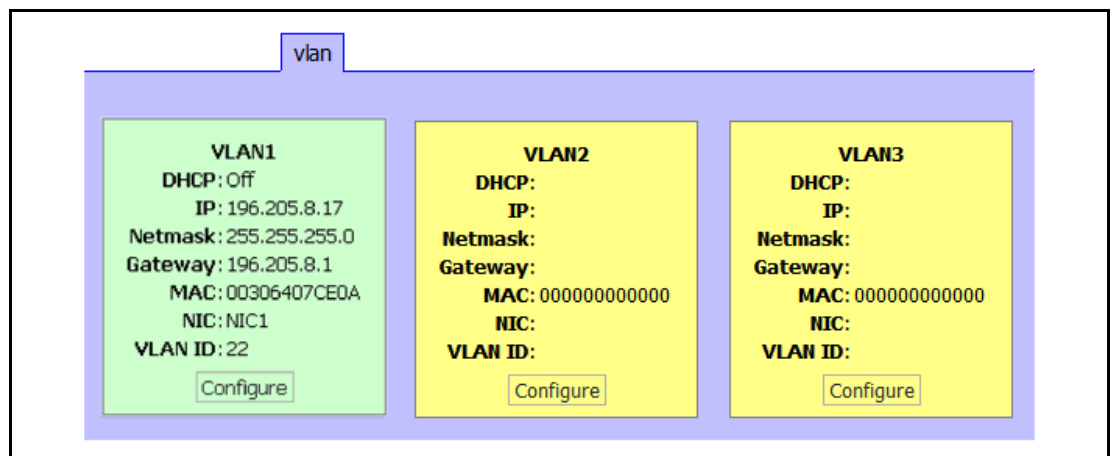

Figure E.4 Virtual LAN Configuration Tab

The VLAN configuration page adds the following options in addition to those of a simple/physical NIC:

- **NIC** – This is the Ethernet (NIC) or bonding (VNIC) interface of the VLAN.
- **VLAN ID** – This is the VLAN ID tag that uniquely identifies a VLAN. It is an integer between 2 and 4095 (inclusive).



- **Delete VLAN** – If it is checked it deletes the VLAN configuration.

Notes: Deleting a VLAN does not remove it from the tab. 5 VLANs (even those not initialized/configured) will always be shown.

Further please note the following regarding VLANs:

- Many VLANs can be assigned to a single NIC or VNIC.
- If a VLAN is assigned to a VNIC, and the VNIC is decomposed, the associated VLAN(s) will be deleted.



Aspect Ratio Adaption

Annex F

Contents

F.1	Aspect Ratio Adaption	F-3
-----	-----------------------------	-----

List of Figures

Figure F.1	Example of Case 1, 2, 3. Output Resolutions: 320x240, 352x288, 480x320	F-5
Figure F.2	Example of Case 10, 11, 12. Output Resolutions: 320x240, 480x320	F-6

List of Tables

Table F.1	Aspect Ratio Adaptation	F-3
-----------	-------------------------------	-----



BLANK

F.1 Aspect Ratio Adaption

The purpose of this Annex is to provide additional information and guidance regarding the configuration of the aspect ratio adaptation options for various types of input and output scenarios.

Table F.1 Aspect Ratio Adaptation

Case #	Source		Configuration		Internal Processing		
	Frame Size	AR	Output AR	AR Adaptation	Output : 320x240 (4:3)	Output : 352x288 (<4:3)	Output : 480x320 (>4:3)
1	SD	4x3	default	None	Resize only	Resize only	Resize only
2	SD	4x3	default	Letterbox	Resize only	Resize Padding (top/bottom)	Resize Padding (left/right)
3	SD	4x3	default	Pan & Scan	Resize only	Crop (left/right) Resize	Crop (top/bottom) Resize
4	SD	4x3	4x3	None	Resize only	Resize only	Resize only
5	SD	4x3	4x3	Letterbox	Resize only	Resize only	Resize only
6	SD	4x3	4x3	Pan & Scan	Resize only	Resize only	Resize only
7	SD	4x3	16x9	None	Resize only	Resize only	Resize only
8	SD	4x3	16x9	Letterbox	Resize Padding (left/right)	Resize Padding (left/right)	Resize Padding (left/right)
9	SD	4x3	16x9	Pan & Scan	Crop (top/bottom) Resize	Crop (top/bottom) Resize	Crop (top/bottom) Resize
10	SD	16x9	default	None	Resize only	Resize only	Resize only
11	SD	16x9	default	Letterbox	Resize Padding (top/bottom)	Resize Padding (top/bottom)	Resize Padding (top/bottom)
12	SD	16x9	default	Pan & Scan	Crop (left/right) Resize	Crop (left/right) Resize	Crop (left/right) Resize
13	SD	16x9	4x3	None	Resize only	Resize only	Resize only
14	SD	16x9	4x3	Letterbox	Resize Padding (top/bottom)	Resize Padding (top/bottom)	Resize Padding (top/bottom)
15	SD	16x9	4x3	Pan & Scan	Crop (left/right) Resize	Crop (left/right) Resize	Crop (left/right) Resize
16	SD	16x9	16x9	None	Resize only	Resize only	Resize only
17	SD	16x9	16x9	Letterbox	Resize only	Resize only	Resize only
18	SD	16x9	16x9	Pan & Scan	resize only	Resize only	Resize only
19	HD	16x9	default	None	Resize only	Resize only	Resize only
20	HD	16x9	default	Letterbox	Resize Padding (top/bottom)	Resize Padding (top/bottom)	Resize Padding (top/bottom)
21	HD	16x9	default	Pan & Scan	Crop(left/right) Resize	Crop (left/right) Resize	Crop (left/right) Resize

Case #	Source		Configuration		Internal Processing		
	Frame Size	AR	Output AR	AR Adaptation	Output : 320x240 (4:3)	Output : 352x288 (<4:3)	Output : 480x320 (>4:3)
22	HD	16x9	4x3	None	Resize only	Resize only	Resize only
23	HD	16x9	4x3	Letterbox	Resize Padding (top/bottom)	Resize Padding (top/bottom)	Resize Padding (top/bottom)
24	HD	16x9	4x3	Pan & Scan	Crop (left/right) Resize	Crop (left/right) Resize	Crop (left/right) Resize
25	HD	16x9	16x9	None	Resize only	Resize only	Resize only
26	HD	16x9	16x9	Letterbox	Resize only	Resize only	Resize only
27	HD	16x9	16x9	Pan & Scan	Resize only	Resize only	Resize only

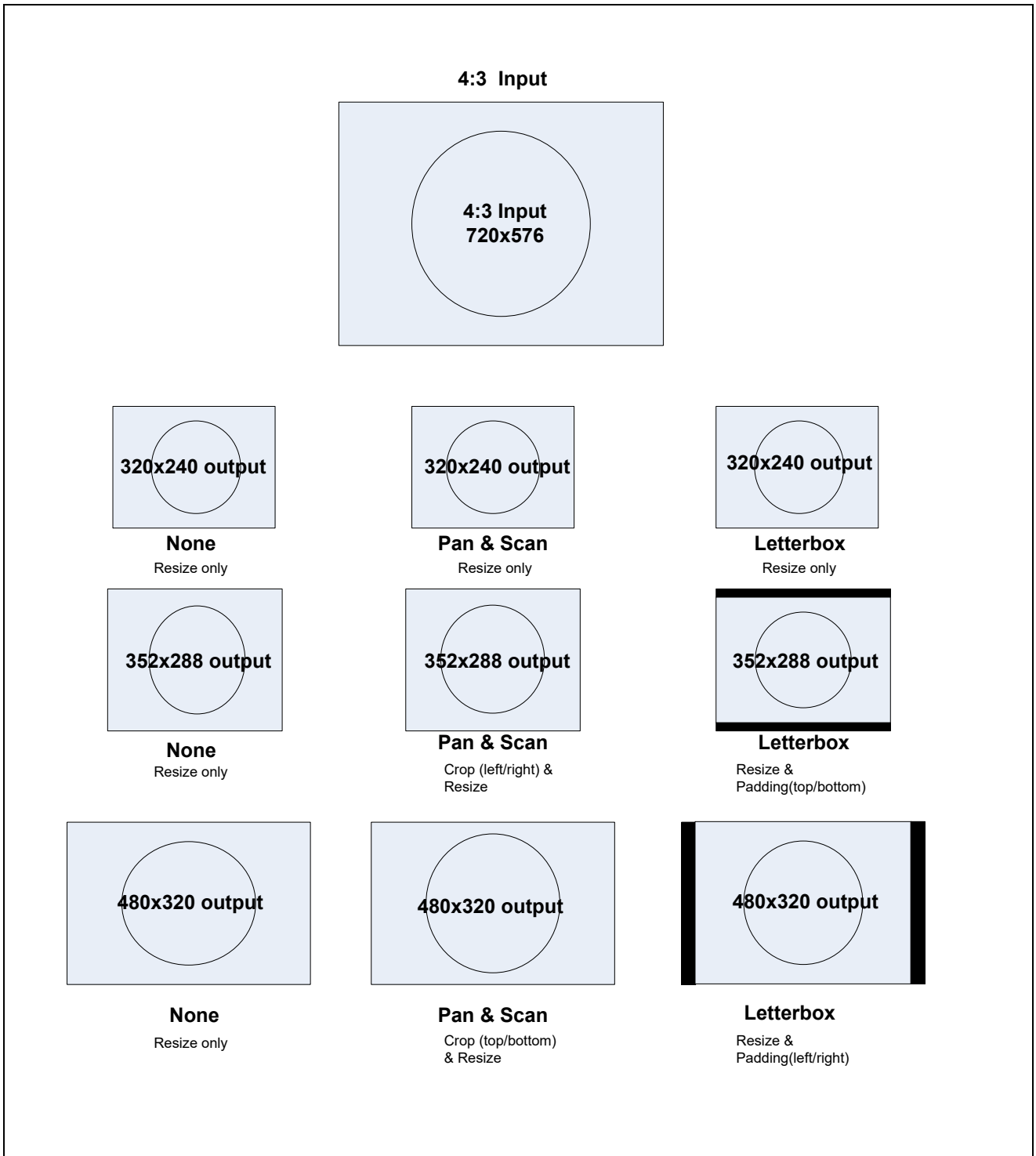

Figure F.1 Example of Case 1, 2, 3. Output Resolutions: 320x240, 352x288, 480x320

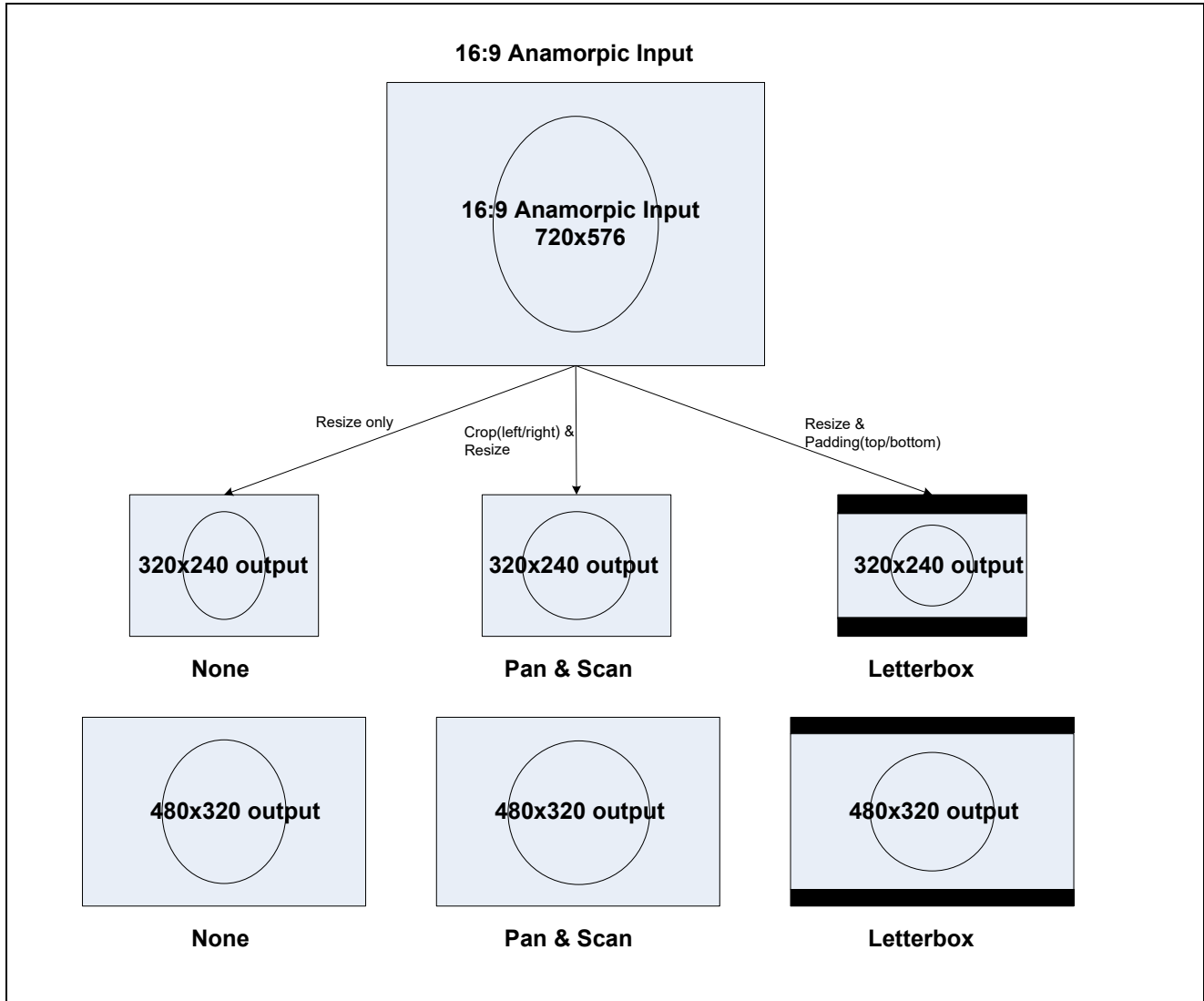

Figure F.2 Example of Case 10, 11, 12. Output Resolutions: 320x240, 480x320

BLANK

